

Dodecahedron Speaker Set

Omnidirectional Sound Source



DS3 Dodecahedron Loudspeaker



PA3 Power Amplifier



Remote control for PA3

Comprised of the DS3 Dodecahedron Loudspeaker and the PA3 Power Amplifier, the set generates a Pink noise signal with an acoustically-flat frequency response.

NOTE Always wear an appropriate ear protection when using the speaker set.



Standard Operation

1. Connect the PA3 to the DS3 with the supplied Speakon cable
2. Connect the PA3 to AC mains power and switch it on => the Signal ON button glows red ● (amplifier is muted)
3. Attach the remote control antenna to the PA3
4. Press the Signal Source button to select the required test signal => the selected Signal Source LED glows green ●
5. Press the Signal ON button, or the button on the remote control to unmute / mute the PA3 => the Signal ON button glows green ● (unmuted) / red ● (muted)
6. Adjust the DS3 volume using the output level control

Signal Source Selection

- EQ Pink Internal equalized Pink noise for acoustically-flat frequency response (→ see page 3, footnote 3)
- EQ Line Enables Line IN socket. Any external input signal is processed with the default DS3 equalization
- Preset 3 Internal Pink noise without equalization (for maximum output power from the DS3)
- Preset 4 Enables Line IN socket without equalization
- Preset 5 unused (available on request for a customized signal)

Line IN Socket

Connect an external signal generator to the PA3 with an XLR cable and select the Signal Source EQ Line or Preset 4.

Subwoofer Operation

Connect the PA3 to an active subwoofer with an XLR cable. Press the Subwoofer ON button => the Subwoofer ON button glows green ●.

Warning LEDs, Troubleshooting

| Warning LED | Issue | Root cause | Countermeasure |
|-------------|--|---|--|
| ● Protect | Amplifier output is muted | A. The output current of the amplifier is too high B. Temperature inside amplifier is too high C. The amplifier output is oscillating | A. Verify the connected cable / load. Switch OFF the amplifier for >20 sec. B. Let the amplifier cool down. Verify that the built-in fan is operating. C. Check the compatibility of the speaker (i.e. verify the load impedance). |
| ● Clip | Distorted output signal | The input signal level is too high | Reduce the Line IN signal volume |
| (none) | Amplifier audibly reduces the output volume (Note: this is a protection feature) | D. The input signal is overloading the amplifier E. The impedance of the output load is too low (i.e. output power too high) | D. Select another test signal. Reduce the Line IN signal volume. E. Verify or modify the load. Check for external short circuit. |

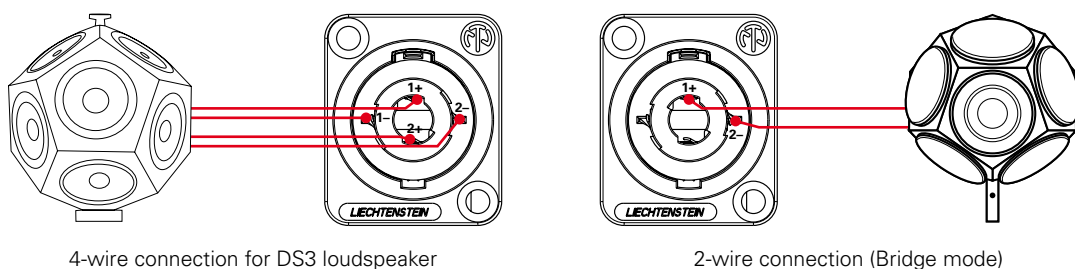
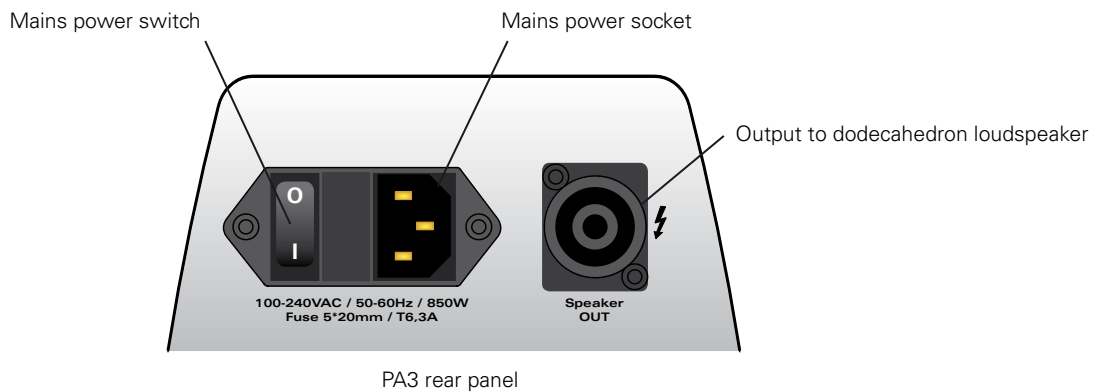
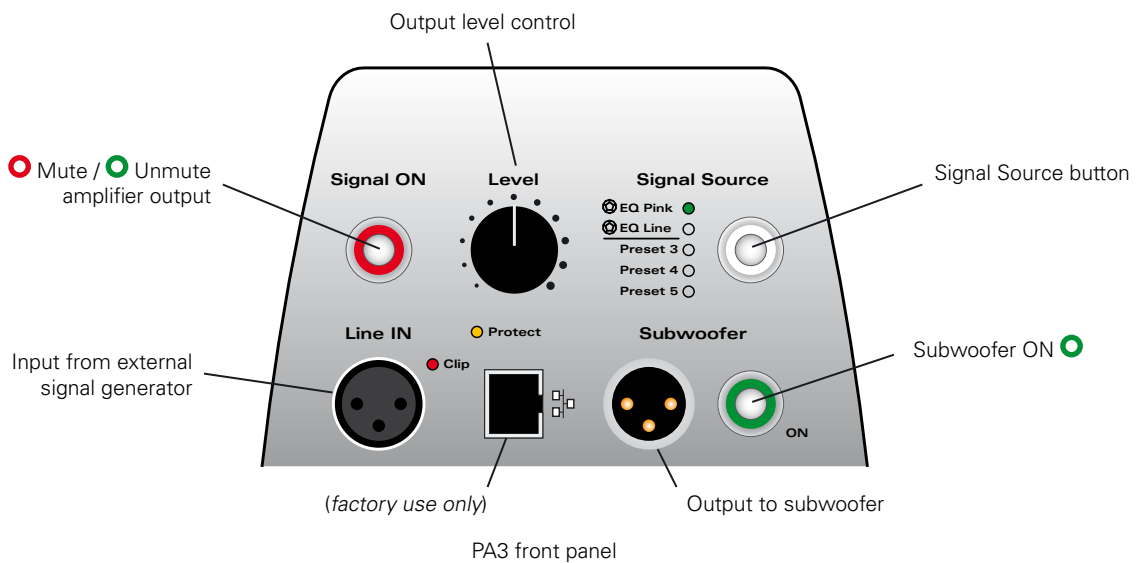

Specifications PA3

| | |
|---|--|
| Maximum short-period output power | 2*350 W into 2*3 Ω 2*260 W into 2*4 Ω (@ 1 % THD) |
| Maximum continuous output power ¹⁾ | 2*160 W into 2*3 Ω 2*120 W into 2*4 Ω (with internal Pink noise @ maximum level) |
| Load impedance | ≥ 3 Ω (4-wire connection) or ≥ 8 Ω (2-wire connection / Bridge mode) |
| Protection | Dynamic compressor, temperature, overcurrent, DC, excessive clipping |
| Output connector | 4-pin Speakon (chn1: 1+ 1- / chn2: 2+ 2- or Bridge mode: 1+ / 2-) |
| THD | typ. 0.017 % @ 2*120 W into 2*4 Ω, 1 kHz |
| Level flatness | +0 / -3.3 dB ²⁾ @ 20 Hz to 20 kHz |
| Signal-to-noise ratio | ≥ 86 dB, bandwidth 22 kHz |
| Damping factor | ≥ 120 @ load ≥ 3 Ω and f < 2 kHz |
| Voltage gain | Muted Level adjustable from -18 dB to 29.0 dB |
| Line IN Input connector Input sensitivity Maximum input level Input impedance | XLR symmetric 0 dBu for specified output power into 2*3 Ω / 2*4 Ω (max. gain) 20 dBu / ±11 Vp 10 kΩ symmetric |
| Subwoofer OUT Output connector Voltage gain Maximum output level Output impedance Filter | XLR symmetric 3 dB 18 dBu / ±8.72 Vp ≤ 600 Ω symmetric Lowpass 120 Hz Butterworth 24 dB / Octave (4 th order); additional highpass at amplifier output will be automatically activated when the subwoofer is switched ON |
| Signals (selectable) EQ Pink ³⁾ EQ Line Pink Line User | Internal noise generator, equalized Pink noise (Cf = 3.05) External signal, equalized Internal noise generator, Pink noise without equalization (Cf = 3.4) External signal, without equalization Custom specific (<i>available on request</i>) |
| Default equalization of Dodecahedron DS3 1/3 Octave 1/1 Octave | Flat acoustic frequency response from 100 Hz to 8 kHz 100 dB re 1 pW ±3 dB 105 dB re 1 pW ±3 dB |
| Warning LEDs Clip Protect | Line IN input Amplifier automatically switches the output OFF at high temperature, overcurrent etc.; with auto-retry function |
| Controls Signal ON Level Signal Source Subwoofer ON | ON/OFF switch with green/red LED Knob for gain control Switch for selection of output signal ON/OFF switch with green LED |
| Remote control | Amplifier output ON/OFF |
| Conformity | <ul style="list-style-type: none"> • EU: EMV acc. EN61326-1:2006 / harmonized standards: EN61000-4-x, EN55011:2009 • China: R&TTE standard 1999/5/EG; State Radio Regulation of China • Japan: ARIB STD-T 67 • USA: 315 MHz sender: according to FCC part 15 |
| Weight | 5 kg (11 lbs) |
| Dimensions (L x W x H) | 358 x 173 x 245 mm (14.1" x 6.8" x 9.7") |
| Mains supply | 100 to 240 VAC, 50/60 Hz, 550 W typical power consumption |
| Fuse | T6.3 A (5 x 20 mm) |
| Temperature, humidity | 0° to +50°C (32° to 122°F) @ ≤ 90% RH (non-condensing), active cooling with fan |
| Accessories (included) | <ul style="list-style-type: none"> • Remote control • Carrying bag |
| Order information NTi Audio # | 600 000 506 (433 MHz) / 600 000 510 (315 MHz, USA) / 600 000 511 (426 MHz, JP) |

¹⁾: Without filtering

²⁾: Without equalization, with 20 kHz Butterworth high pass (24 dB damping factor)

³⁾: The ISO16283-1:2014 standard requires a minimum energy-averaged sound pressure difference between contiguous 1/3rd octave bands. This difference shall not be more than 8 dB in the source room. The PA3 'EQ Pink' signal source is designed to deliver these minimum sound pressure level differences from the DS3. This is most suitable for room insulation measurements taken in accordance with the standard.

Specifications DS3

| | |
|--|---|
| Standards | ISO16283, ISO140, ISO3382, ISO354, DIN52210, ASTM-E2235/-E336/-E90 |
| Nominal impedance | 2*4.2 Ω |
| Maximum input power RMS | 320 W @ 1 hour Pink noise (Crest factor Cf = 9 dB) |
| Maximum peak power | 600 W |
| Sound power level | > 120.5 dB re 1 pW (typical 121 dB re 1 pW) |
| Power compression | < 1 dB (after 1 h continuous operation @ maximum power) |
| Equalized sound pressure level 1/3 Octave 1/1 Octave | PA3 amplifier output adjusted for acoustically equalized DS3 output signal 100 dB re 1 pW ±3 dB from 100 Hz to 8 kHz 105 dB re 1 pW ±3 dB from 125 Hz to 8 kHz |
| Bandwidth | 50 Hz to 10 kHz |
| Input connector | Speakon (chn1: 1+ 1- / chn2: 2+ 2-) |
| Number of speakers | 12 pcs. à 5", in dodecahedral configuration |
| Weight | 7.5 kg (16.53 lbs) |
| Diameter | 350 mm (13.8") |
| Accessories (included) | <ul style="list-style-type: none"> • Included: Carrying bag and Speakon cable 5 m • Optional: Speaker stand 35 mm, 130...230 cm retractable, with carrying bag (NTi# 600 000 508) • Optional: Speakon cable 10 m (NTi # 600 000 512) or 20 m (NTi # 600 000 513) |
| Order information | NTi Audio # 600 000 507 |

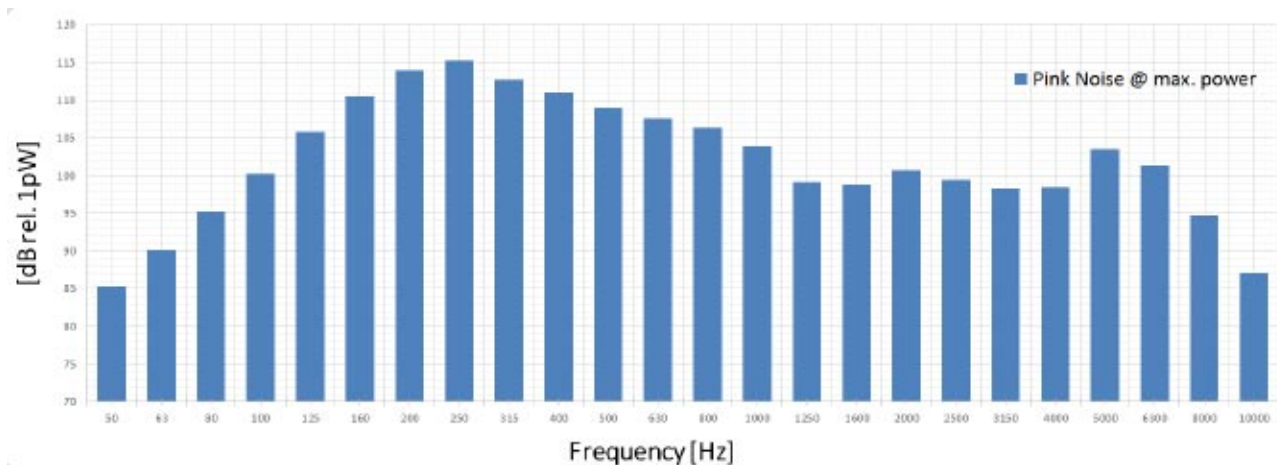

DS3 frequency response @ PA3 setting 'Pink' (maximum sound power)

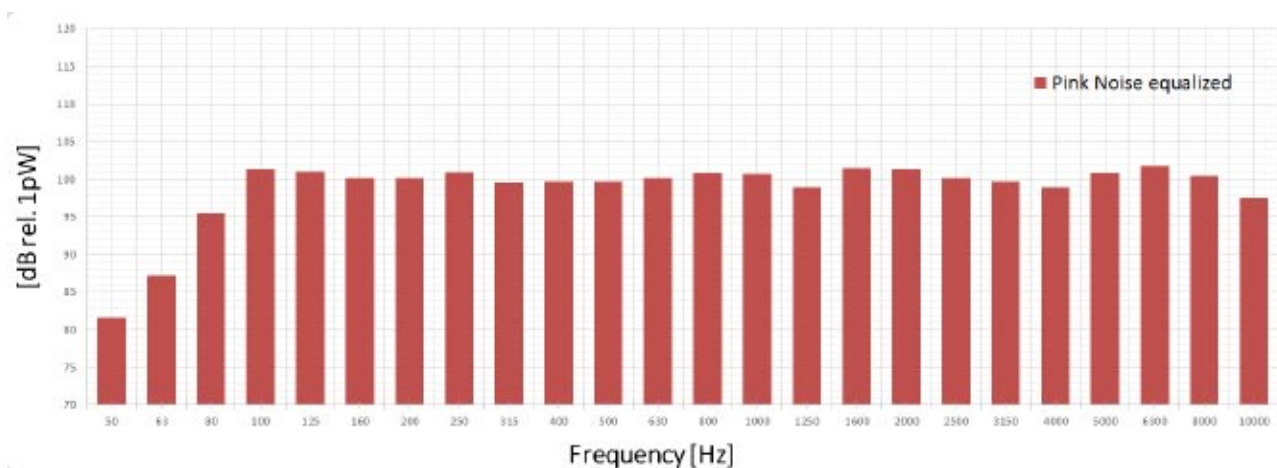

DS3 frequency response @ PA3 setting 'EQ Pink' (equalized)

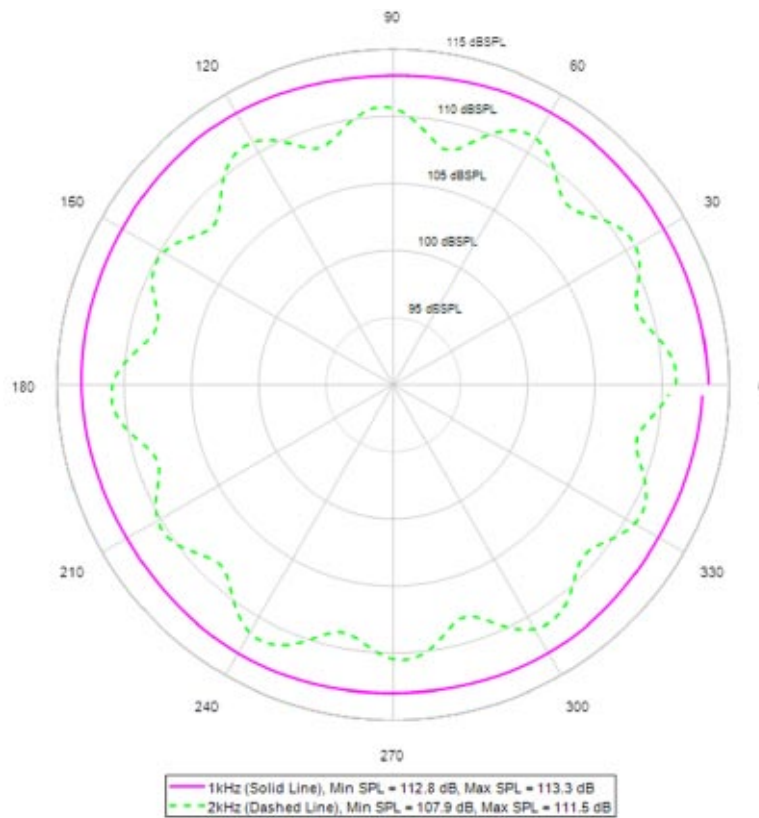

Polar plot of DS3 @ 1 kHz and 2 kHz for horizontal plane, measured in 1.5 m distance with 3rd octave analysis (signal source: GlideSweep)

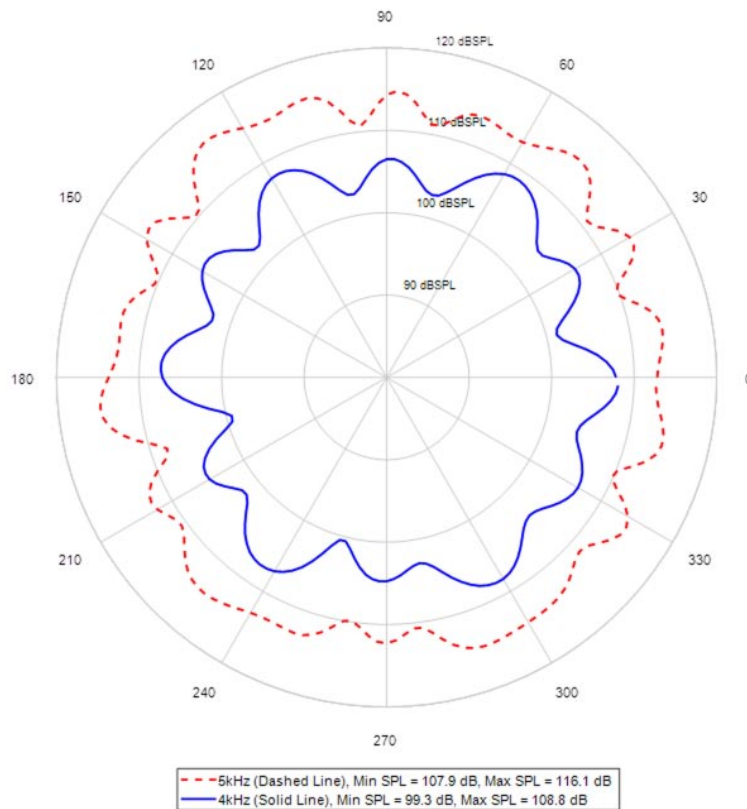

Polar plot of DS3 @ 4 kHz and 5 kHz for horizontal plane, measured in 1.5 m distance with 3rd octave analysis (signal source: GlideSweep)

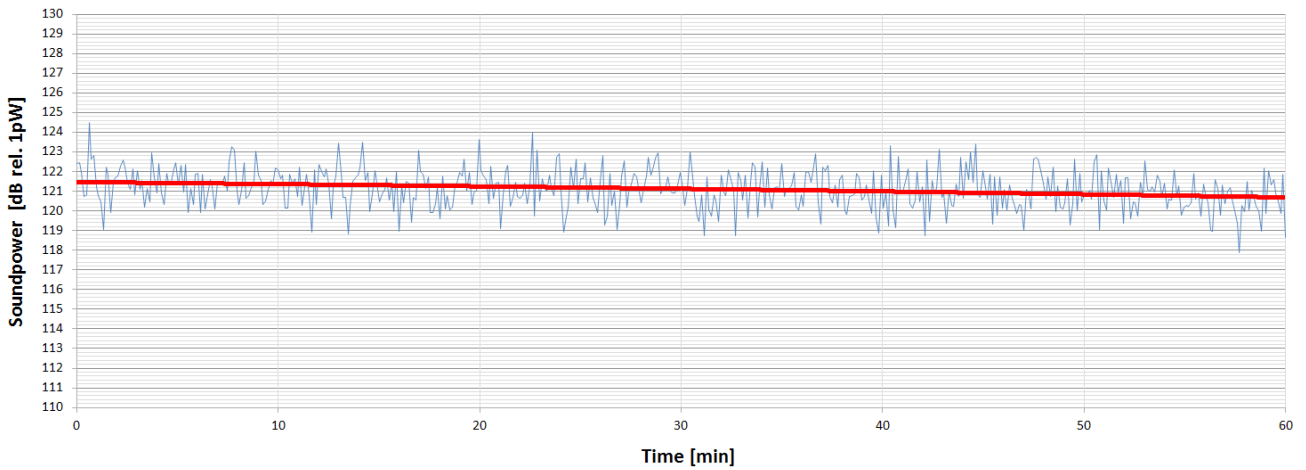

DS3 power compression @ 300 W continuous power (PA3 setting 'Pink')

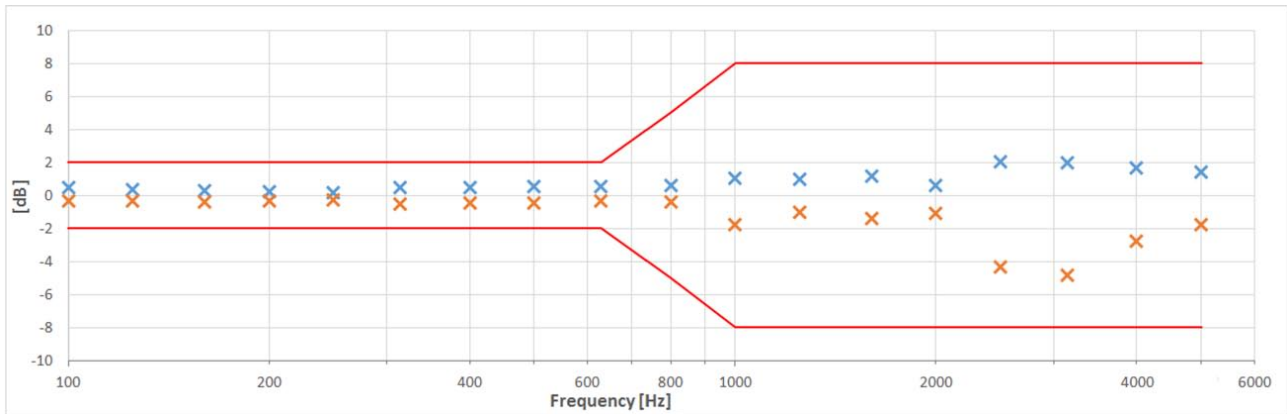

Directivity of DS3 in accordance with ISO 16283-1:2014

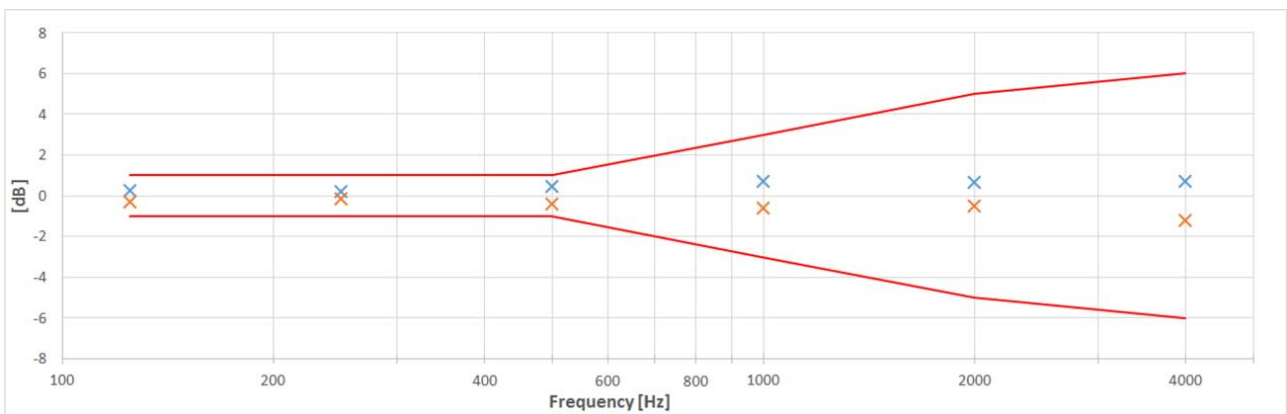

Directivity of DS3 in accordance with ISO 3382-1:2009

x: max. positive deviation from mean for moving 30° arc. average
o: max. negative deviation from mean for moving 30° arc. average

All information subject to change without notice.