

SERVICE MANUAL FOR

ADVANCE BLAST CHILLERS

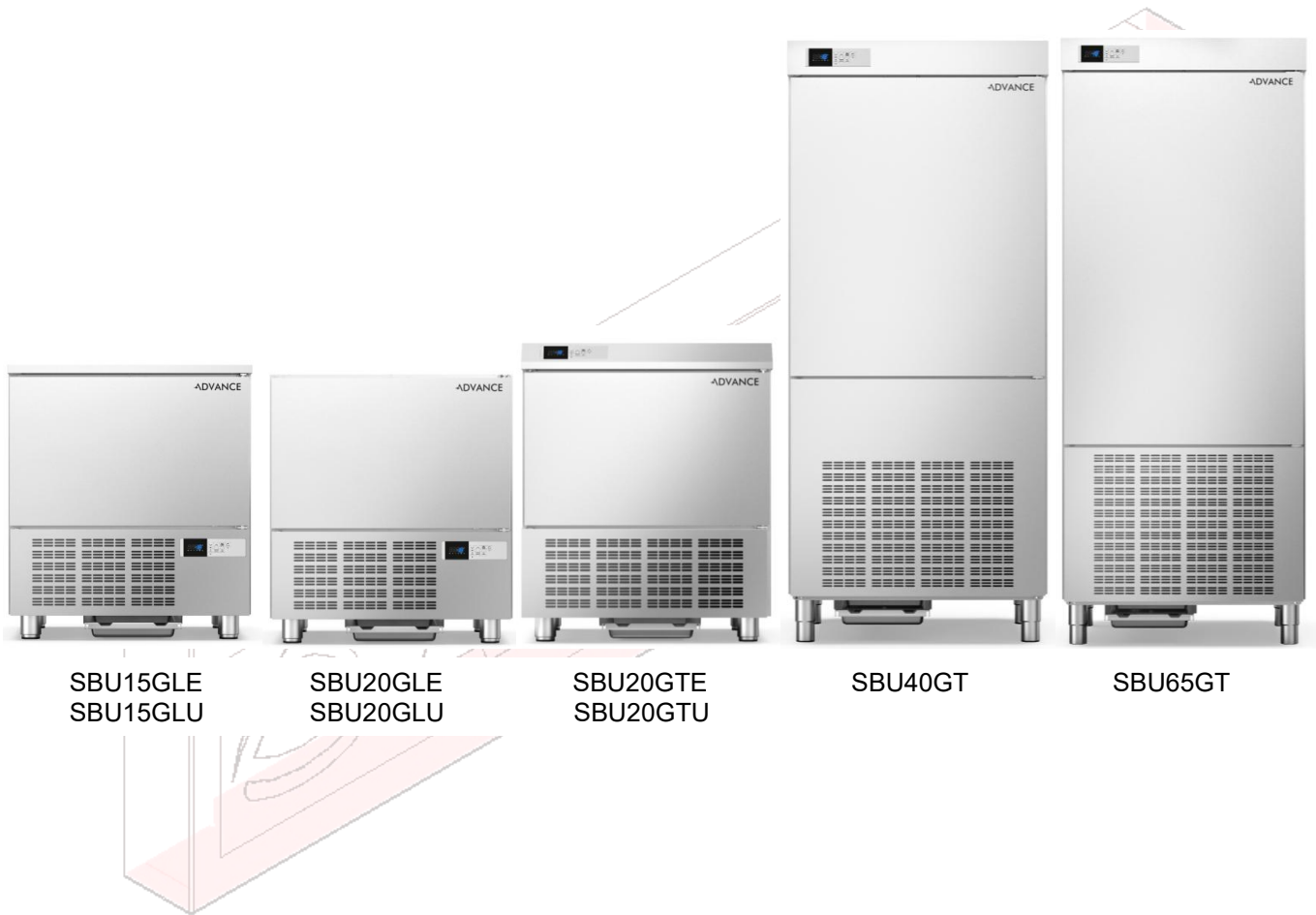



ALL THE OPERATIONS DESCRIBED IN THIS MANUAL MUST BE PERFORMED BY QUALIFIED PERSONNEL AUTHORISED TO WORK ON THE MACHINE.

THE OPERATOR MUST TAKE ALL PRECAUTIONS AND UTILISE ALL DEVICES NECESSARY FOR SAFE OPERATION.

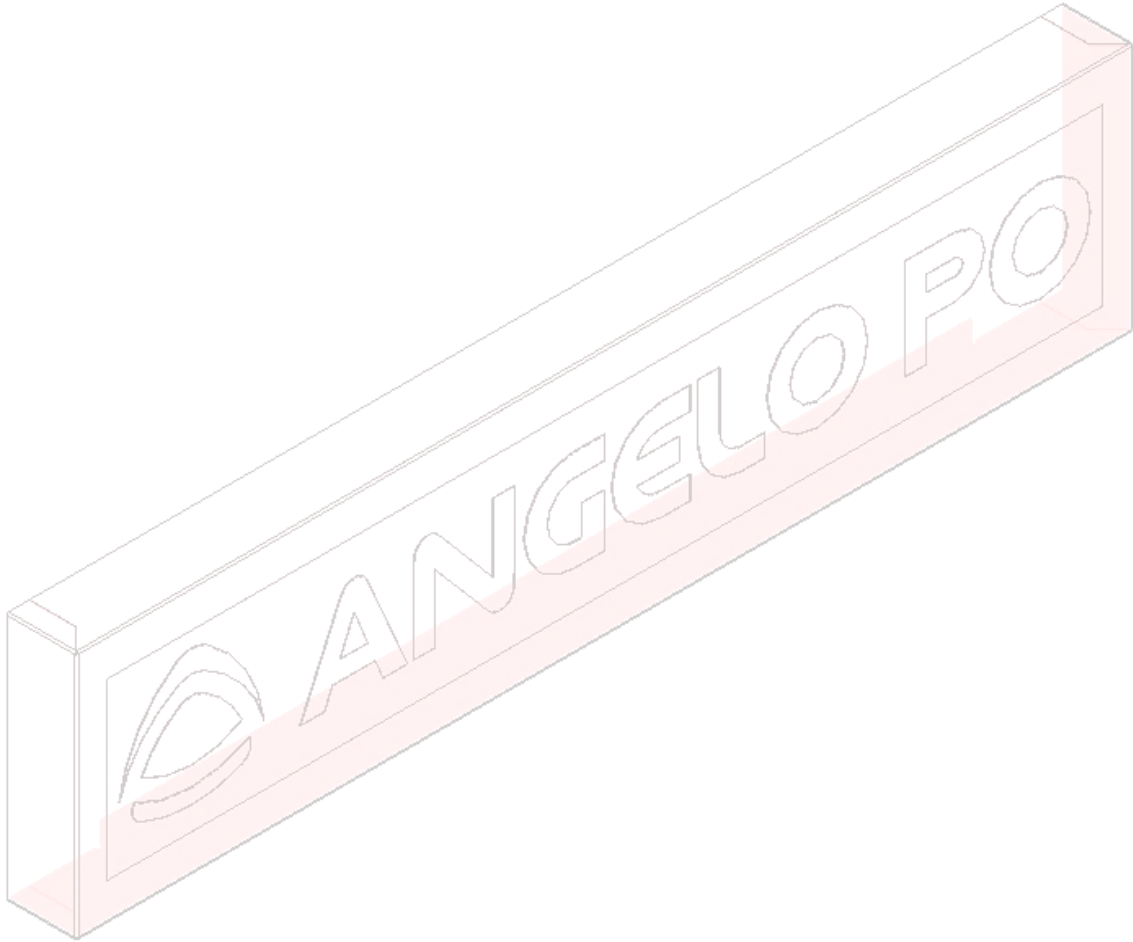

**INDEX**

	1. PRODUCT DESCRIPTION	2
	1.1 PRODUCT PHOTO	2
	1.2 TECHNICAL DATA SHEET	1
	1.3 RATING PLATE	4
	1.4 WIRING DIAGRAM	5
	2. INSTALLATION	10
	2.1. CONNECTION DIAGRAM	10
	2.2. INSTALLATION AND INSPECTIONS NOTES	18



1. PRODUCT DESCRIPTION

1.1 PRODUCT PHOTO

SBU15GL...



SBU40GT



SBU20GL...



SBU65GT



SBU20G...





1.2 TECHNICAL DATA SHEET

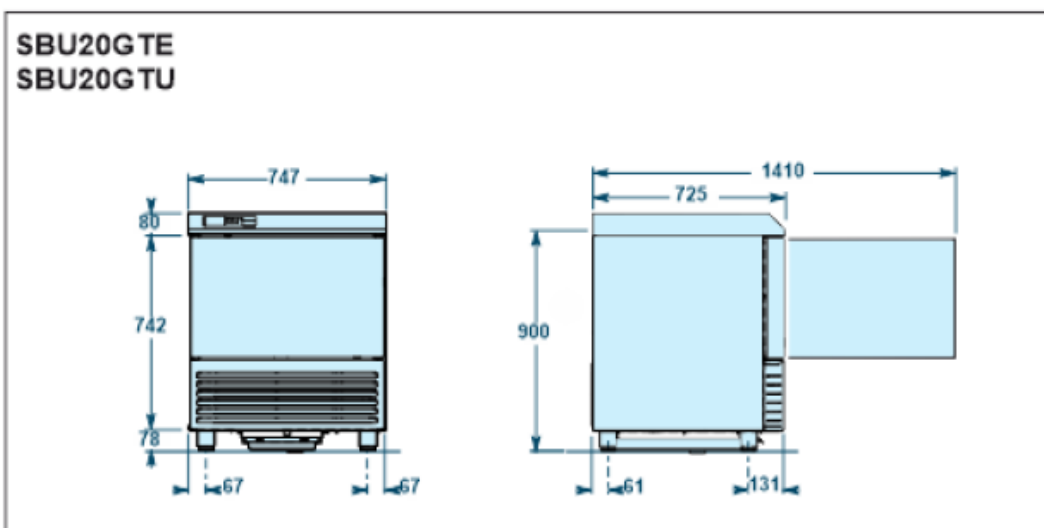
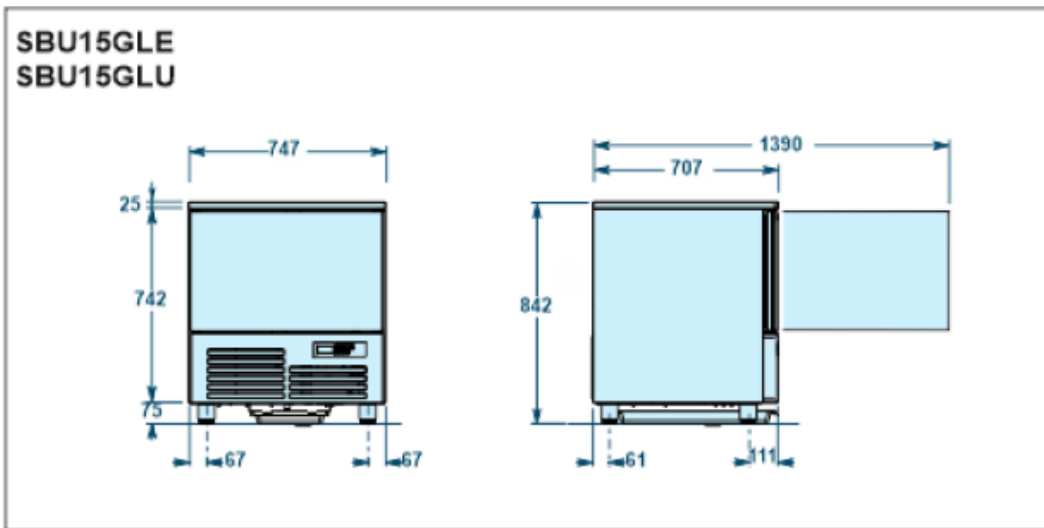
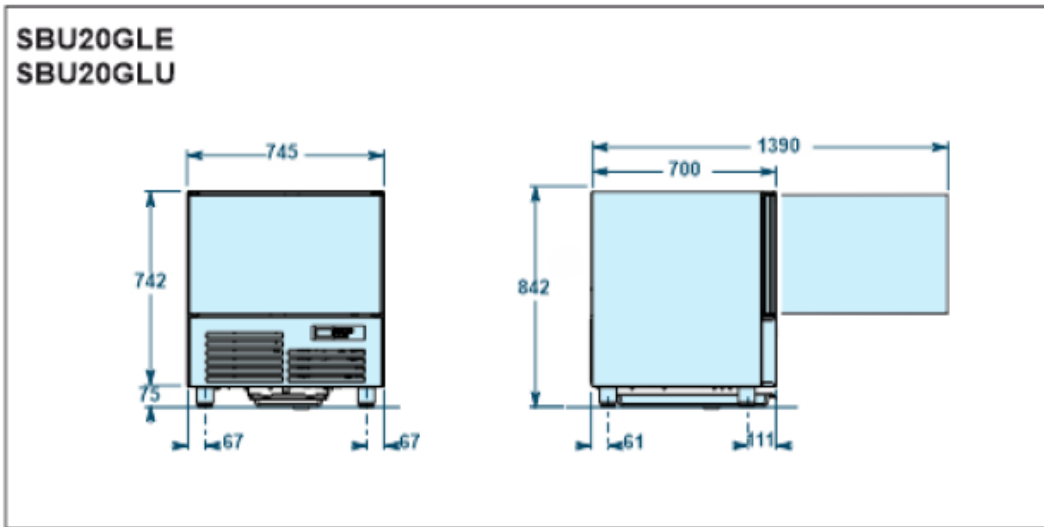

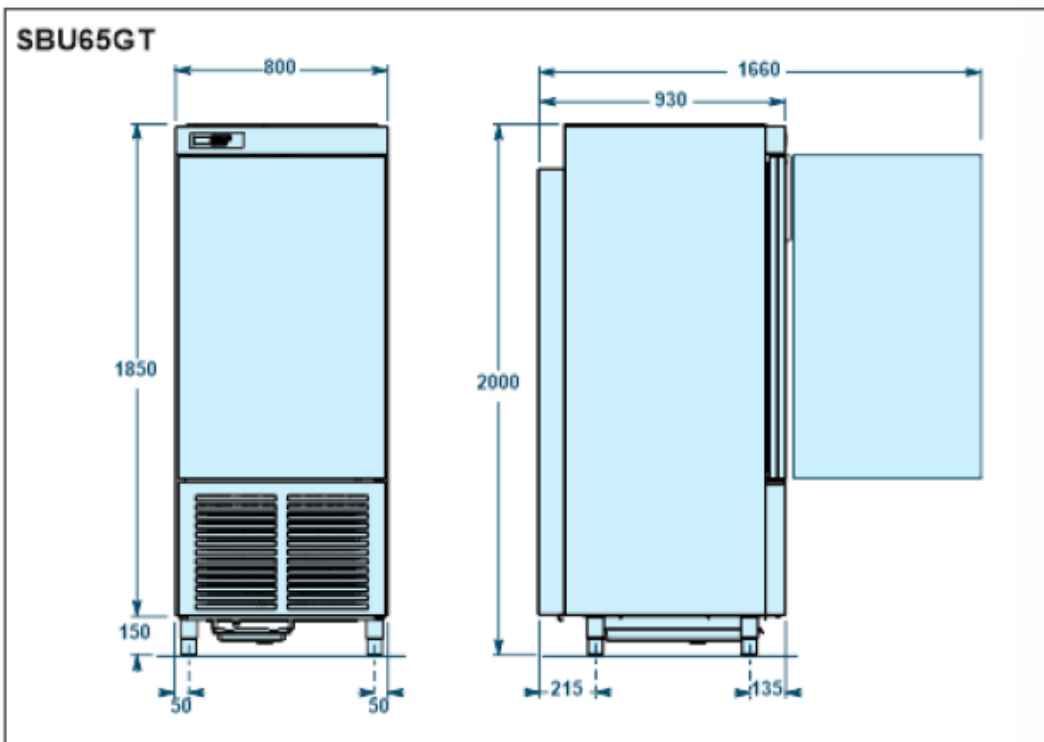
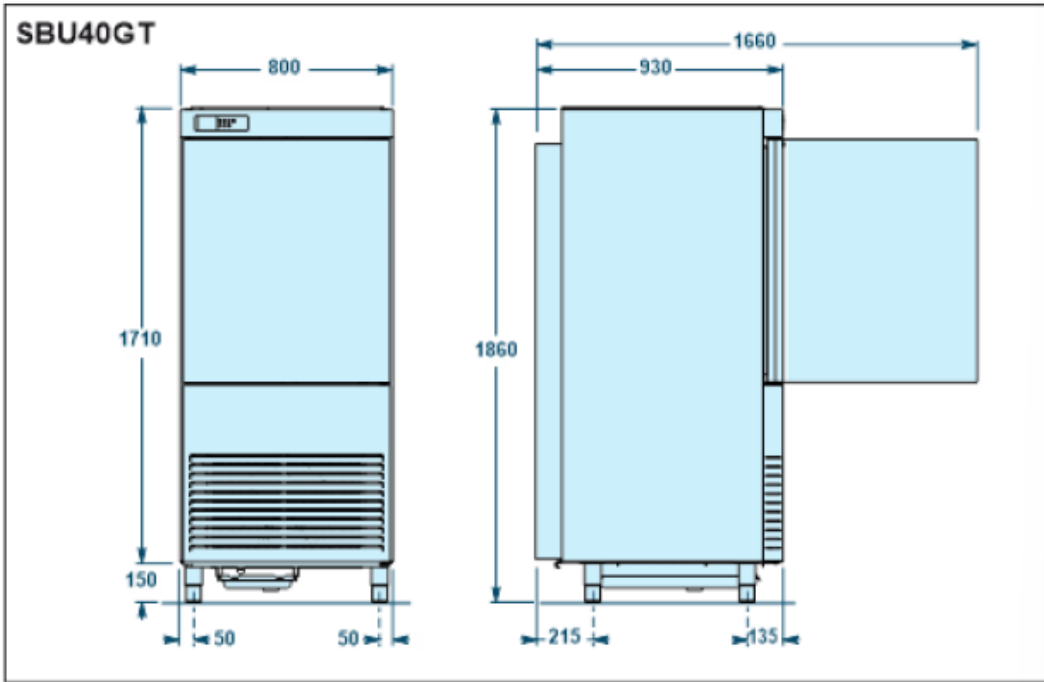



Model	SBU15GLE SBU15GLU	SBU20GLE SBU20GLU	SBU20GTE SBU20GTU	SBU40GT	SBU65GT
Gross weight	95	95	100	200	270
Net weight	85	85	90	175	245
Dimensions	747x707x842	745x700x820	747x725x900	800x930x1860	800x930x2000
Capacity					
Mass /cycle [kg] (+90°C ÷ +3°C)	18	20	20	45	70
Mass /cycle [kg] (+90°C ÷ -18°C)	10	12	12	28	38
Internal volume [l]	90	90	90	195	270
Rails	GN1/1 600x400	GN1/1 600x400	GN1/1 600x400	GN1/1 600x400	GN1/1 600x400
Trays	5	5	5	10	14/17
Power supply					
Voltage [V]	230V 1N~	230V 1N~	230V 1N~	400V 3N~	400V 3N~
Frequency [Hz]	50	50	50	50	50
Intensity [A]	3,6	3,6	3,6	4,4	5
Power input [W]	770	820	820	1900	2500
Refrigerating unit					
Refrigerating power [W]	897 (A)	897 (A)	897 (A)	935+935 (A)	1317+1317 (A)
Evaporation temperature [°C]	-23,3	-23,3	-23,3	-23,3	-23,3
Cooling temperature [°C]	+90÷+3	+90÷+3	+90÷+3	+90÷+3	+90÷+3
Cooling time [min]	90	90	90	90	90
Freezing temperature [°C]	+90÷-18	+90÷-18	+90÷-18	+90÷-18	+90÷-18
Freezing time [min]	240	240	240	240	240
Condensation temperature [°C]	+54,5	+54,5	+54,5	+54,5	+54,5
Max room temperature [°C]	+32	+32	+32	+32	+32
Compressor type	Ermetic	Ermetic	Ermetic	Ermetic	Ermetic
Coolant	R290	R290	R290	R290	R290
Coolant qty [g]	70	80	80	150+150	150+150
Condesation air	Air	Air	Air	Air	Air
Noise [dB] (A)	60	60	60	64	64
Sonda monopoint NTC	•	•	•	•	•

- (A) – Ashrae conditions
- (B) – Cecomaf conditions

1.3 RATING PLATE

Make sure that plate details and technical specifications of the power line correspond (V, kW, Hz, number of phases and power available from the mains).

When communicating with the manufacturer always quote the machine serial number, referring to its technical rating plate.

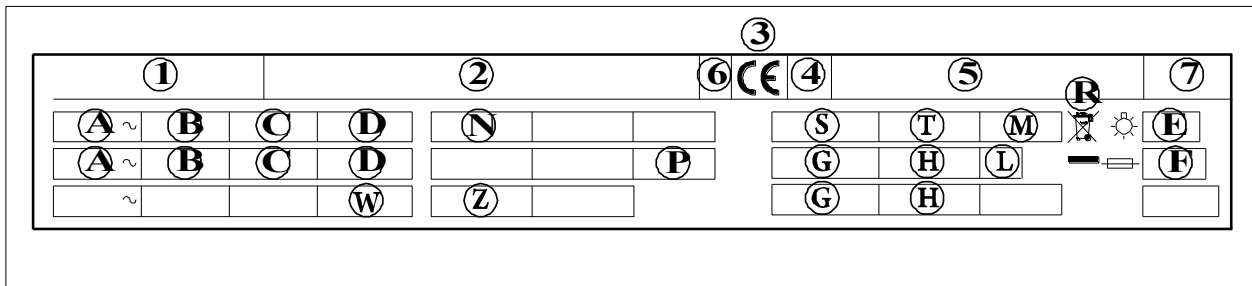

List of data contained on the rating plate:

- | | |
|---|--------------------------------|
| 1) Model | I) Defrosting resistance power |
| 2) Manufacturer and corresponding address | L) Condenser fan |
| 3) Insulation class | M) Condenser fan FLA |
| 4) Year of manufacture | N) Expansion fluid |
| 5) Serial number | O) Coolant name |
| 6) Electrical device casing protection rating | P) Quantity of coolant |
| A) Power supply voltage | Q) Climate class |
| B) Electric current intensity | R) Fuse |
| C) Frequency | S) MCA |
| D) Number of phases | T) Evaporator fan |
| E) Compressor | U) Evaporator fan FLA |
| F) Compressor RLA | V) Design pressure |
| G) Compressor LRA | W) Maximum pressure |
| H) Defrosting resistance | Z) Minimum pressure |



1.4 WIRING DIAGRAM

SBU15GL...

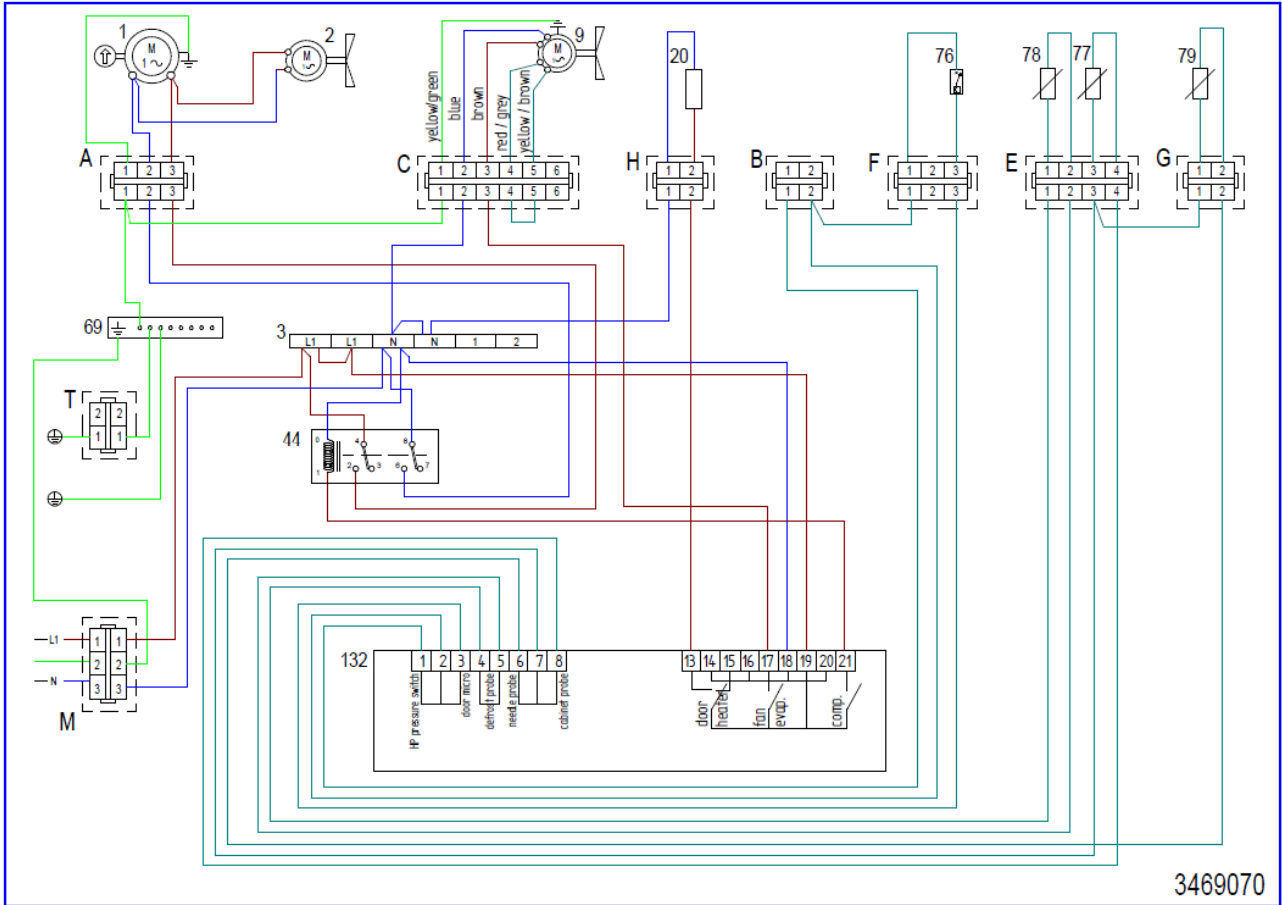



SBU20GL...

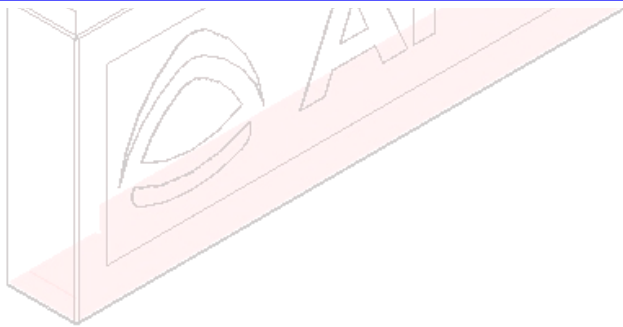
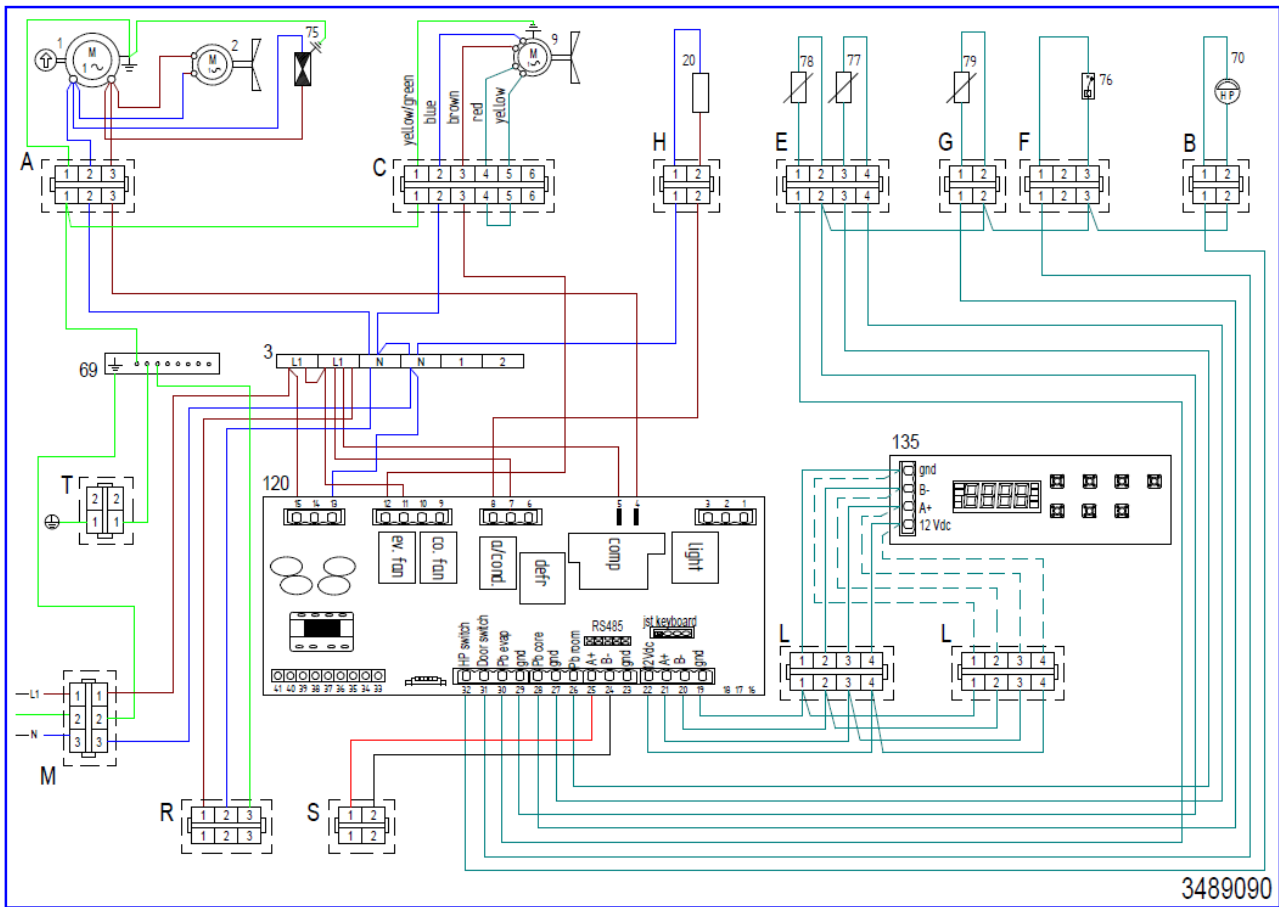



SBU20GT...

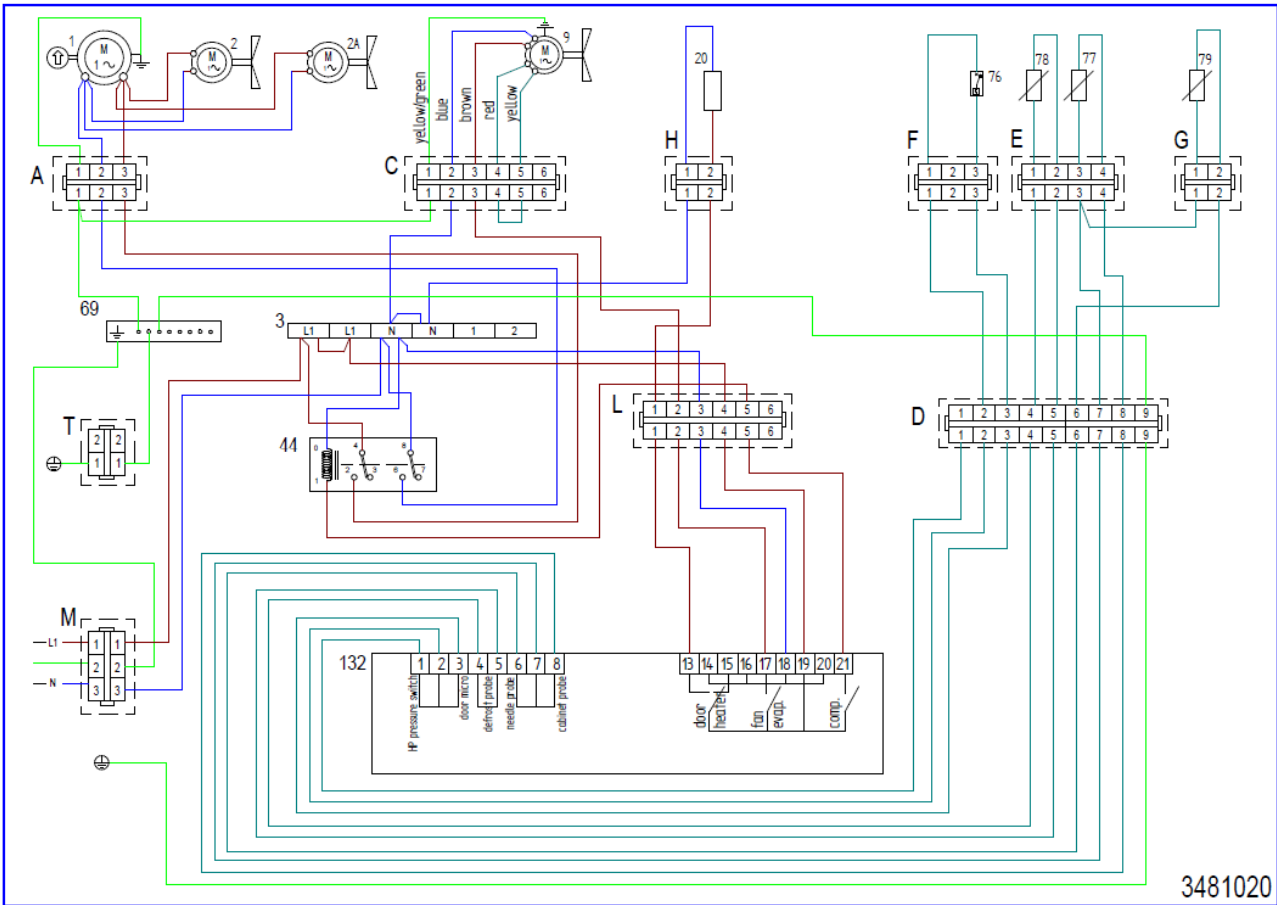

3481020

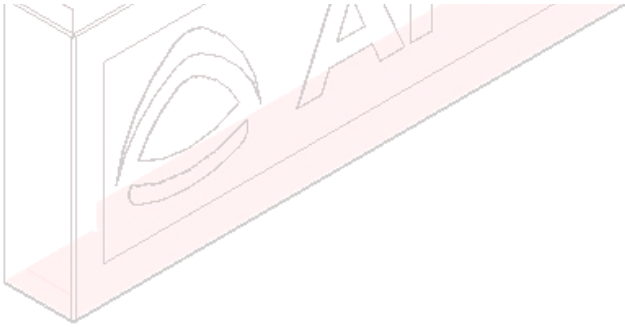



SBU65GT

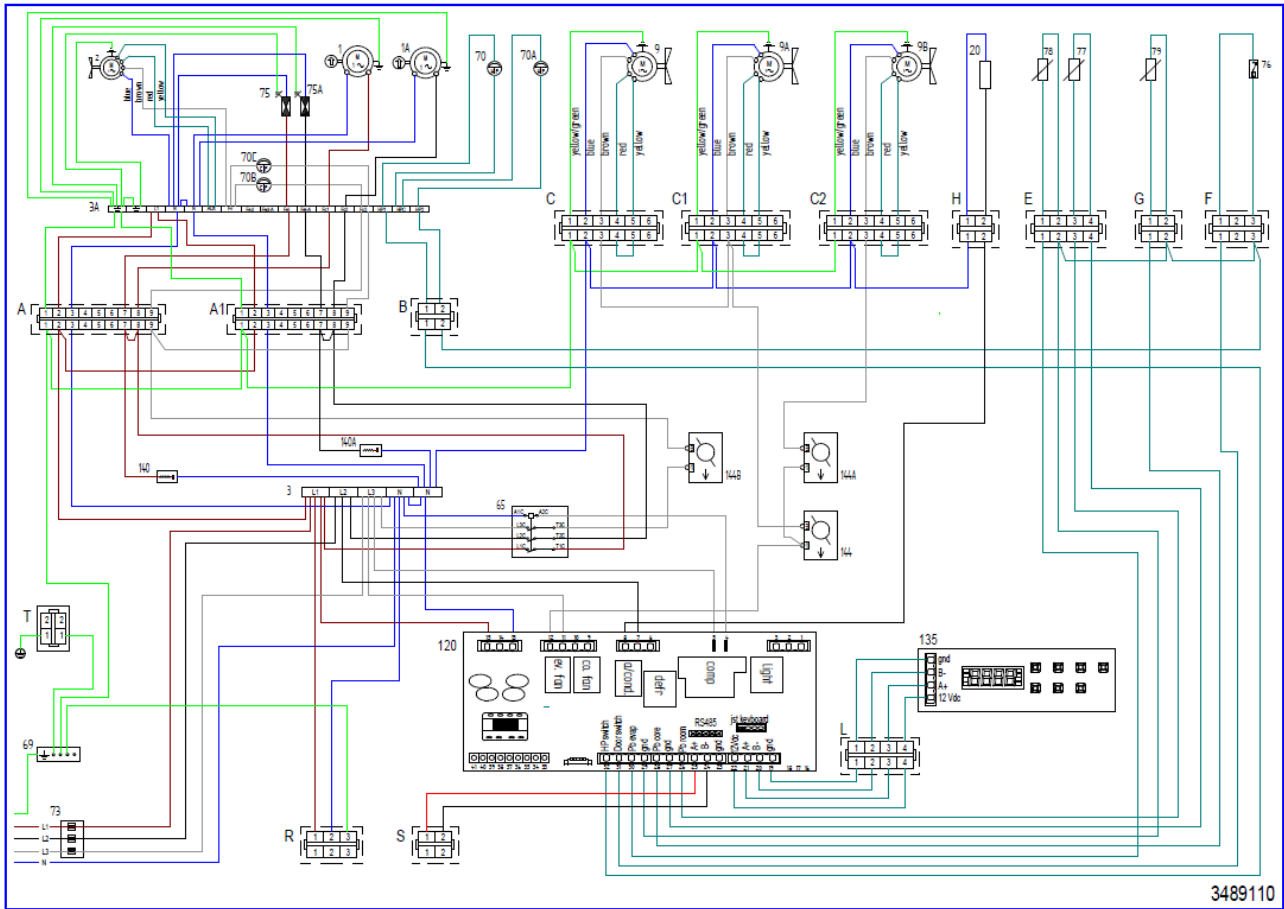

3489110

N°	DESCRIPTION	N°	DESCRIPTION
1	COMPRESSOR	73	FUSE-HOLDER WITH UNIPOLAR FUSE
1A	COMPRESSOR	75	ELECTROVALVE
2	CONDENSER FAN	75A	ELECTROVALVE
2A	THERMOSTATED CONDENSER FAN	76	MAGNETIC MICRO-SVSWITCH
3	GENERAL TERMINAL BOARD	77	COMPARTMENT PROBE
3A	GENERAL TERMINAL BOARD	78	EVAP./DEFROST PROBE
3B	GENERAL TERMINAL BOARD	79	NEEDLE CORE PROBE
9	EVAPORATOR FUN	79A	MULTIPOINT NEEDLE CORE PROBE
9A	EVAPORATOR FUN	79B	MULTIPOINT PROBE RESISTANCE
9B	EVAPORATOR FUN	80	PTC RESISTANCE FOR COMPRESSOR CASING
20	DOOR ANTICONDENSING RESISTOR	86	CONDENSER PROBE
21	DEFROST RESISTANCE	87	LCD QUICK COOLER CARD
21A	DEFROST RESISTANCE	97A	EVAP. FAN CHOKE MODULE
25	TRANSFORMER	102	BIMETALLIC SAFETY THERMOSTAT
44	RELAY COMPRESSOR	120	ELECTRICAL BOX MOTHERBOARD
65	CONTACTOR	122	LED LAMPS
66	THERMAL RELAY	127	RGB CONTROLLER
67	EVAPORATOR FAN RUN CAPACITOR	128	USB ADAPTER
67A	EVAPORATOR FAN RUN CAPACITOR	129	ENCODER ADAPTER
69	GROUNDING TERMINAL	132	LED DISPLAY ELECTRONIC BOARD
70	HIGH PRESSURE PRESSOSTAT	135	USER INTERFACE WITH LED DISPLAY
70A	HIGH PRESSURE PRESSOSTAT	140	LIQUID SOLENOID VALVE EMI FILTER
70B	CONDENSATION PRESSURE SWITCH	140A	LIQUID SOLENOID VALVE EMI FILTER
70C	CONDENSATION PRESSURE SWITCH	144	INDUCTIVE FAN FILTER (CHOKE)
71	POWER PANEL ELECTRONIC CARD	144A	INDUCTIVE FAN FILTER (CHOKE)
72	ELECTRONIC DATA CARD LCD		



2. INSTALLATION

2.1. CONNECTION DIAGRAM

SBU15GLE

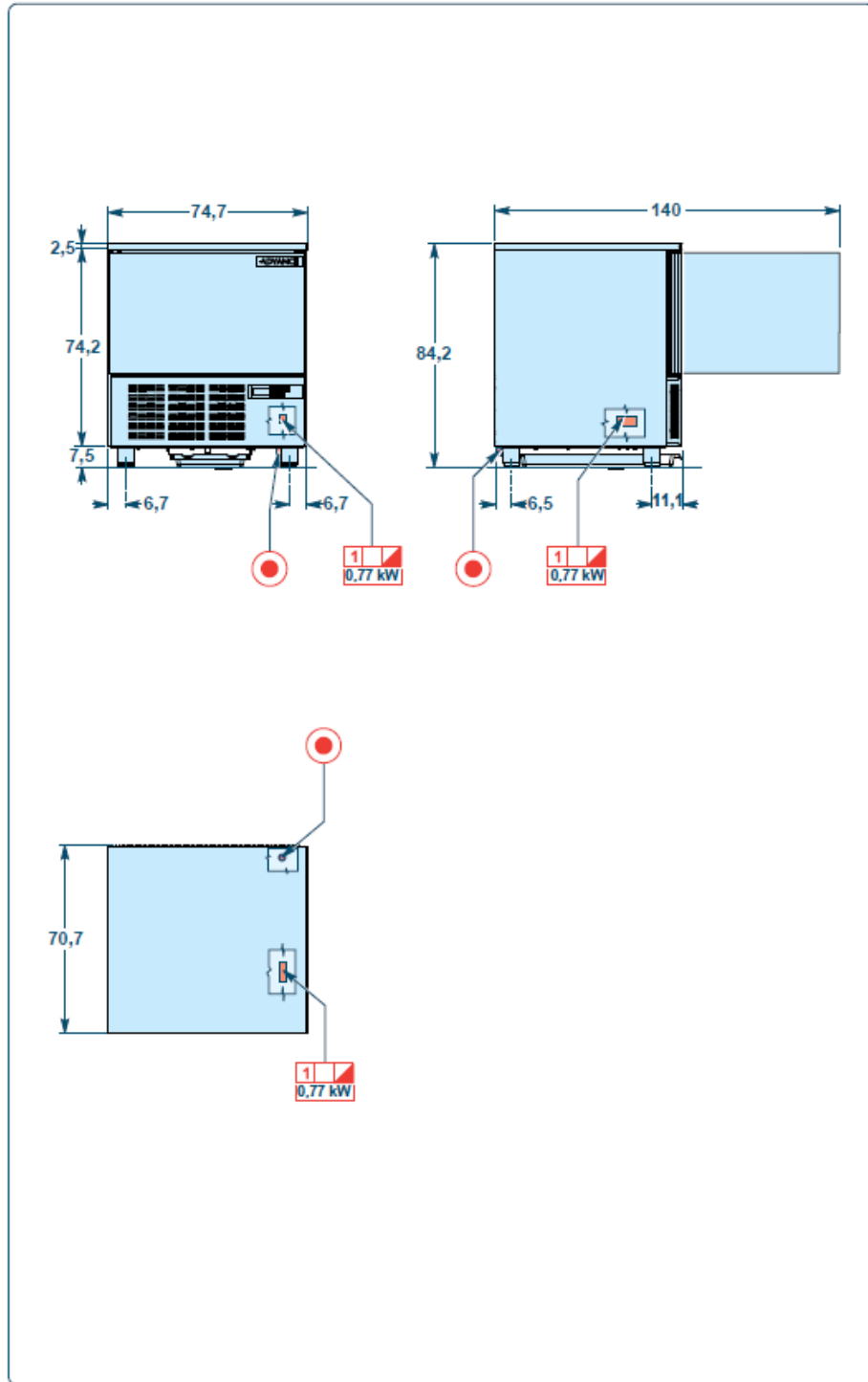

Allacciamento elettrico
 Electric connection
 Branchement électrique
 Elektroanschluss
 Conexión eléctrica

Morsettiera
 Terminal board
 Plaque à bornes
 Klemmbrett
 Tablero de bornes

Progetto - Lay Out - Projet - Entwurf - Proyecto	Area - Area - Area - Zone - Area	Posizione - Item - Position - Position - Posición
Offerta - Offer - Offre - Angebot - Oferta	Area - Area - Area - Zone - Area	Posizione - Item - Position - Position - Posición



SBU15GLU

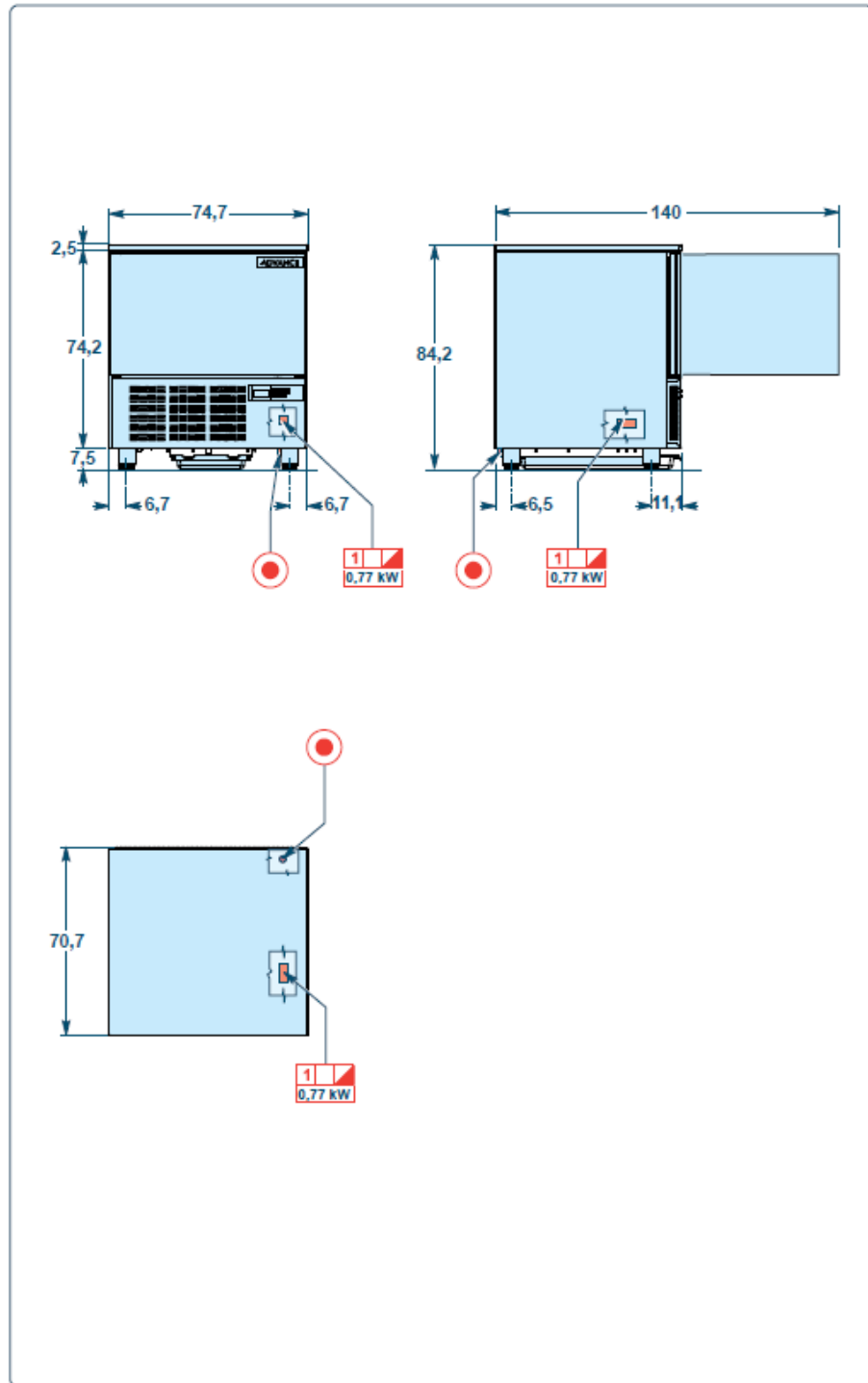

- 
 Allacciamento elettrico
 Electric connection
 Branchement électrique
 Elektroanschluss
 Conexión eléctrica
- 
 Morsetiera
 Terminal board
 Plaque à bornes
 Klemmbrett
 Tablero de bornes

Progetto - Lay Out - Projet - Entwurf - Proyecto	Area - Area - Area - Zone - Area	Posizione - Item - Position - Position - Posición
Offerta - Offer - Offre - Angebot - Oferta	Area - Area - Area - Zone - Area	Posizione - Item - Position - Position - Posición



SBU20GLE

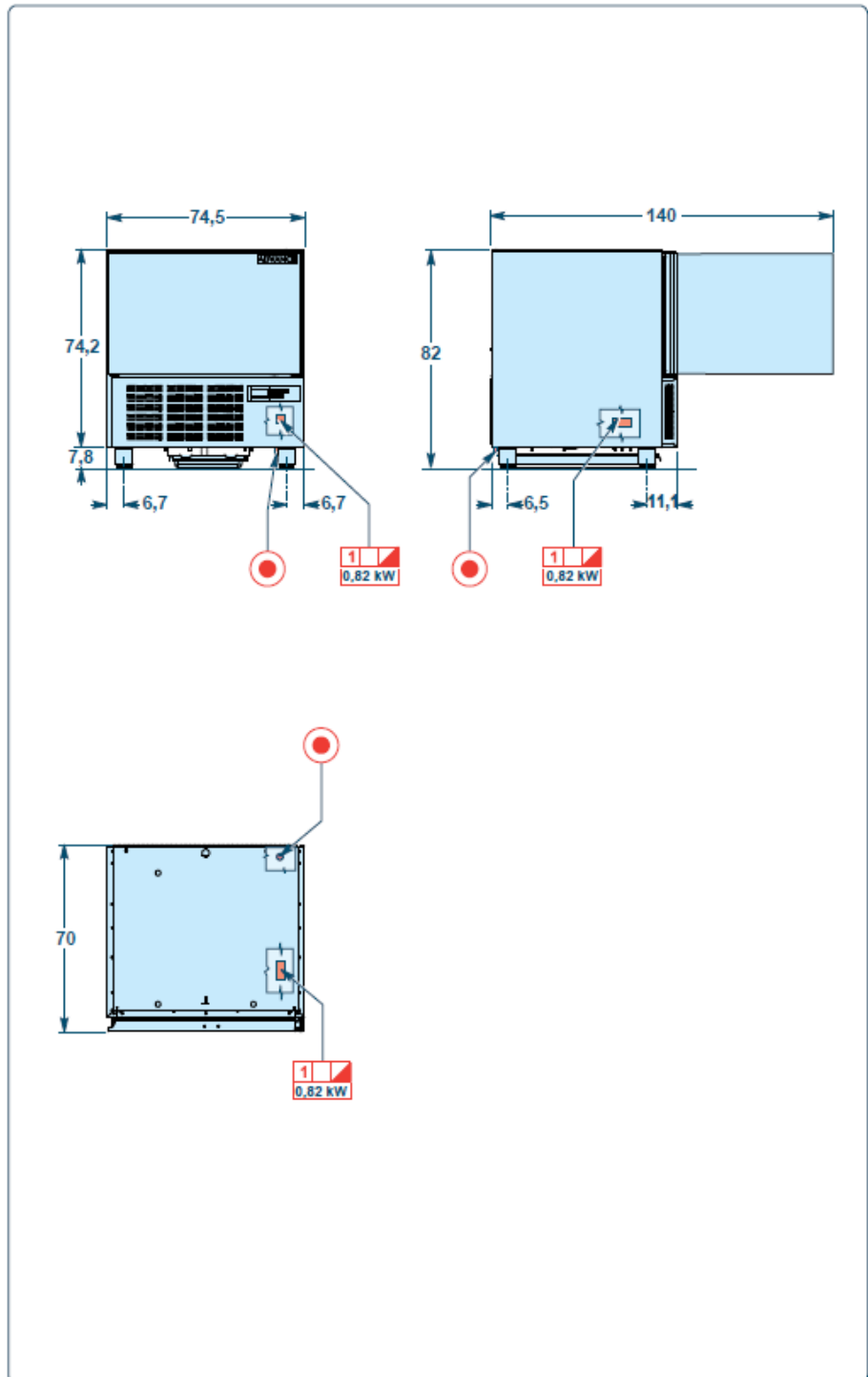

- Allacciamento elettrico
 Electric connection
 Branchement électrique
 Elektroanschluss
 Conexión eléctrica

- Morsettiera
 Terminal board
 Plaque à bornes
 Klemmbrett
 Tablero de bornes

Progetto - Lay Out - Projet - Entwurf - Proyecto	Area - Area - Area - Zone - Area	Posizione - Item - Position - Position - Posición
Offerta - Offer - Offre - Angebot - Oferta	Area - Area - Area - Zone - Area	Posizione - Item - Position - Position - Posición



SBU20GLU

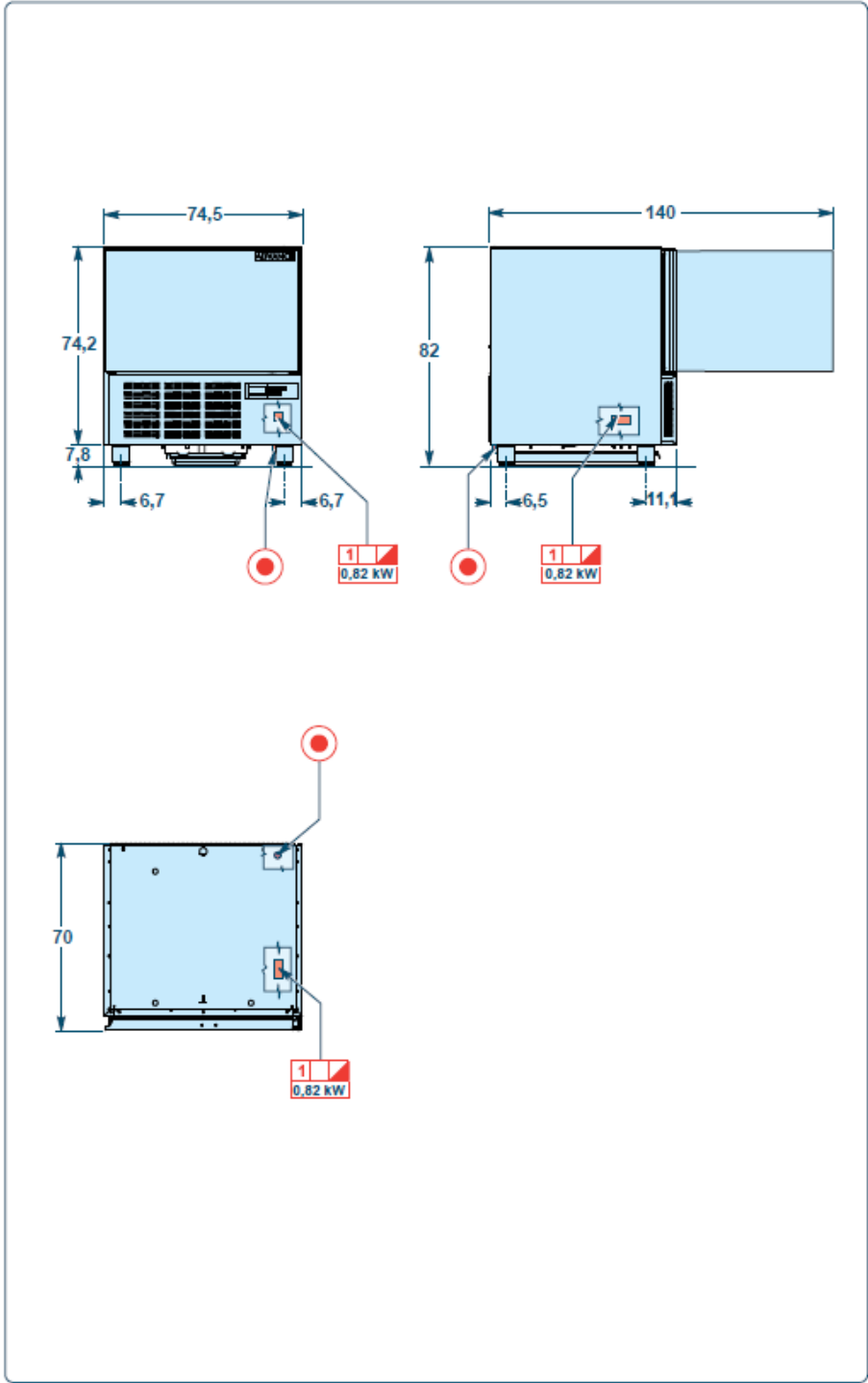

- Allacciamento elettrico
 Electric connection
 Branchement électrique
 Elektroanschluss
 Conexión eléctrica

- Morsetiera
 Terminal board
 Plaque à bornes
 Klemmbrett
 Tablero de bornes

Progetto - Lay Out - Projet - Entwurf - Proyecto	Area - Area - Area - Zone - Area	Posizione - Item - Position - Position - Posición
Offerta - Offer - Offre - Angebot - Oferta	Area - Area - Area - Zone - Area	Posizione - Item - Position - Position - Posición



SBU20GTE

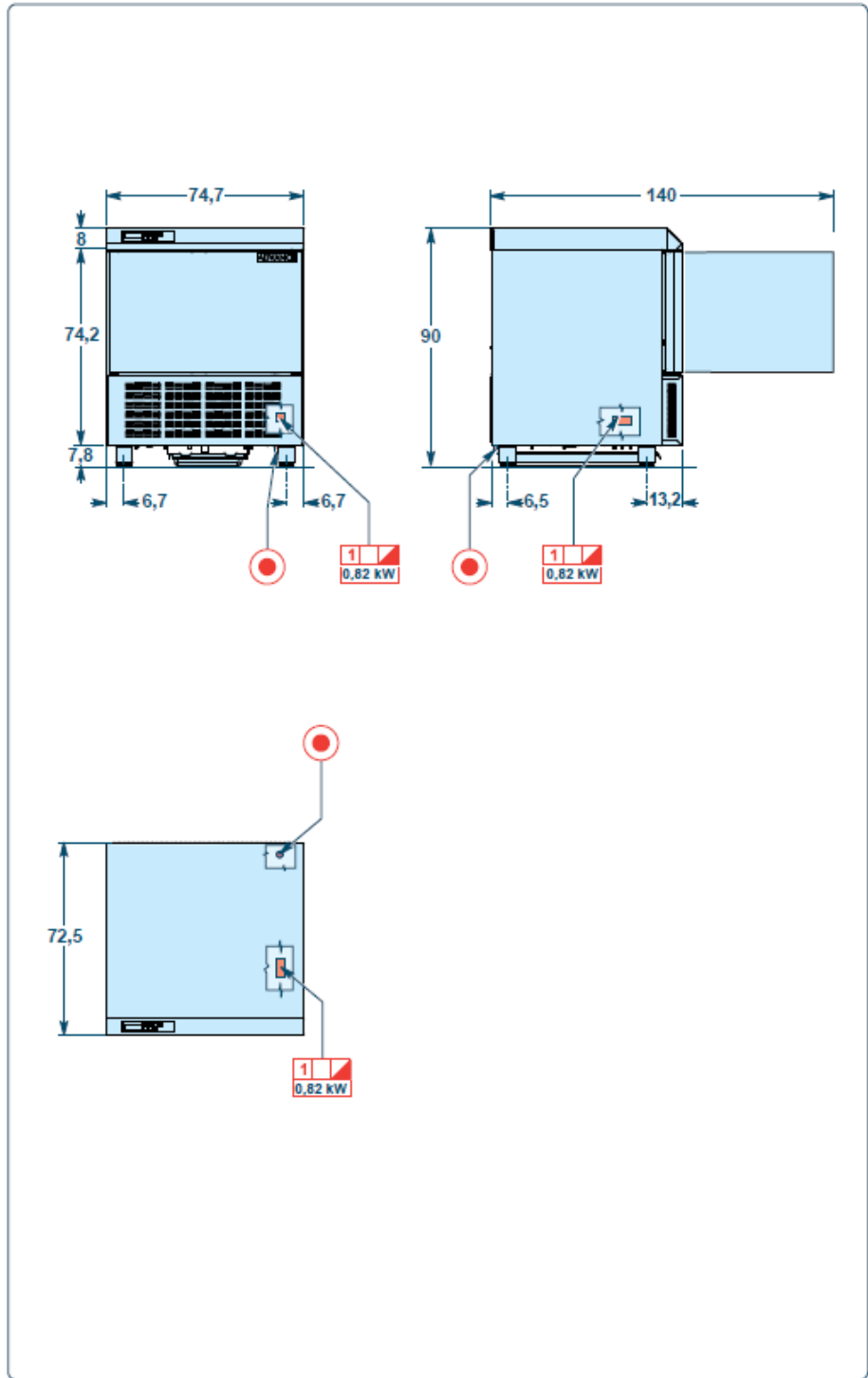



 Allacjolamento elettrico
 Electric connection
 Branchement électrique
 Elektroanschluss
 Conexión eléctrica



 Morsettiera
 Terminal board
 Plaque à bornes
 Klemmbrett
 Tablero de bornes

Progetto - Lay Out - Projet - Entwurf - Proyecto	Area - Area - Area - Zone - Area	Posizione - Item - Position - Position - Posición
Offerla - Offer - Offre - Angebot - Oferta	Area - Area - Area - Zone - Area	Posizione - Item - Position - Position - Posición

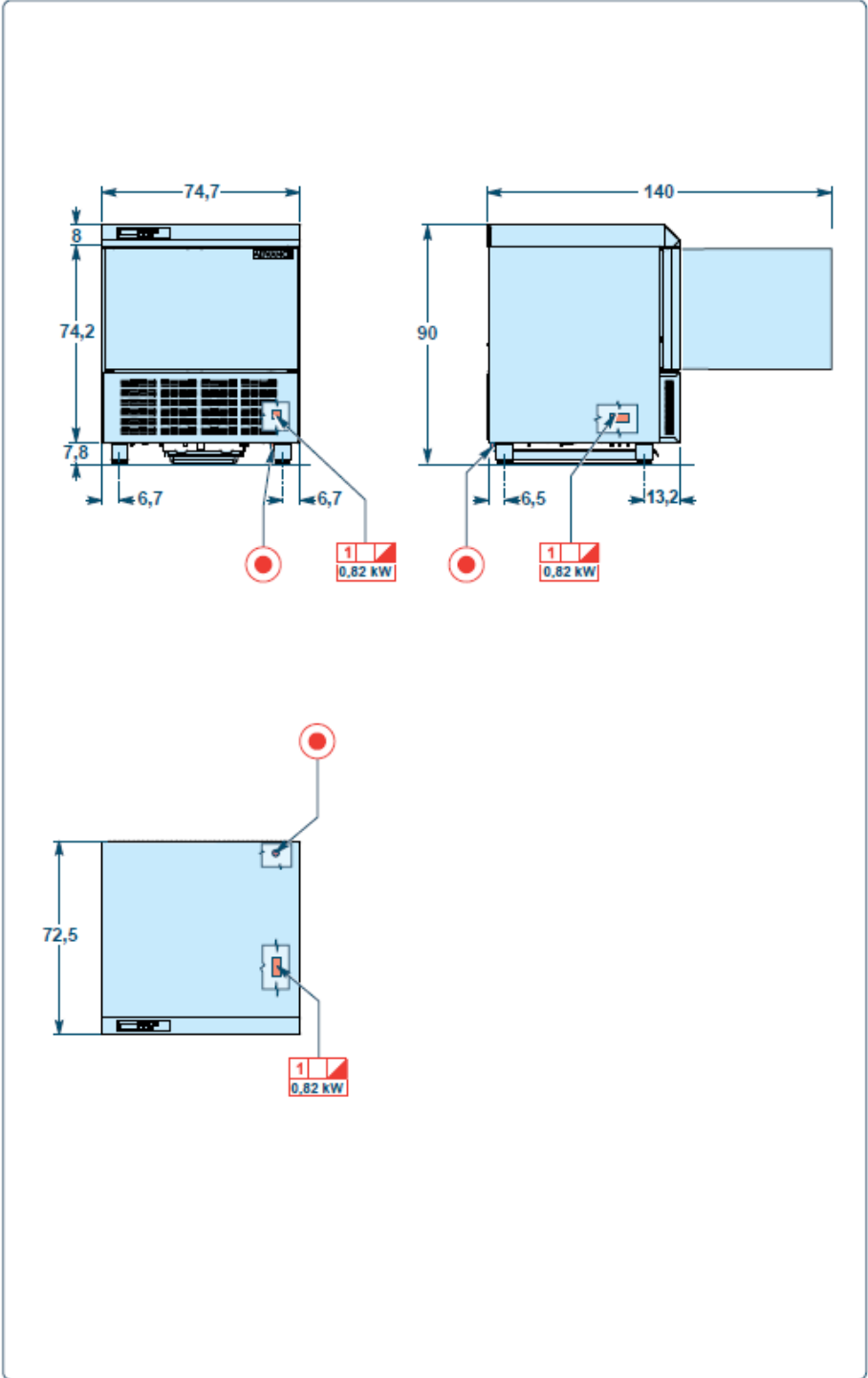

SBU20GTU





 Allacciamento elettrico
 Electric connection
 Branchement électrique
 Elektroanschluss
 Conexión eléctrica



 Morsettiera
 Terminal board
 Plaque à bornes
 Klemmbrett
 Tablero de bornes
 1-N $\frac{1}{2}$
 230 V

Progetto - Lay Out - Projet - Entwurf - Proyecto	Area - Area - Area - Zone - Area	Posizione - Item - Position - Position - Posición
Offerta - Offer - Offre - Angebot - Oferta	Area - Area - Area - Zone - Area	Posizione - Item - Position - Position - Posición

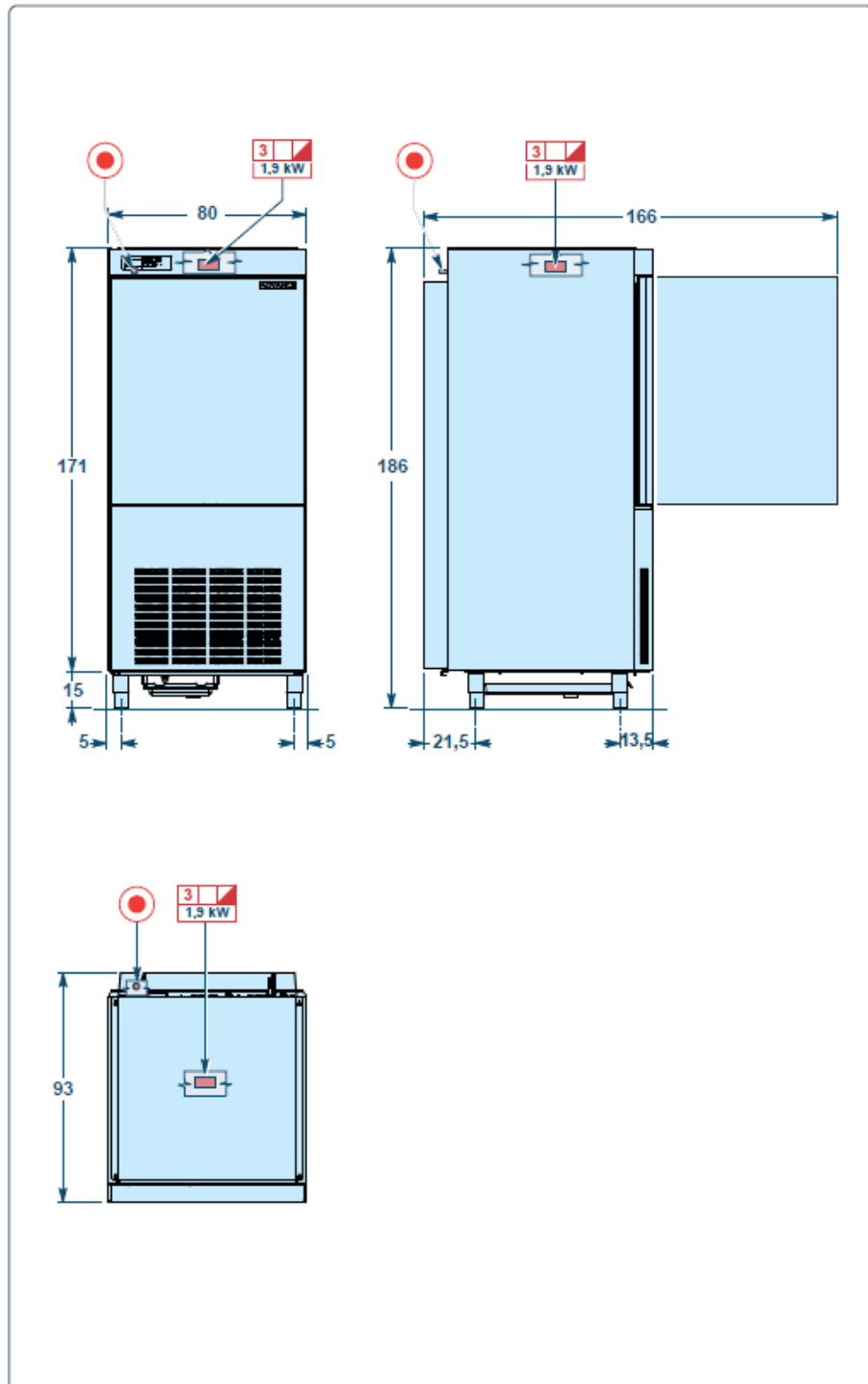

SBU40GT





 Allacciamento elettrico
 Electric connection
 Branchement électrique
 Elektroanschluss
 Conexión eléctrica

 Morsetiera
 Terminal board
 Plaque à bornes
 Klemmbrett
 Tablero de bornes
 3-N
 400 V

Progetto - Lay Out - Projet - Entwurf - Proyecto	Area - Area - Area - Zone - Area	Posizione - Item - Position - Position - Posición
Offerta - Offer - Offre - Angebot - Oferta	Area - Area - Area - Zone - Area	Posizione - Item - Position - Position - Posición

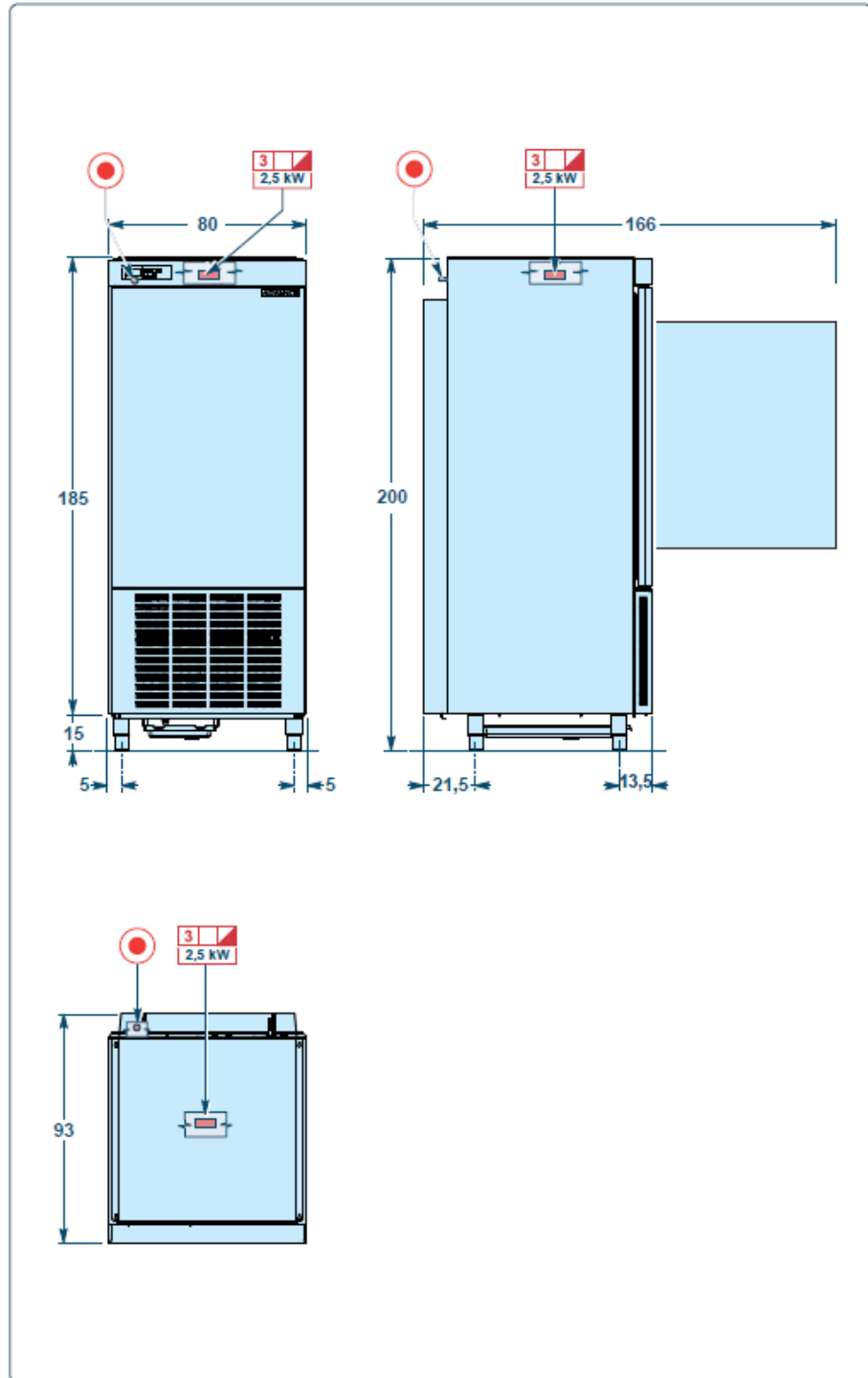

SBU65GT



Allacciamento elettrico
 Electric connection
 Branchement électrique
 Elektroanschluss
 Conexión eléctrica

Morsetiera
 Terminal board
 Plaque à bornes
 Klemmbrett
 Tablero de bornes

Progetto - Lay Out - Projet - Entwurf - Proyecto	Area - Area - Area - Zone - Area	Posizione - Item - Position - Position - Posición
Offerta - Offer - Offre - Angebot - Oferta	Area - Area - Area - Zone - Area	Posizione - Item - Position - Position - Posición



2.2. INSTALLATION AND INSPECTIONS NOTES

AMBIENT TEMPERATURE

For correct operation, the outside temperatures must be between 15°C and 40°C. Make sure that the room has a proper air exchange.

POSITIONING

The unit must be installed and tested in full compliance with accident prevention laws, EU directives and current regulations. The installer is obliged to check any prescriptions imposed by local authorities.

- Place the machine in the prescribed location.

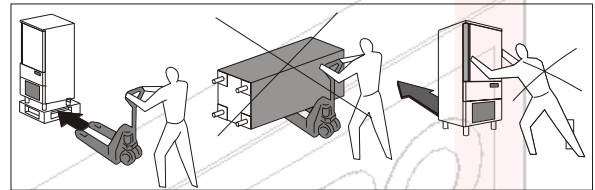

- Avoid places exposed to direct sunlight
- Avoid enclosed places with high temperatures and poor air exchange.
- Avoid installing the machine near any heat source.

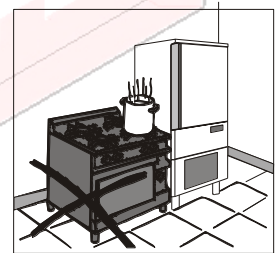

- Maintain a minimum distance of 100mm from the air inlet and outlet sides of the machine compartment.

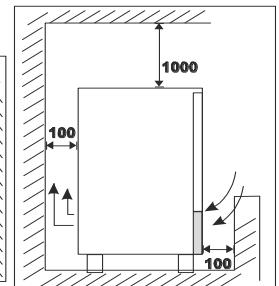
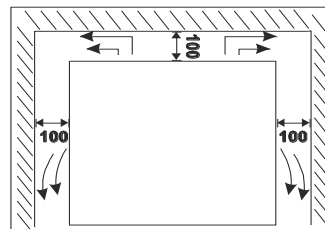

- Level the unit using the adjustment feet.

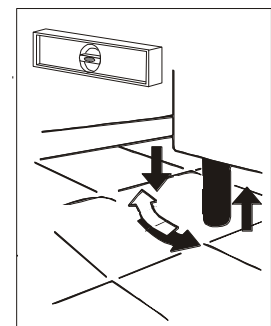

CAUTION: If the units are not levelled, their operation and the outflow of condensation may be impaired.



ELECTRICAL CONNECTION

The electrical connection and connection systems of the unit must comply with the regulations in force in the country of installation and must be carried out by qualified personnel authorised by the manufacturer.

CAUTION: do not use adapters or extension cords for connection to the mains.

DO NOT USE ADAPTER PLUGS. Due to safety hazards that may arise in certain situations, the use of adapter plugs is strongly discouraged.

DO NOT USE EXTENSION CORDS. The manufacturer does not guarantee the unit if an extension cord is used.

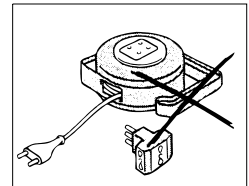

WARNING: any damaged power cord must be replaced by the manufacturer, after-sales service, or qualified personnel to prevent risks.

Check that the mains voltage corresponds to the voltage stated on the technical rating plate of the unit.

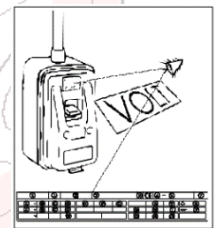

CAUTION: The unit must be connected to an effective earthing system .

CAUTION: It is compulsory to insert the unit into an equipotential system according to the regulations in force. The connection must be made between the different units via the equipotential terminal .

CAUTION: A thermal-magnetic circuit breaker must be installed upstream of the unit in accordance with the regulations in force in the country of installation.

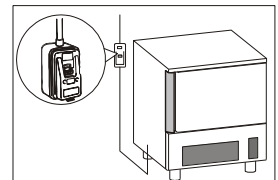

The electrical mains cables must be correctly sized and selected based on the installation conditions.

The electrical connection is carried out from the rear part.

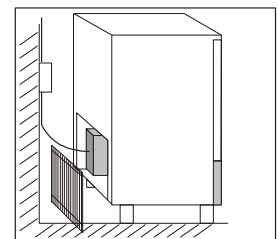

10kg models are equipped with 3m of single-phase cable (3G 1.5mm²) with a SHUKO plug.

Use of any other type of electrical connection or modifying the size of the cable by less than its length is not permitted. Take care to replace it with one having identical characteristics to the original.

20kg models are equipped with 3.5m of cable for three-phase power supply (5G 2.5mm²) without a plug.

Fit an electrical plug (not supplied) of a type and capacity suitable for the maximum current absorbed by the unit or make a direct connection to an electrical panel.



The manufacturer declines all responsibility and any obligation to warranty if damage occurs to the equipment, persons or things, imputable to incorrect installation and/or non-compliance with applicable laws and tampering with any part of the unit (electrical, thermodynamic or hydraulic system).

COMMISSIONING

If the equipment was transported horizontally instead of vertically, DO NOT POWER IT UP BUT WAIT AT LEAST **24 HOURS** BEFORE OPERATION.

The manufacturer declines any responsibility and any warranty obligation if damage occurs to the equipment imputable to transportation in a horizontal position.

Respect the outside temperatures which must be between 15°C and 40°C.

Power up the unit and wait 30 minutes before use if the outside temperature is "low".

Check absorption

Carry out at least one complete blast-chilling cycle in order to verify correct operation

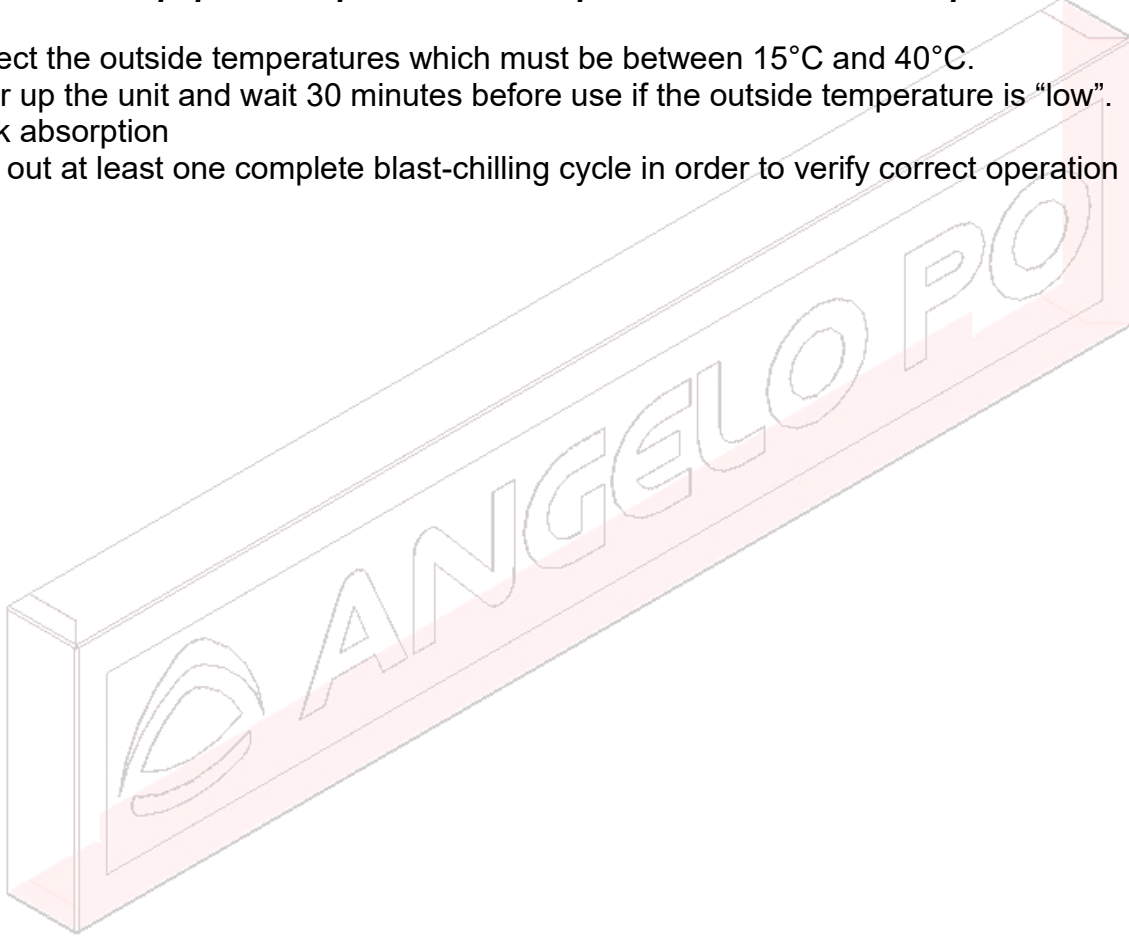

INDEX

 3. MAINTENANCE: PART 1	22
3.1 MATE-N-LOK MAINTENANCE	22
3.2 BOARD MAINTENANCE	27
3.3 POWER BOARD MAINTENANCE	30
3.4 MAGNETIC MICRO MAINTENANCE	32
3.5 DOOR SEAL MAINTENANCE	34
3.6 FRAME PROFILE COOL PROTECTION RESISTANCE MAINTENANCE	36
3.7 DOOR/BRACKET MAINTENANCE	43
3.8 ELECTRICAL PANEL AND SUB-COMPONENT MAINTENANCE	45
3.9 FUSE MAINTENANCE	48
3.10 CONTACTOR MAINTENANCE	49
3.11 REMOVING THE MATE-N-LOK FEMALE CONNECTOR	49
3.12 EVAPORATOR FAN MAINTENANCE	51

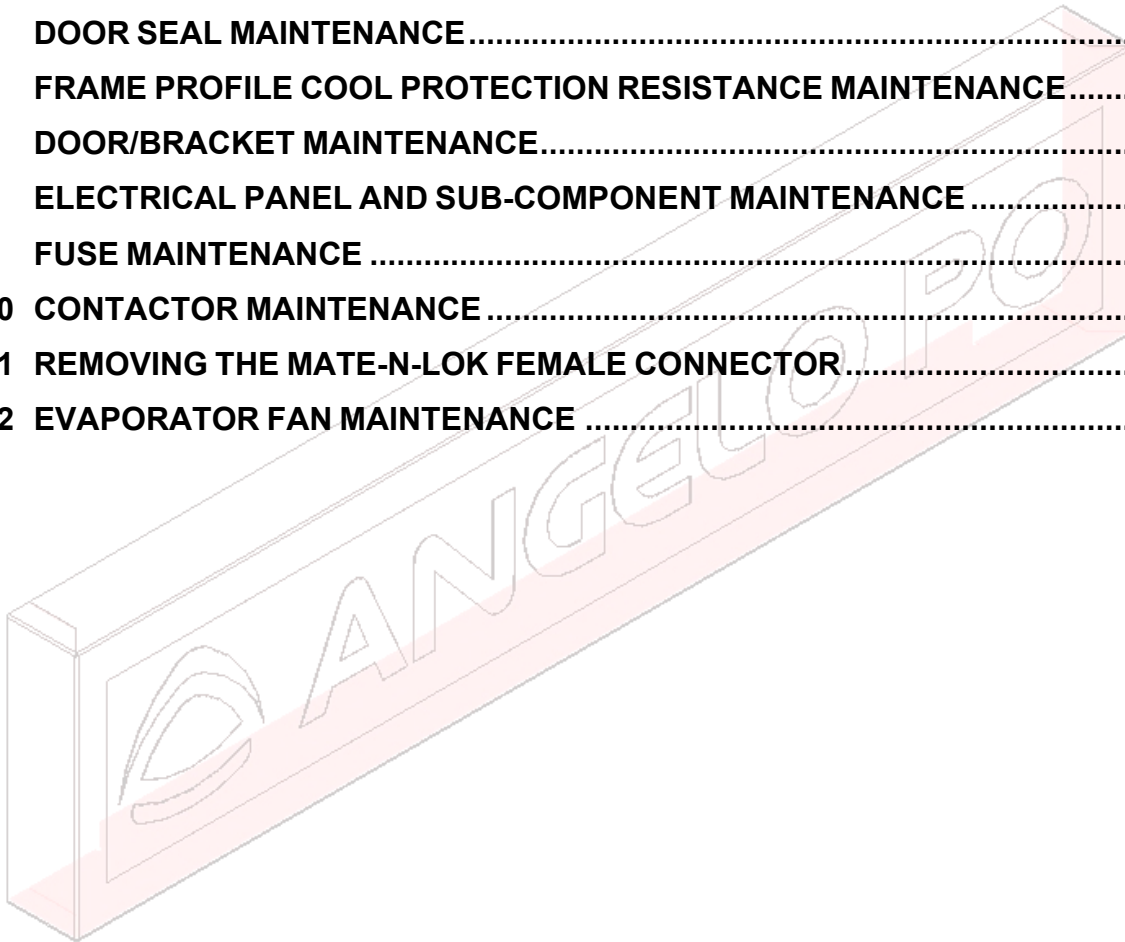



3. MAINTENANCE: PART 1

3.1 MATE-N-LOK MAINTENANCE

Mate-n-lok connections are Male-Female quick connectors where the male connector is used for wiring internal components and the female connector is installed on electrical panels.

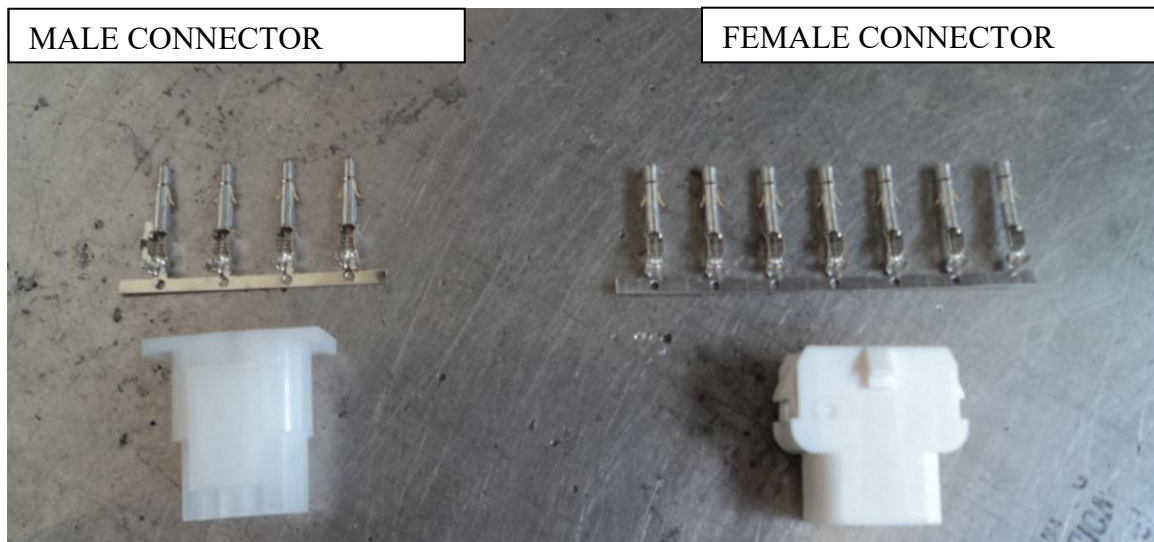

Figure 1

To perform maintenance on a Mate-n-lok connection

- I. Disconnect the unit from the electrical mains.
- II. Uncouple the connector to be restored.
- III. Uncouple the Mate-n-lok using a small diameter screwdriver: Bend the internal fins as indicated in the figure to slide the metal part off of the connector.



Figure 2

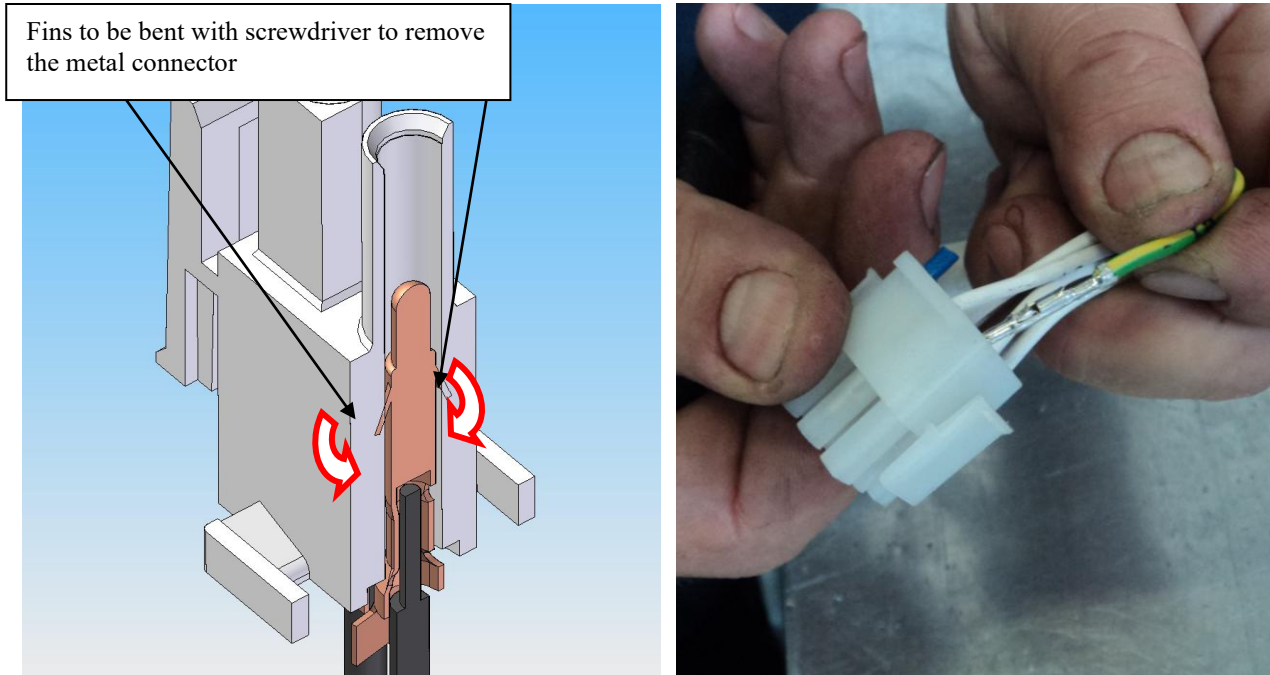

Figure 3

- IV. Remove the metal connector, using a screwdriver to bend the metal fins keeping it anchored to the electrical cable.
- V. If necessary, remove the wire sheath, leaving about 8-10 mm of copper in sight.

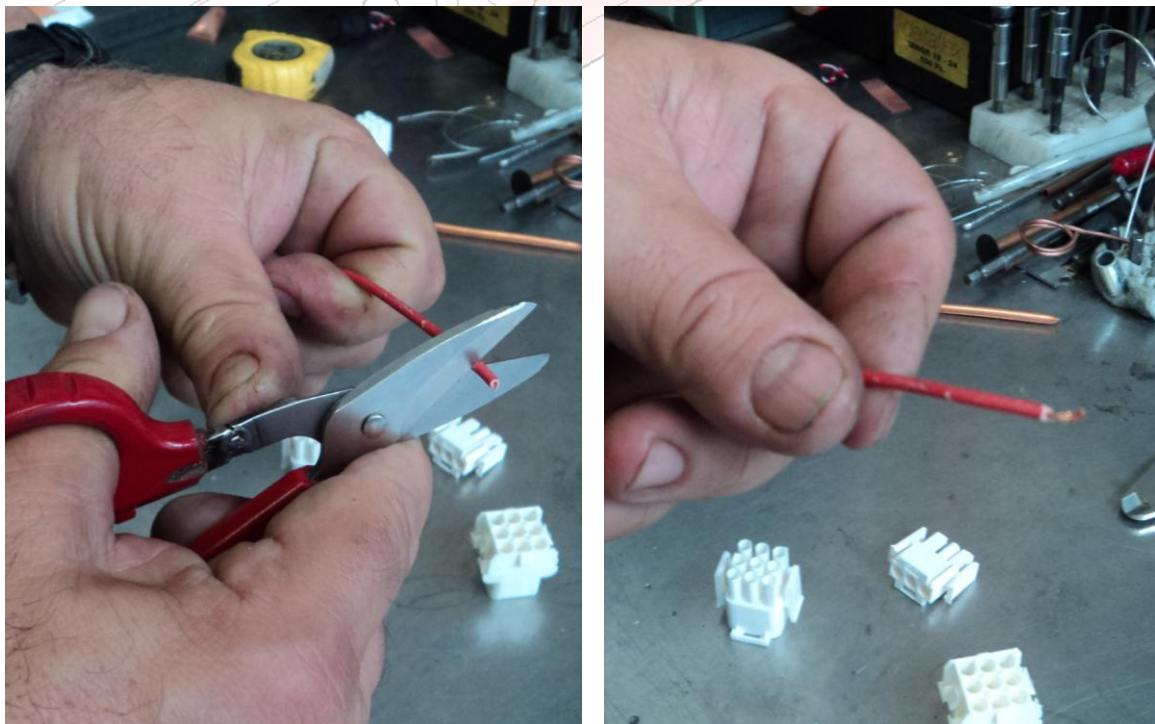

Figure 4



- VI. Insert the previously prepared wire in the new metal connector as shown in the figure.

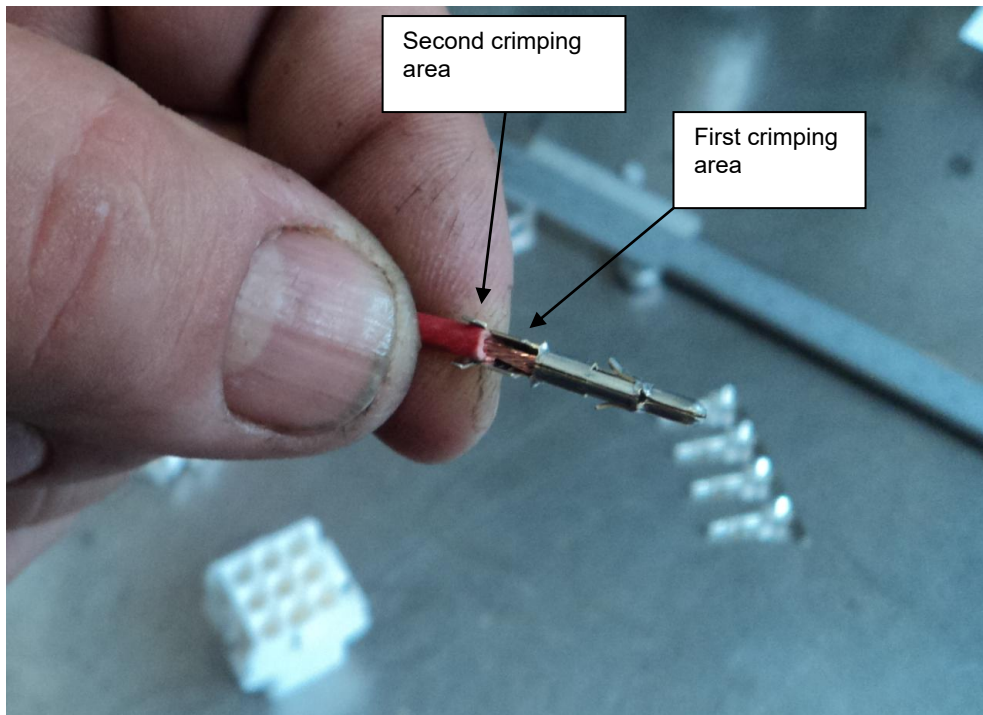

Figure 5

- VII. Use crimping pliers to fasten the Mate-n-lok to the electrical wire: The metal component should be crimped in two phases in the area shown in the previous figure.



Figure 6



- VIII. After having ensured correct crimping of the metal connector, insert the new mate-n-lok in the plastic terminal. **The connector should be inserted down to the bottom to permit the fins to attach into their housing (click).** See the wiring diagram for correct positioning of the metal connector in the terminal block.

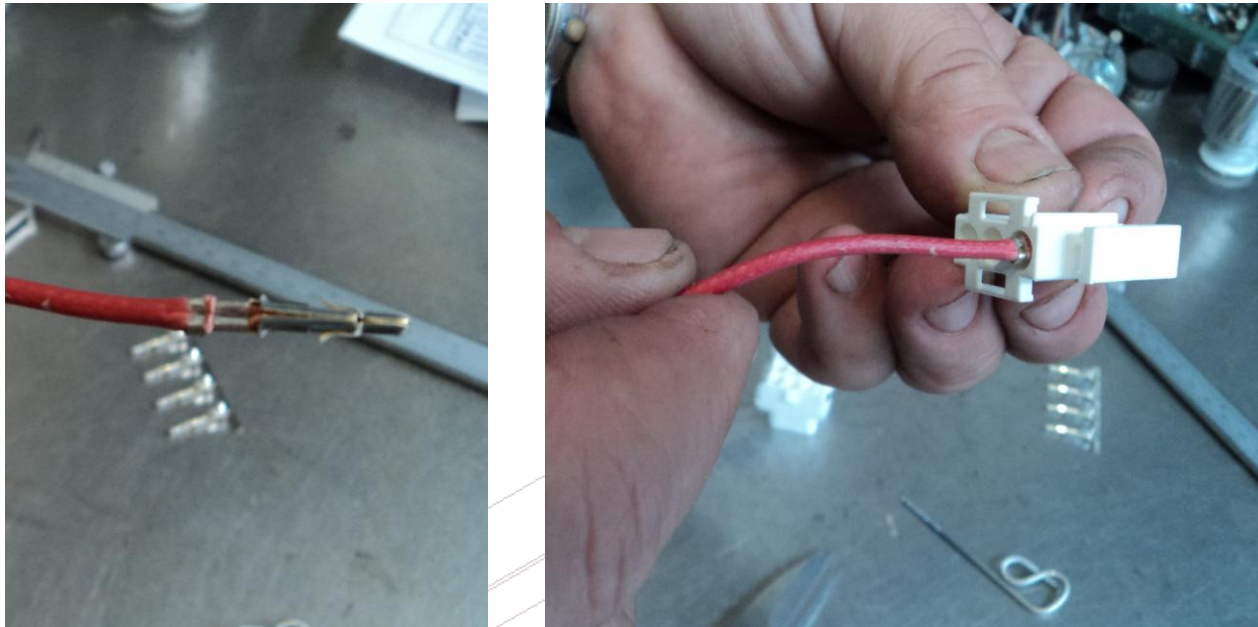

Figure 7

- IX. Re-couple the male-female mate-n-lok connector. To detach the connector, press on the side fins as indicated in the figure.

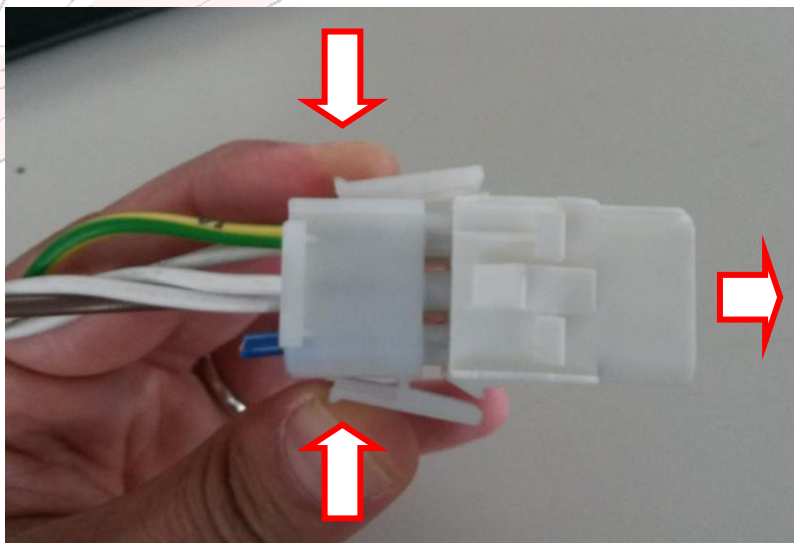

Figure 8



- X. Mate-n-lok connections can be identified by means of clearly visible letters both on the male and on the female connectors. These same letters are also contained in the wiring diagram.



Figure 9



3.2 BOARD MAINTENANCE



Before proceeding with maintenance operations on panel kits, electrical panels or any other electronic or electromechanical component, use insulating personal protective equipment (gloves) and discharge any residual current to avoid the risk of electric shock. If possible, it is advisable to operate with the panel kit placed on an earthed antistatic mat and wearing an ESD bracelet.

Note: To replace the board on blast chillers in this range, it will also be necessary to replace the screen printing, as the removal procedure could damage it.



SBU15GL...

- I. Remove the condenser protective panel, open the panel kit (only for SBU15GLE) to access the board. Proceed with steps II-V.



Figure 10

SBU20GL...

- III. Remove the instrument panel kit from the pins on the structure. Remove the screen printing and the rear panel covering the push-button panel. Remove the push-button panel fixing screws to replace the component.

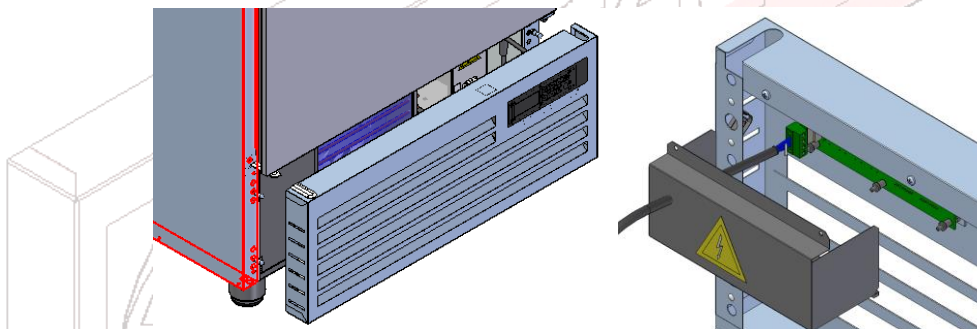

Figure 11

SBU20GT...

- IV. Disassemble the surface by unscrewing the vertical screws on the brackets (one on each side) and rotate the surface after removing the screen printing. Remove the reinforcement protecting the push-button panel and remove the component to be replaced.

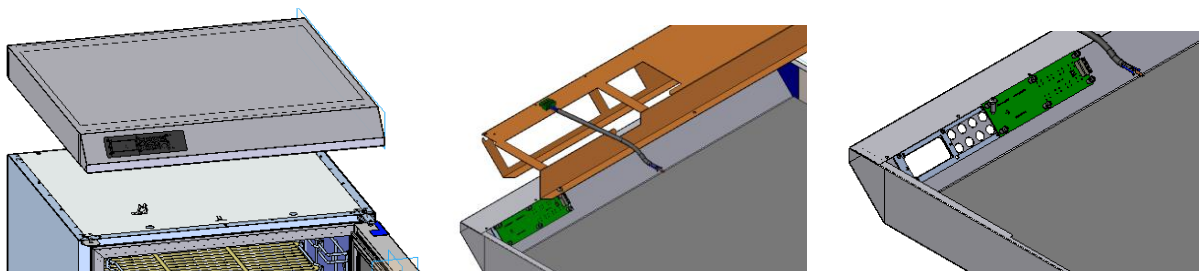
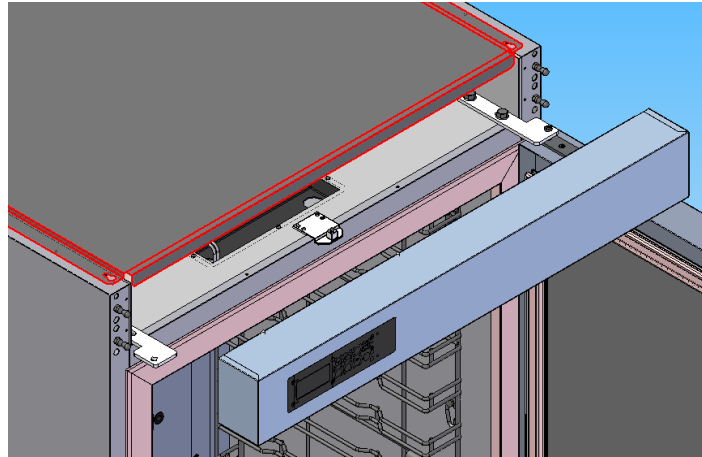
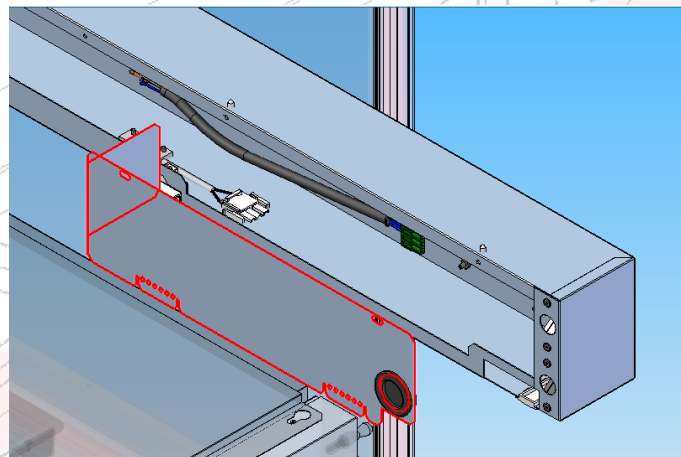
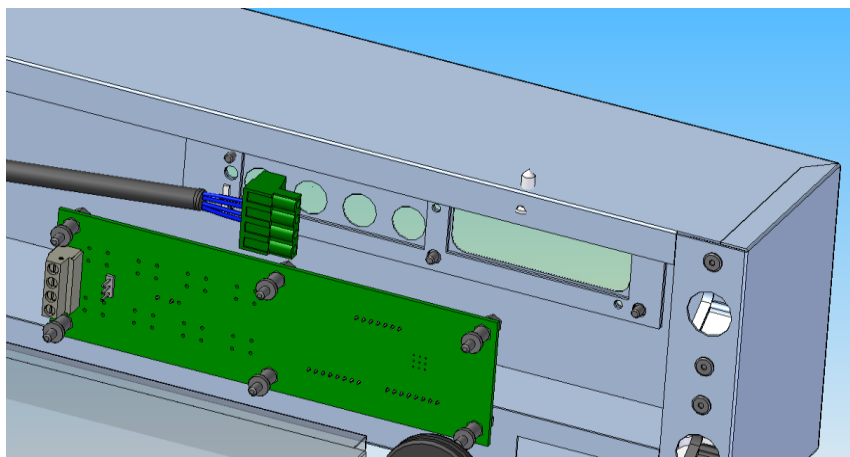

Figure 12

**SBU40GT – SBU65BTU**

- V. Remove the screw holding the instrument panel in place and unhook the instrument panel kit from the 4 pins on the structure. Remove the panel protecting the circuit board.

**Figure 13****Figure 14****Figure 15**



3.3 POWER BOARD MAINTENANCE

SBU15GL...-SBU20GL...-SBU20GT...

- XI. Remove the panel protecting the condensing coil. Remove the panel retaining screw and remove the panel, taking care with the cables at the back. To facilitate removal, remove the rear mesh to untangle the cables. Remove the panel kit cover panel to access the power board.

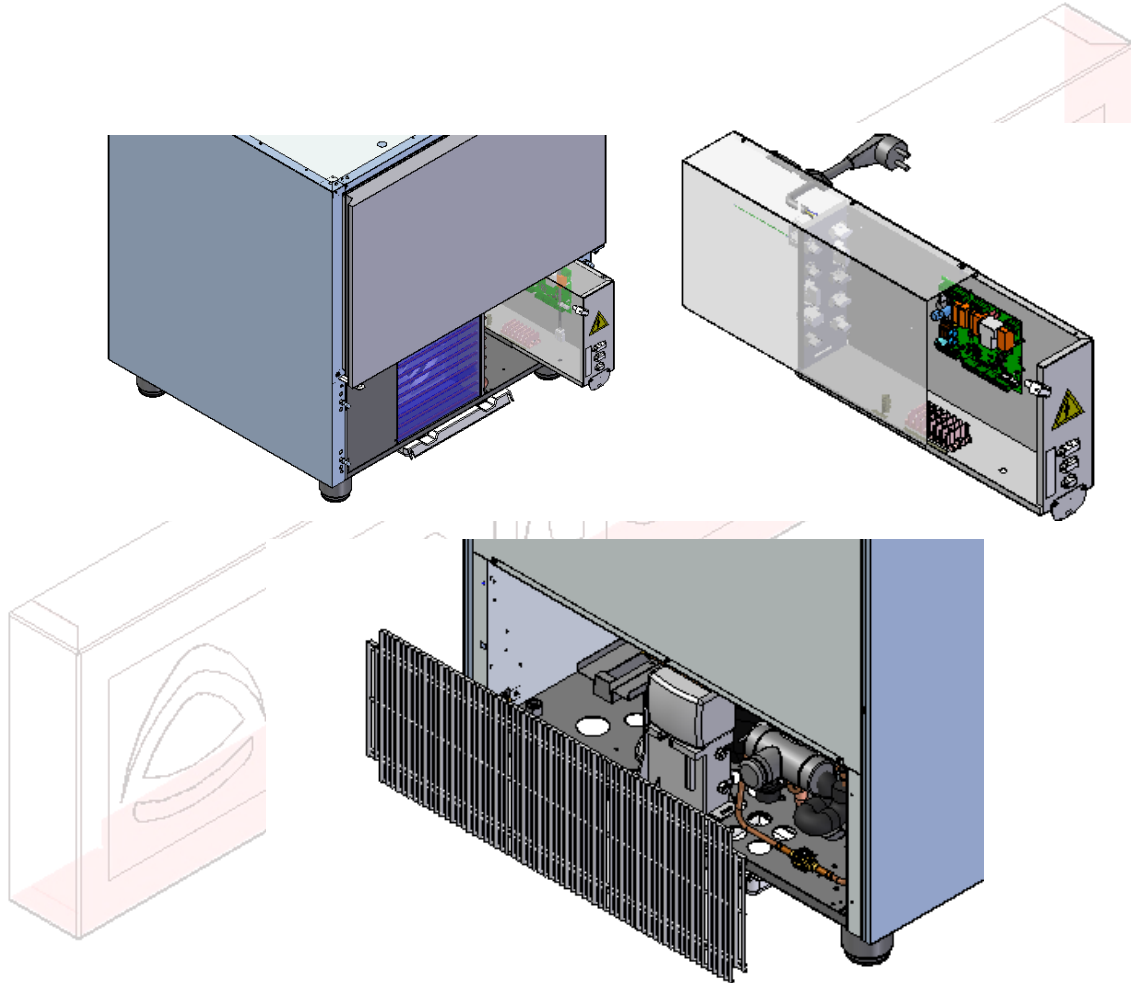

Figure 16

**SBU40GT-SBU65GTU**

- XII. Remove the upper panel to access the electrical panel. Remove the cover panel to access the power board.

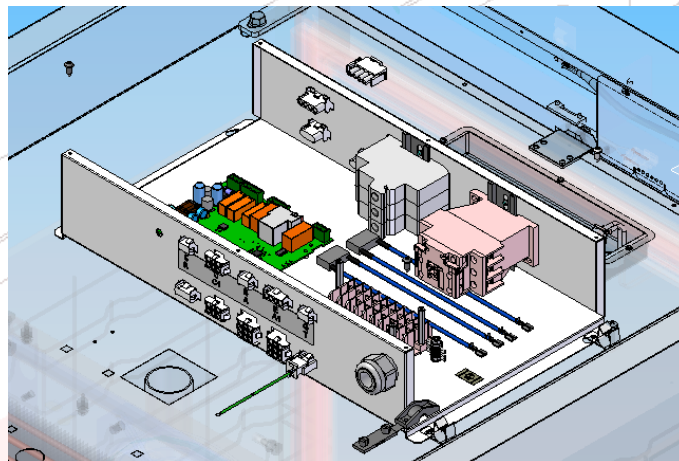
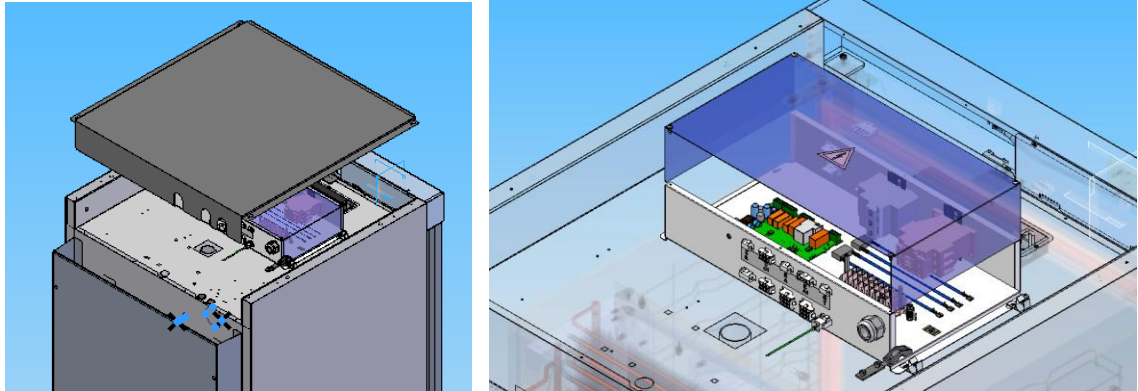

Figure 17



3.4 MAGNETIC MICRO MAINTENANCE

SBU20GL...-SBU20GT...

- XIII. Dismantle the condenser protective panel, pulling it in the direction indicated in figure 11.
- XIV. Remove the magnetic micro unscrewing the fastening nuts.



Figure 18

- XV. Remove the plate inside the wiring protection.

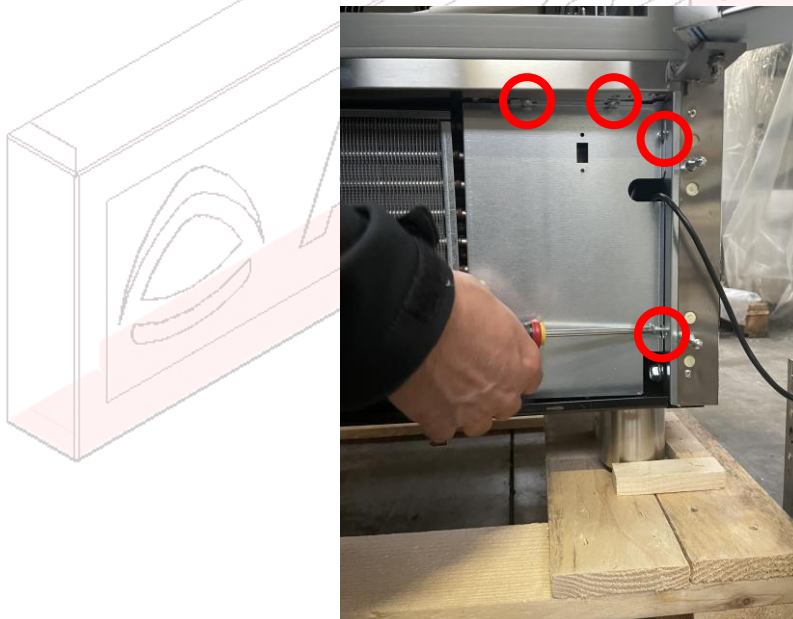

Figure 19

- XVI. Cut the grips to free the magnetic micro cable.
- XVII. Disconnect Terminal "F" and remove the cable + micro.
- XVIII. Reassemble the new micro, repeating operations in the reverse order.

**SBU15GL...**

XIX. In the case of the SBU15GL..., the electrical panel is located in the condenser protective panel, so follow the same steps.



Figure 20

SBU40GT-SBU65GT

XX. For these models, the micro is located in the lower part of the instrument panel kit situated at the top of the blast chiller. Remove the instrument panel kit as shown in the figure and proceed with the same operations as in the previous paragraphs.

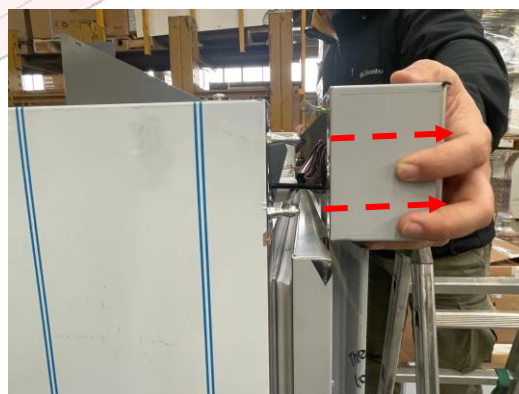

Figure 21



3.5 DOOR SEAL MAINTENANCE

- *CLEANING*

Manually folding the seal lip and wipe with a cloth as illustrated. Repeat this operation over the entire perimeter and on both sides of the seal.



Figure 22

- *REPLACEMENT*

In the event that replacement is required, manually remove the seal from its housing along the entire perimeter.



Figure 23



Assemble the new seal by inserting it manually into the housing.

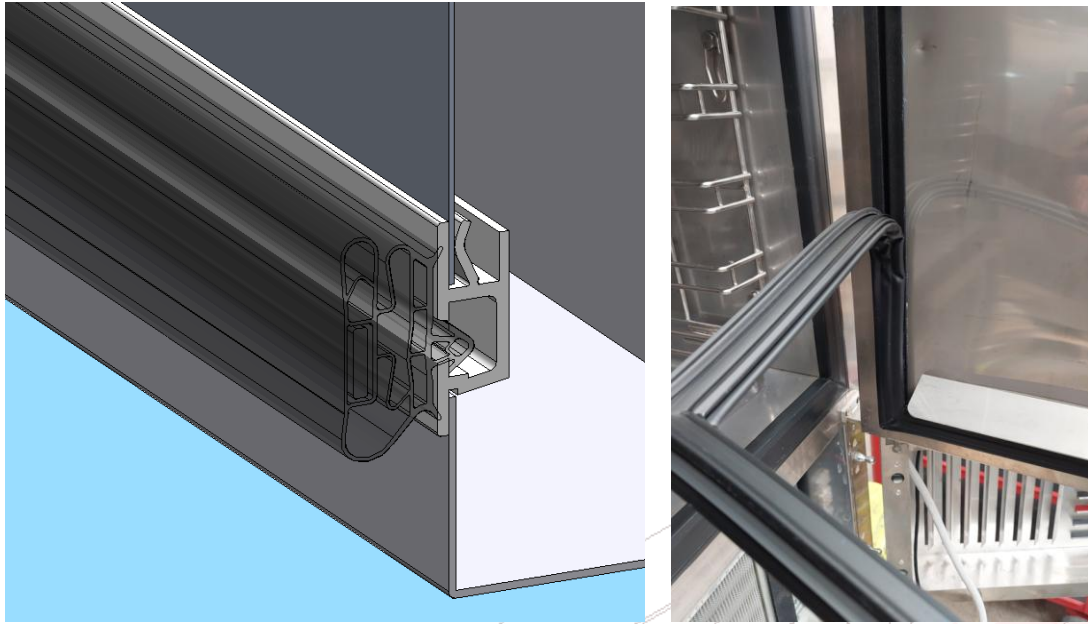

Figure 24

Use a soft material hammer to correctly place the seal in its housing, starting from the four corners and then continuing along the entire perimeter.

Check that the gasket has been correctly inserted into the housing groove.



Figure 25



3.6 FRAME PROFILE COOL PROTECTION RESISTANCE MAINTENANCE

- I. Remove the condenser protective panel to uncover the panel kit. On the SBU15GL..., the panel kit is mounted directly on the condenser protective panel (figure 11), while on the SBU20GL... and SBU20GT... models, the panel kit is positioned in a “boxed” metal sheet behind the condenser panel (figure 12).

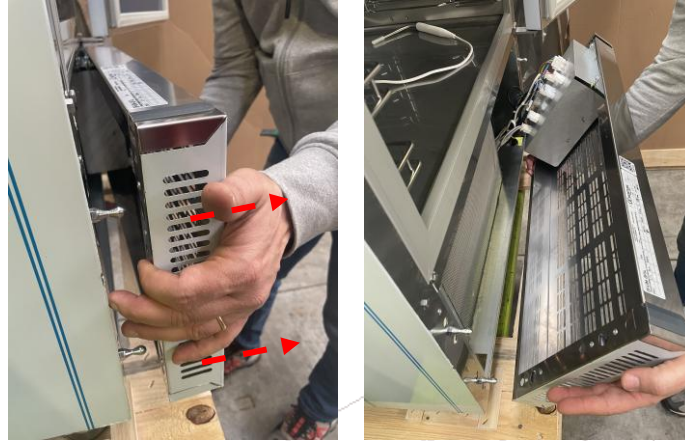

Figure 26

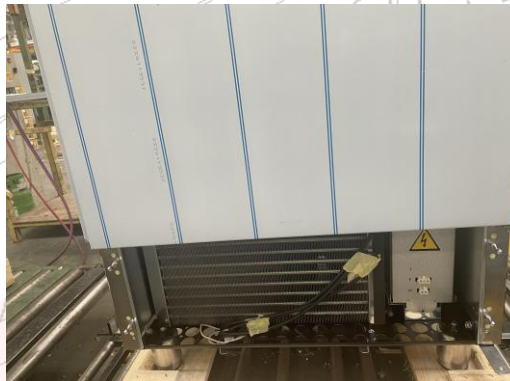

Figure 27

- II. Disconnect the Mate-n-lok labelled “H” by pressing firmly on its side tabs, as shown in figure 13, and pulling the connector out of its slot.



Figure 28



- III. Pry up the inner side of the frame lid, taking care not to damage the components.
Repeat this operation on the entire frame profile.



Figure 29

- IV. When removing the frame cover, be careful of the magnetic bars inside which could slip out. If they should slip out, reassemble magnets with the grooved surface facing the inside of the refrigerated compartment.

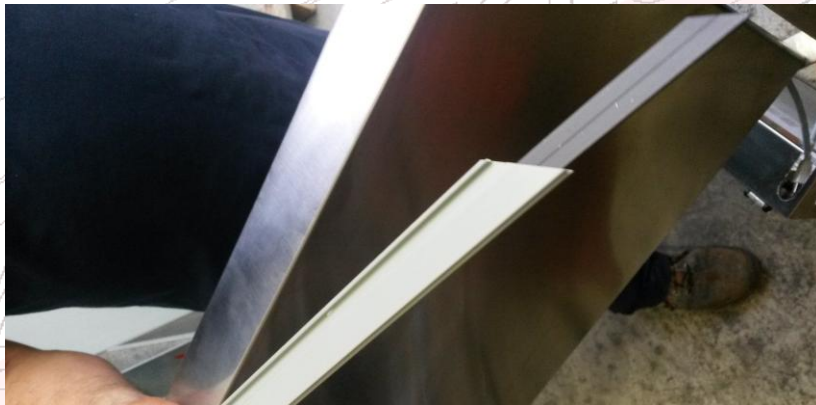

Figure 30

Note: Description of the cool protection resistance path

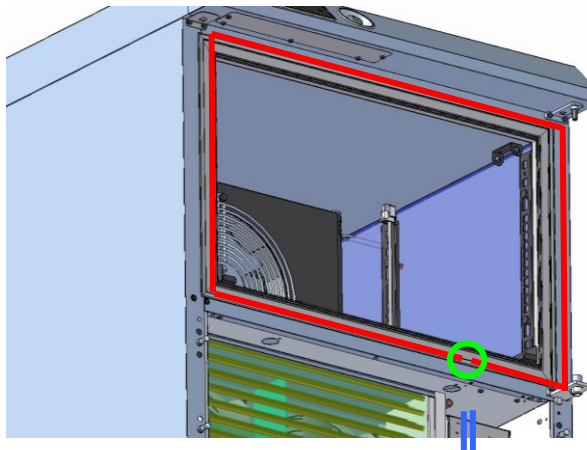

Figure 31



During assembly, the heating element is passed through the frame, in correspondence with the green circle (figure 31), inserted inside the structure, from where it will then exit from the compartment below. Subsequently, following polyurethane injection, the cable will remain trapped inside the structure. To remove the resistance, you will have to remove the polyurethane part in this area.



Figure 32

- V. Using a drill, delicately remove the polyurethane present in the heating element cable passage duct, taking care not to damage the frame and the surrounding plates.



Figure 33



VI. Remove the resistance from its housing, taking care not to damage the frame.



Figure 34

VII. Insert the metal connectors of the new heating element in the duct that has just been opened and insert them into the plastic mate-n-lok terminal in the compartment below. See section 3.2 for details regarding mate-n-lok connectors.



Figure 35



- VIII. The heating element is composed of a hot zone and a cold zone. The hot part is delimited by the two red reference marks.

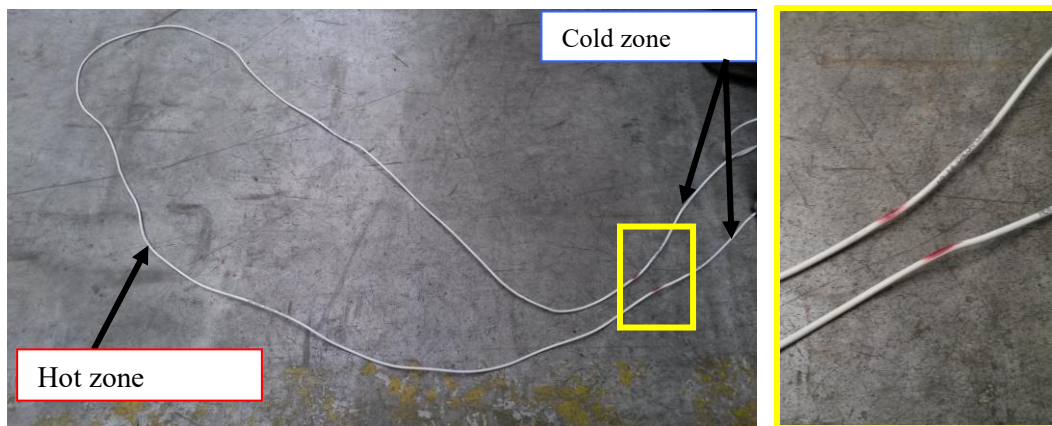

Figure 36

It is important to position the heating element in its housing so that the hot part covers the entire perimeter of the frame and the cold part is instead outside of it.

Avoid contact between the two hot zones of the heating element to prevent burning.

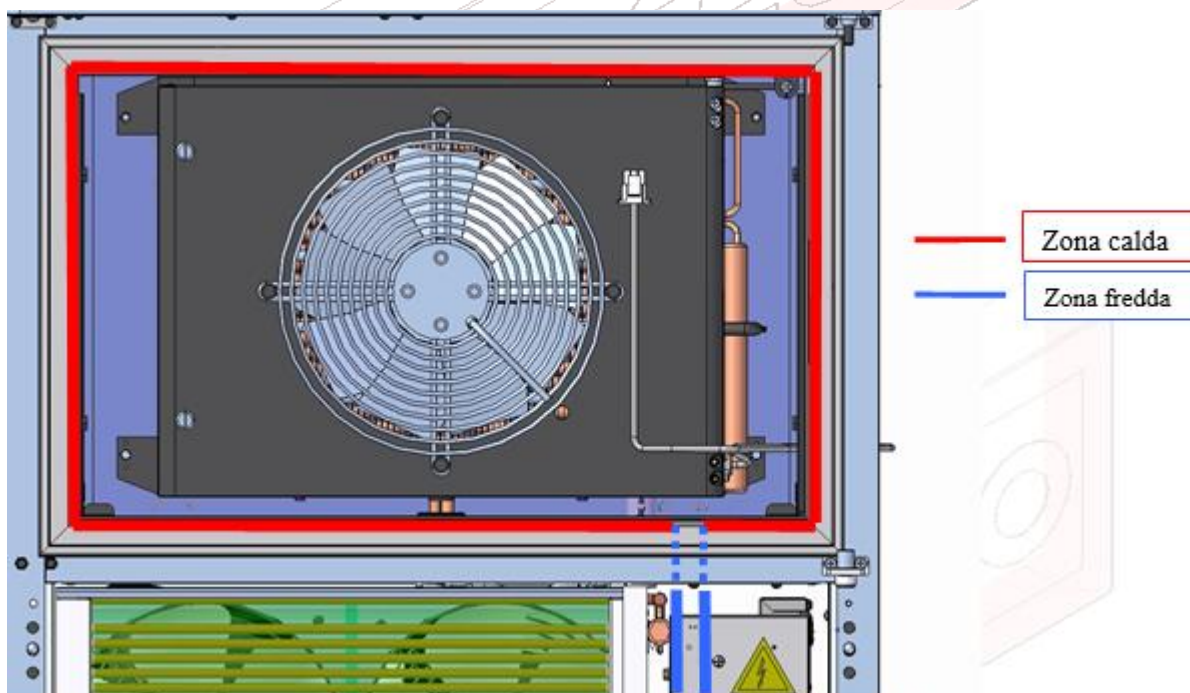

Figure 37

- IX. Fill the wire passage duct with stucco or silicone, sealing the refrigerated chamber as much as possible.
- X. Reassemble the frame cover, first encasing the bottom part in its housing (see figure) and then pressing on the top part.

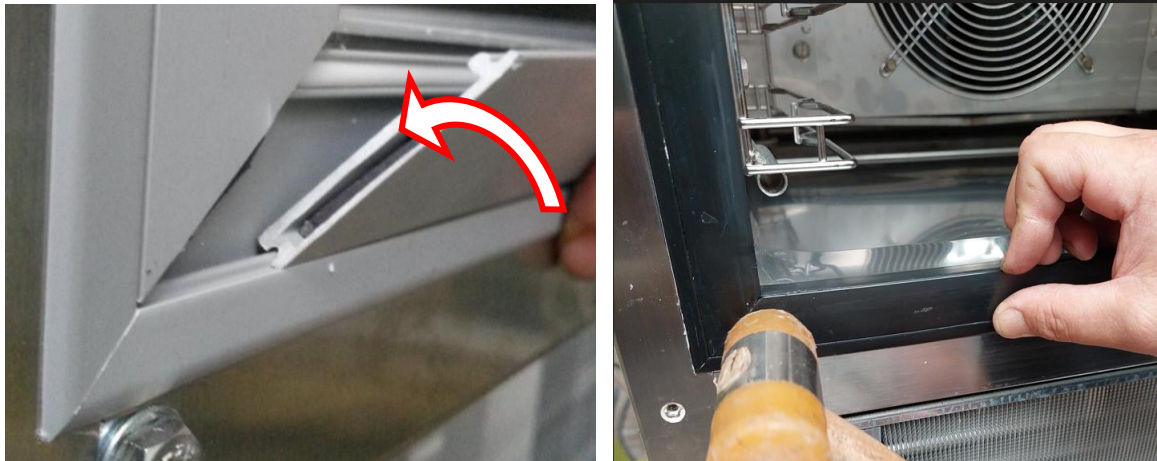
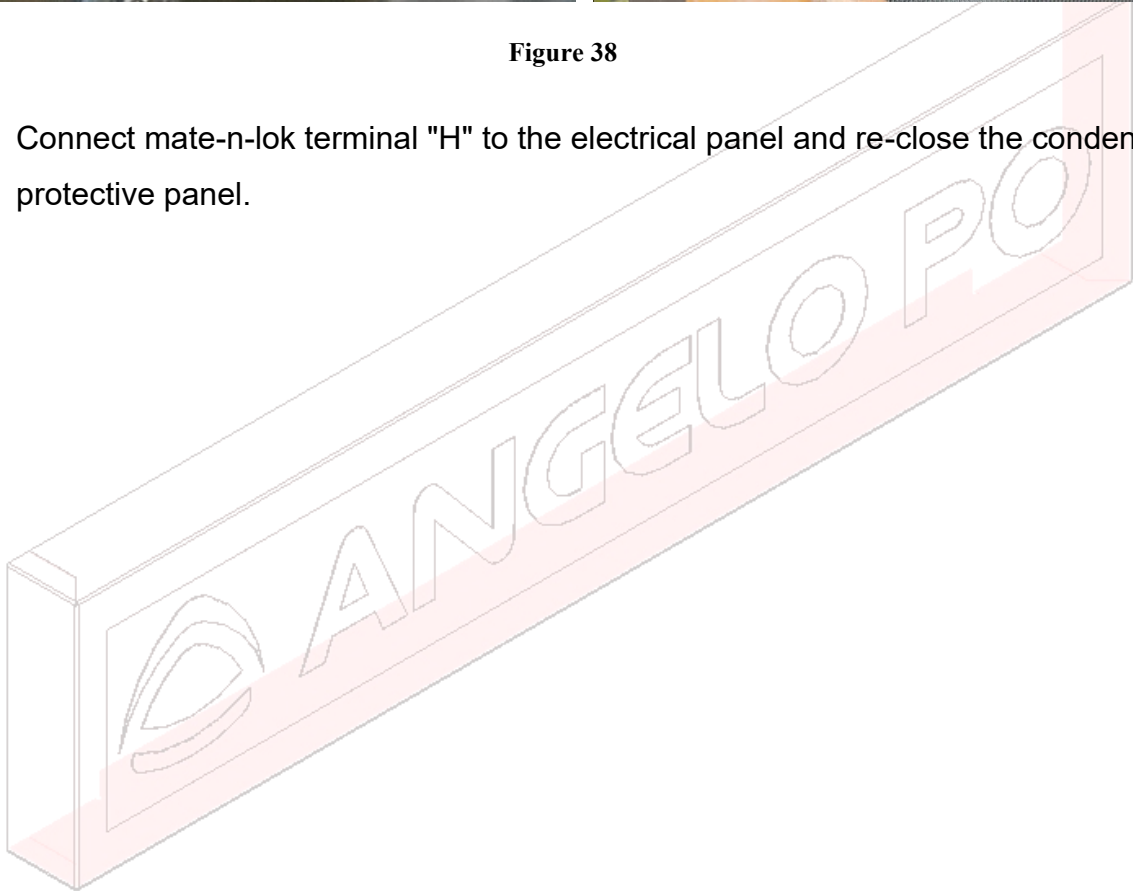

Figure 38

- XI. Connect mate-n-lok terminal "H" to the electrical panel and re-close the condenser protective panel.



**SBU40GT-SBU65GT**

- XII. In models SBU40GT and SBU65GT the panel kit is located on the external ceiling, under the protective plate. Use a ladder to reach and loosen the 4 screws indicated by the red arrows that secure the plate to the structure (there is no need to unscrew the screws completely). Slide the plate towards the back of the machine (as indicated by the light blue arrow) along the slots and remove it by lifting it.

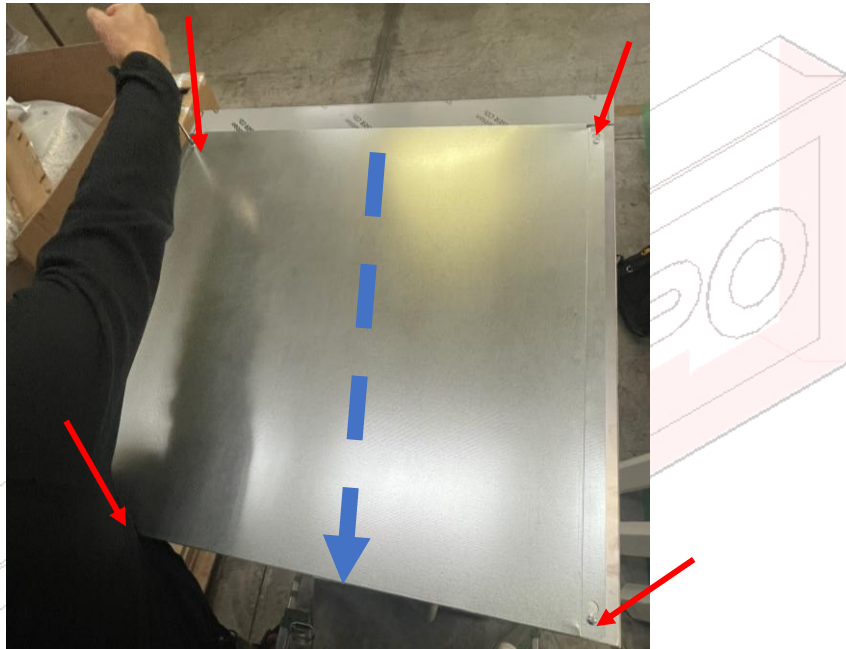
**Figure 39**

- XIII. Disconnect the mate-n-lok clamp “H” from the electrical panel. Cut the grips and remove the heating element from the cable protection, repeating the same procedures described for models SBU15GL..., SBU20GL... and SBU20GT...

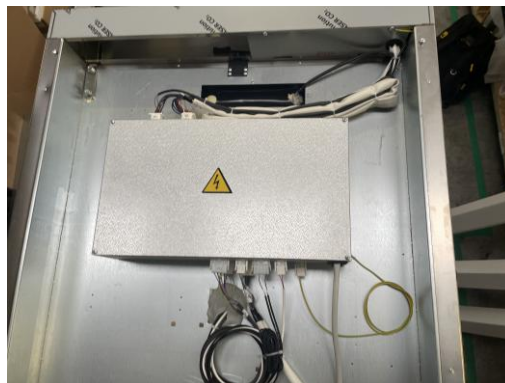
**Figure 40**

- XIV. When reassembling the new heating element, follow the instructions described above.



3.7 DOOR/BACKET MAINTENANCE

Proceed as follows to replace the door.

- I. Each bracket has two screws positioned horizontally that secure the bracket to the structure and a vertical screw to secure the top. Unscrew the four vertical screws for the bracket-top assembly from the structure.



Figure 41

- II. Raise the top slightly so as to extract the pin of the upper bracket inserted in the respective insert of the door and remove the door by tilting it outwards and lifting it from the lower bracket.

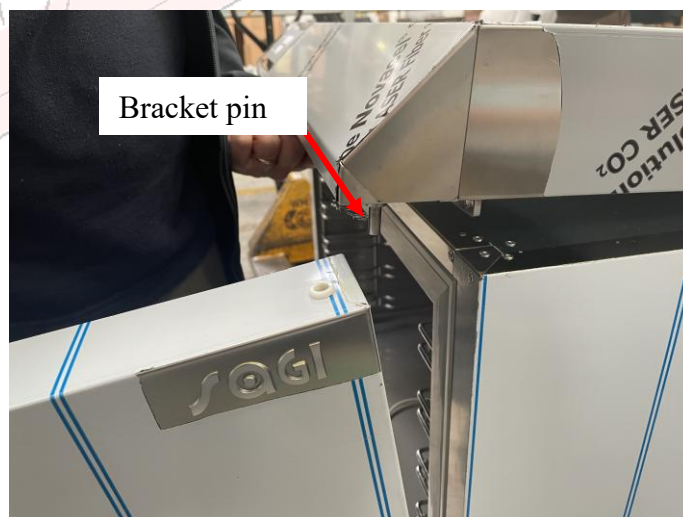

Figure 42



- III. To replace the brackets, unscrew the remaining two vertical screws (one per bracket) and proceed with replacement.



Figure 43

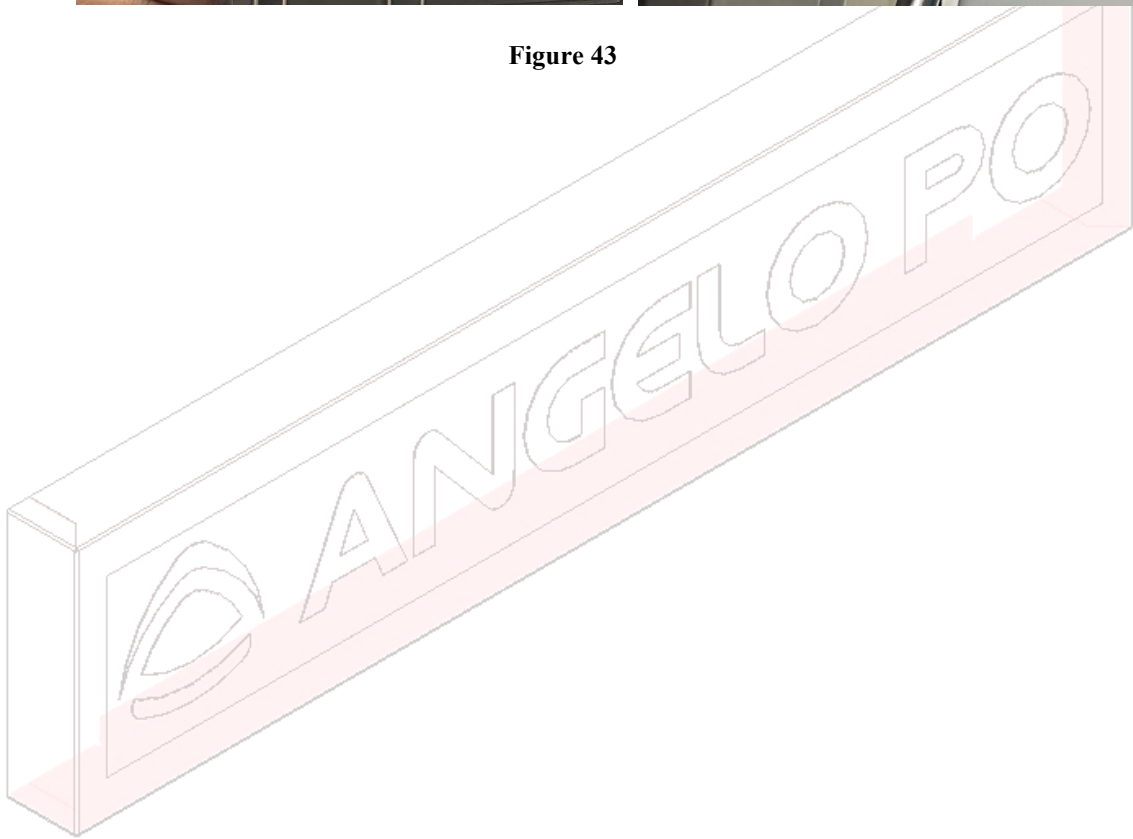



3.8 ELECTRICAL PANEL AND SUB-COMPONENT MAINTENANCE

Proceed as follows to perform electrical panel maintenance.

- I. Remove the condenser protective panel and any wiring protection plates as previously described. Disconnect all the mate-n-lok terminals.

SBU15GLE

- II. Unscrew the two screws and slide the panel kit in the direction indicated in the figure to reveal the wiring and the board.

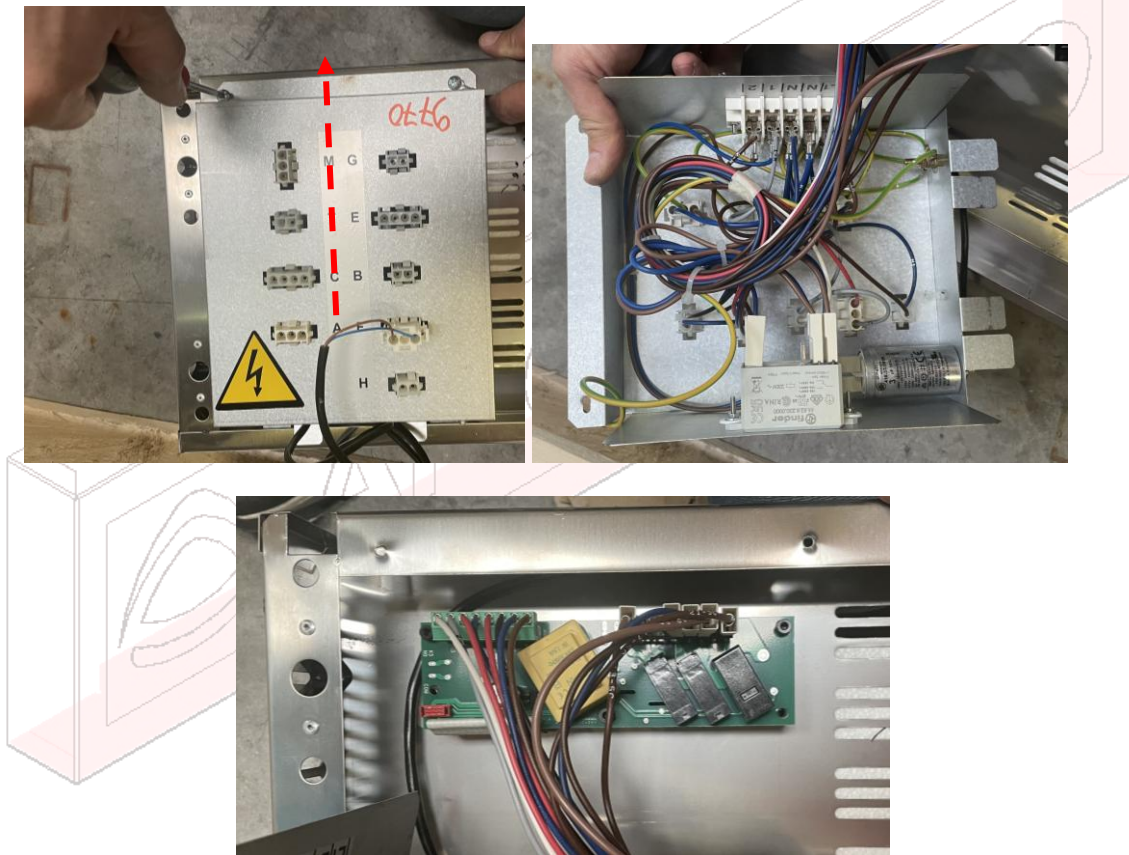

Figure 44

**SBU20GL...-SBU20GT...**

III. Remove the screws shown in the figure and remove the electrical panel.

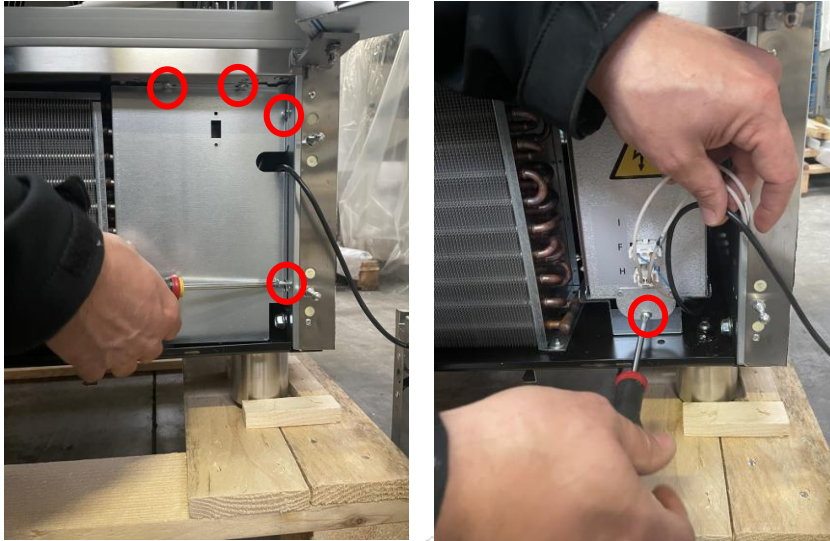

Figure 45

IV. Unscrew the top screws fastening the top panel plate.



Figure 46

V. Remove the top plate and reveal the panel kit components.

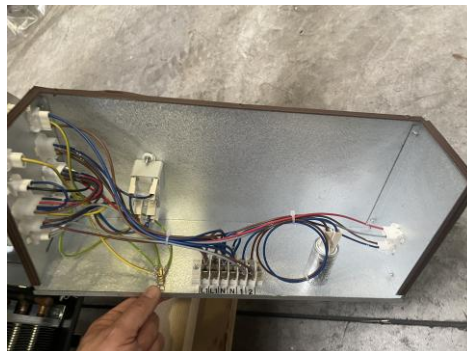

Figure 47

**SBU40GT-SBU65GT**

The electrical panel is located in the upper part on models SBU40GT and SBU65GT.

- VI. Remove the upper protection plate as previously described.
- VII. Unscrew the 4 screws indicated in the figure to remove the cover plate and reveal the electrical panel (Note: a copy of the wiring diagram is affixed to the inside of the cover plate)

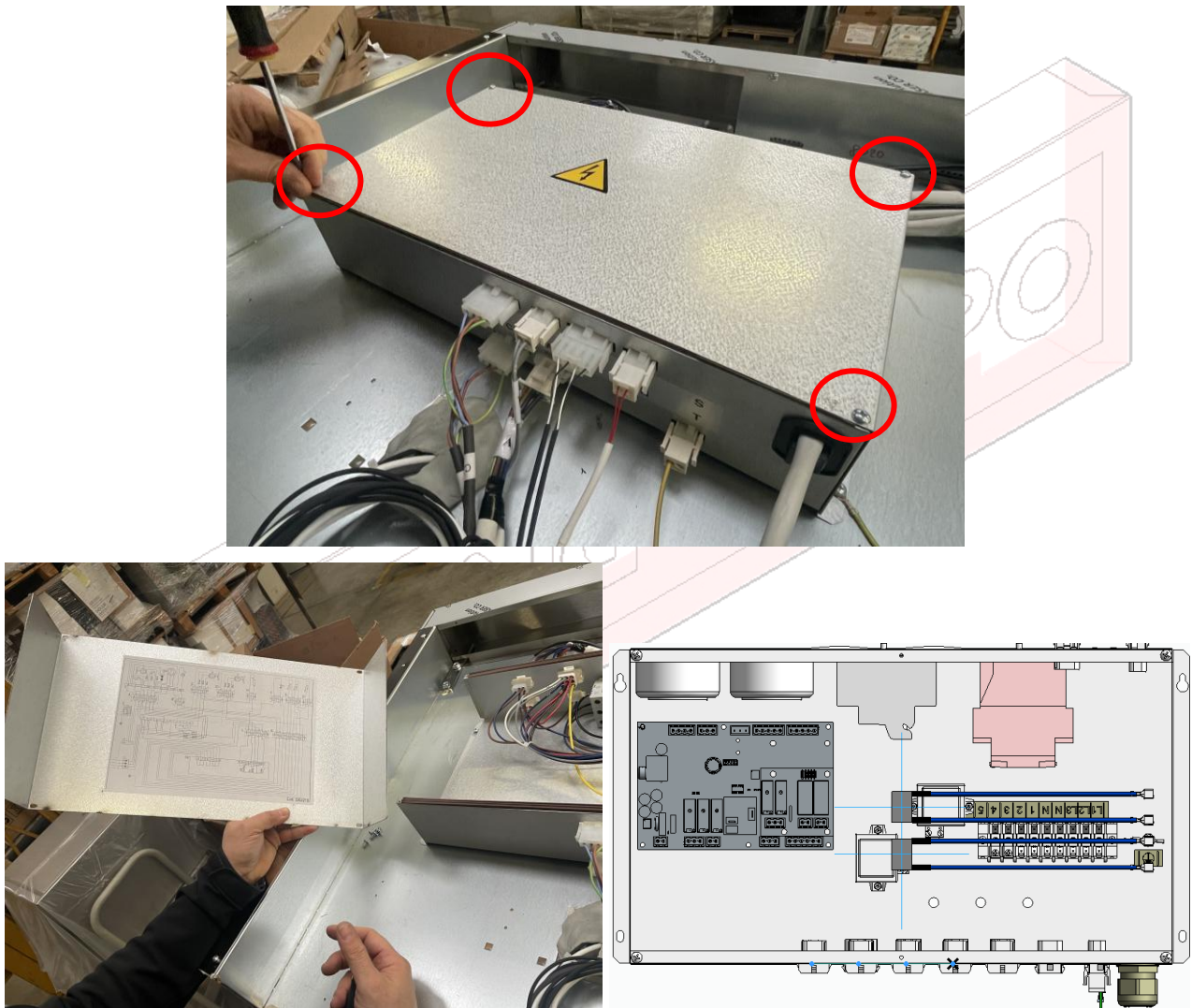

Figure 48



3.9 FUSE MAINTENANCE



Before proceeding with maintenance operations on panel kits, electrical panels or any other electronic or electromechanical component, use insulating personal protective equipment (gloves) and discharge any residual current to avoid the risk of electric shock. If possible, it is advisable to operate with the panel kit placed on an earthed antistatic mat and wearing an ESD bracelet.

- I. Open the fuse holder.

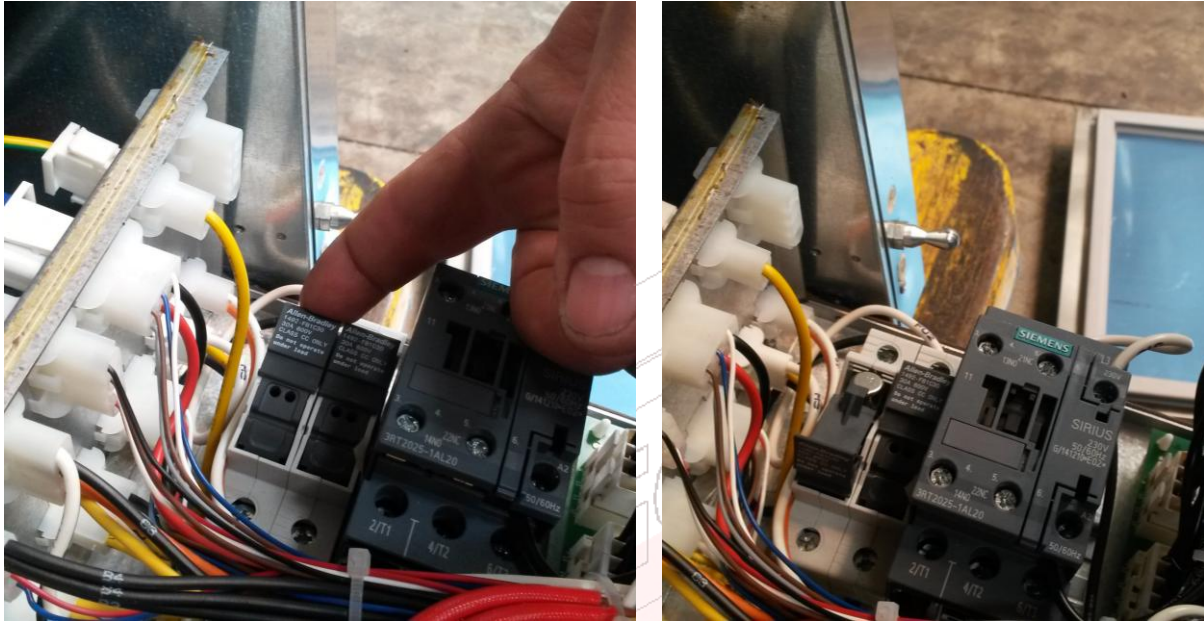

Figure 49

- II. Remove the fuse to be replaced.



Figure 50



3.10 CONTACTOR MAINTENANCE



Before proceeding with maintenance operations on panel kits, electrical panels or any other electronic or electromechanical component, use insulating personal protective equipment (gloves) and discharge any residual current to avoid the risk of electric shock. If possible, it is advisable to operate with the panel kit placed on an earthed antistatic mat and wearing an ESD bracelet.

- I. Loosen screws in order to disconnect contactor electrical connections.

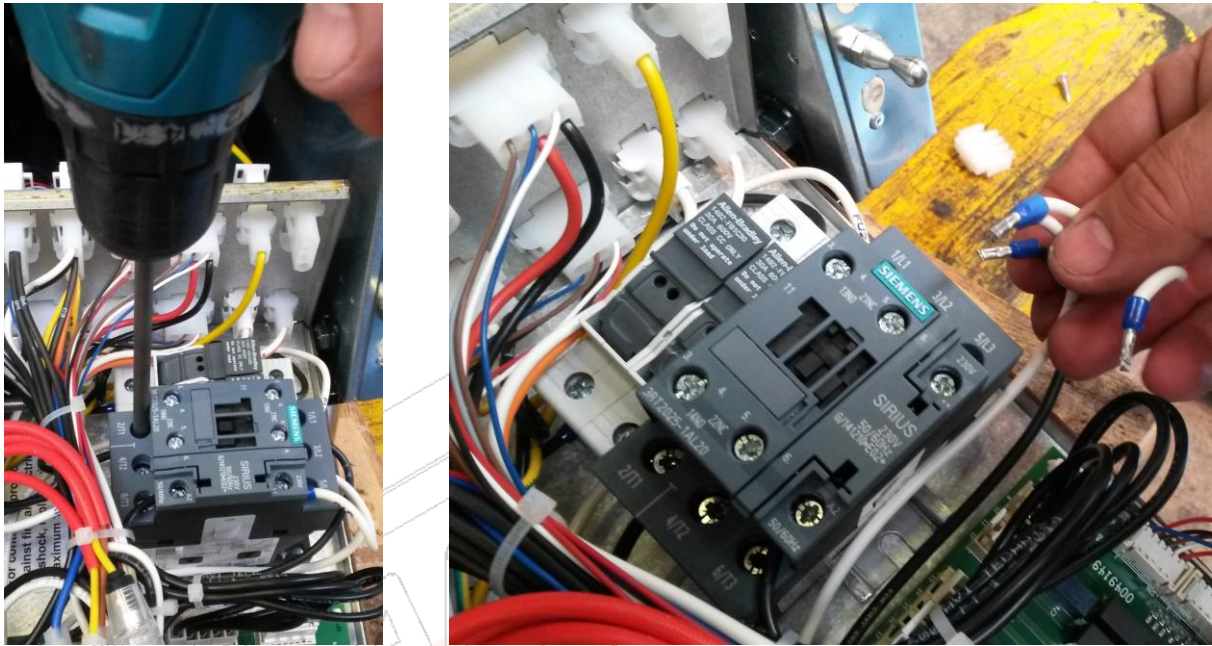

Figure 51

- II. To remove the contactor, push forward and then lift the component as indicated in the figure.

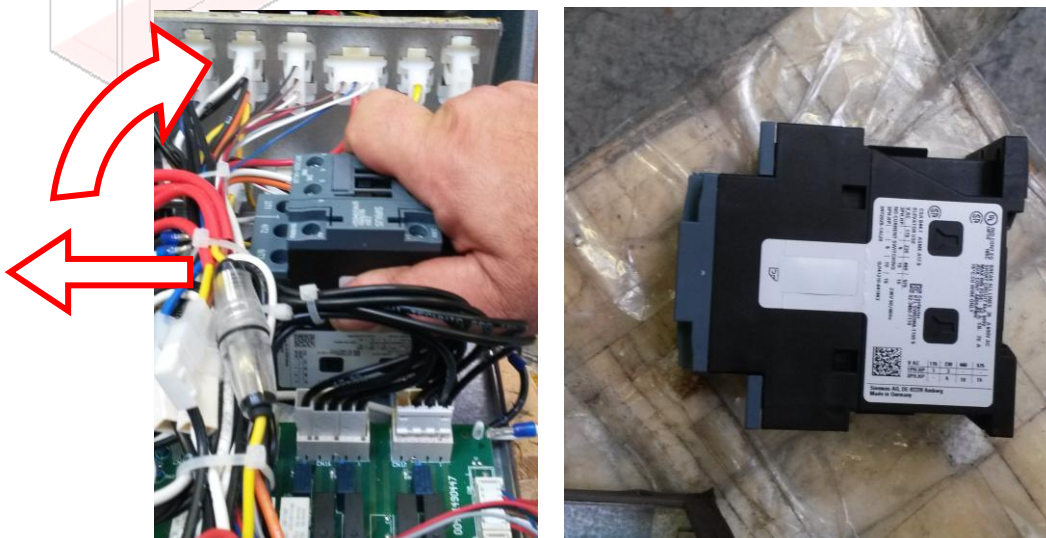

Figure 52



3.11 REMOVING THE MATE-N-LOK FEMALE CONNECTOR



Before proceeding with maintenance operations on panel kits, electrical panels or any other electronic or electromechanical component, use insulating personal protective equipment (gloves) and discharge any residual current to avoid the risk of electric shock. If possible, it is advisable to operate with the panel kit placed on an earthed antistatic mat and wearing an ESD bracelet.

- I. Use a screwdriver on the fastening fins on both sides to remove the Mate-n-lok connector from the electrical panel.
- II. Remove the connector from inside the panel.



Figure 53



3.12 EVAPORATOR FAN MAINTENANCE

SBU15GL...SBU20GL...-SBU20GT...

- I. Remove any shelf supports or grilles present.



Figure 54

- II. Unscrew the two fan support plate screws.



Figure 55



- III. Rotate the motor fan support plate to access the evaporator and the motor fan.

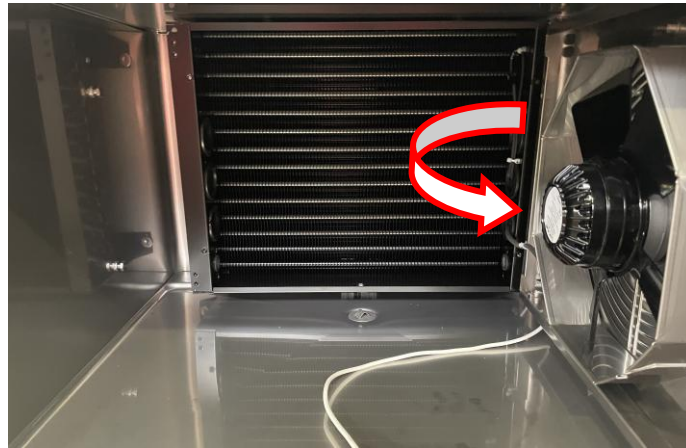

Figure 56

- IV. Separate the motor fan plug cable.
V. Using a hexagonal spanner, unscrew the screws shown in the figure and remove the grille-motor fan assembly.

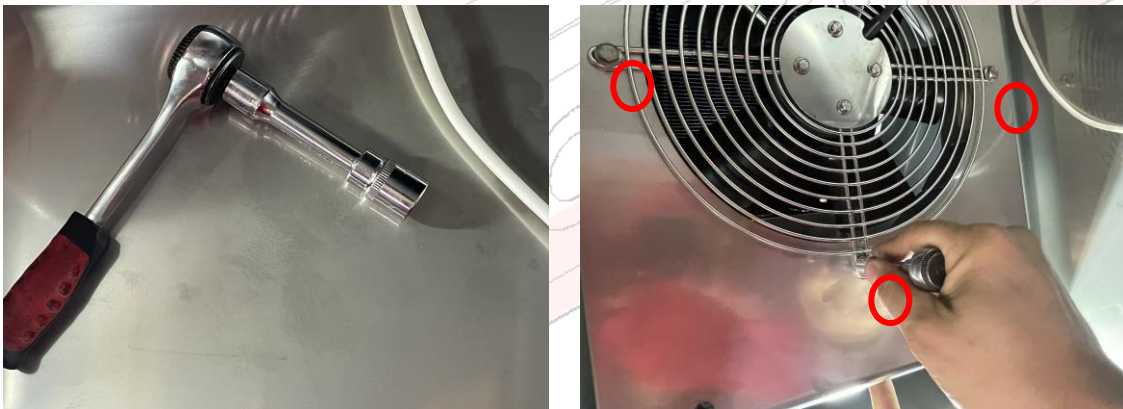

Figure 57

- VI. The replacement motor fan will be supplied with the grille and the cable ready to be reassembled.

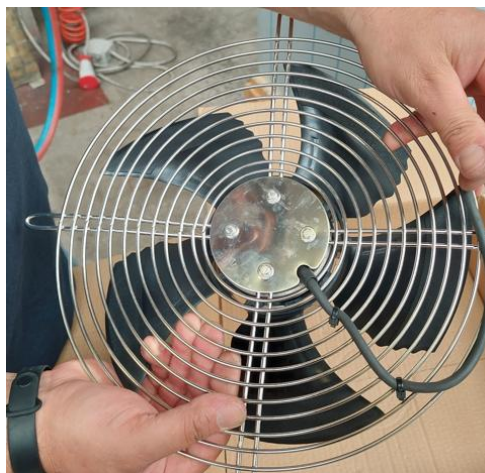

Figure 58

**SBU40GT-SBU65GT**

- VII. Models SBU40GT and SBU65GT have a double fan for the evaporator but the procedure for their removal is the same with respect to models SBU15GL... and SBU20G....

**Figure 59**



3.	MAINTENANCE: PART 2	56
3.13	NEEDLE PROBE AND CHAMBER/EVAPORATOR PROBE MAINTENANCE .	56
3.14	EVAPORATOR COIL MAINTENANCE	58
3.15	PRESSURE SWITCH MAINTENANCE	64
3.16	COMPRESSOR ELECTRICAL BOX MAINTENANCE	66
3.17	LIQUID LINE SOLENOID VALVE MAINTENANCE.....	67
3.18	CONDENSER FAN MAINTENANCE.....	70
3.19	CONDENSING COIL MAINTENANCE	72
3.20	COMPRESSOR MAINTENANCE.....	76
3.21	THERMOSTATIC VALVE MAINTENANCE.....	78
3.22	CHECKING FOR LEAKS/LOSSES AND REFRIGERANT CHARGE.....	83
3.23	SPECIFIC EQUIPMENT AND TOOLS.....	85
3.24	IDENTIFYING MICRO LEAKS.....	86
3.25	FEET MAINTENANCE.....	89

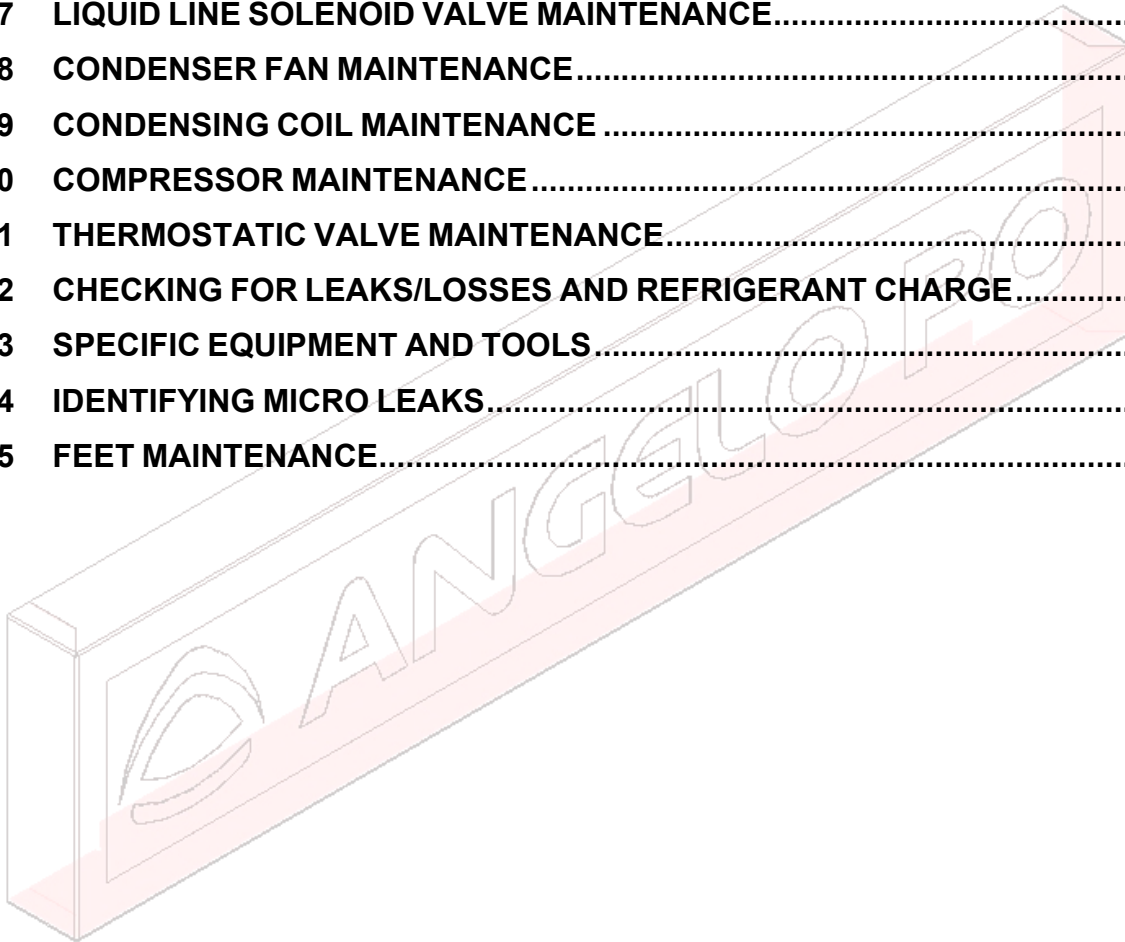

3. MAINTENANCE: PART 2

3.13 NEEDLE PROBE AND CHAMBER/EVAPORATOR PROBE MAINTENANCE

NEEDLE PROBE

The monopoint needle probe is connected directly to the electrical panel with its cable passing through a hole at the base of the evaporator in models SBU15GL... and SBU20G... (figure 1) and above the evaporator in models SBU40GT and SBU65GT (figure 2).



Figure 1

- I. Repeat the operations described in the previous sections according to the model to access the panel kit.
- II. Disconnect the G terminal (needle probe).
- III. Disconnect the Mate-n-lock as described in the previous sections.
- IV. Remove the cable and the tips of the needle probe to be replaced.
- V. Pass the needle probe cable through the hole and re-couple the mate-n-lock connection.
- VI. Connect the new mate-n-lock connector to the corresponding mate-n-lock G connector on the panel.

CHAMBER AND EVAPORATOR TEMPERATURE PROBES

- VII. Open the evaporator protection as described in paragraph 3.13 sections I-III.
- VIII. Open the fins to access the defrost/evaporator probe.

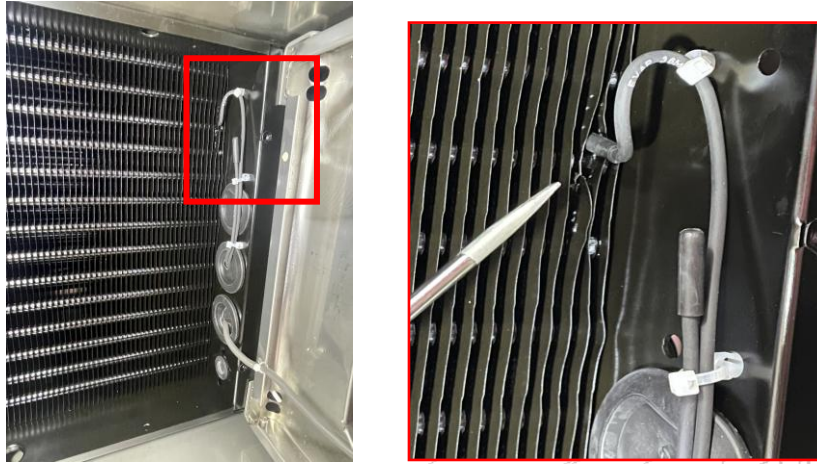

Figure 2

- IX. Cut the grips to free the cables of the two probes.
- X. Repeat the operations described in paragraphs 3.6 sections I, IV or VIII depending on the model to access the panel kit and disconnect the “E” terminal. Remove the tips from the mate-n-lok connection of the probe that needs replacing (Note: consult the wiring diagram for your model, referring to paragraph 1.4).
- XI. The new probes will be provided with the mate-n-lok terminal already wired. Connect the terminal to the electrical panel and insert the new sensors in the refrigerated compartment. Restore wiring and grips.

3.14 EVAPORATOR COIL MAINTENANCE

Proceed as follows to replace the evaporator:

- I. Drain the coolant from the circuit using suitable recovery equipment (see figure below).



Figure 3

- II. Operate in the refrigerated compartment as described in the previous sections.
- III. Disconnect the fan cable from the panel kit.
- IV. Disassemble the screws indicated in the figure in order to disassemble and remove the fan from its panel.



Figure 4

- V. Remove (if present, depending on the model) the support shown in the figure to facilitate subsequent removal of the evaporator. The support can be either at the bottom or at the top.



Figure 5

- VI. Remove the needle probe, the chamber and evaporator temperature probes as described in section 3.14.
- VII. Remove the protective grille from the motor compartment on models SBU15GL... and SBU20G....



Figure 5

- VIII. Unscrew the 4 screws fastening the evaporator to the structure with a socket wrench.

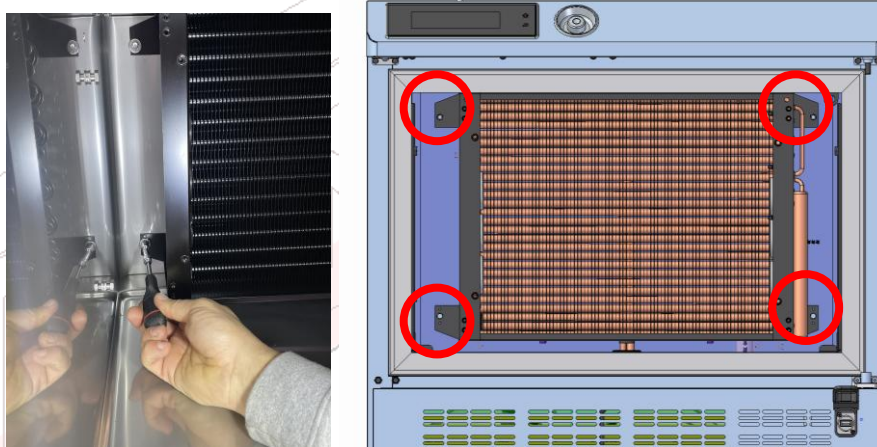

Figure 6

- IX. Remove the evaporator.



Figure 7

- X. For models SBU40GT and SBU65GT, remove the rear panel to access the area where the piping passes through the structure and remove the sealing paste that closes the passageways.

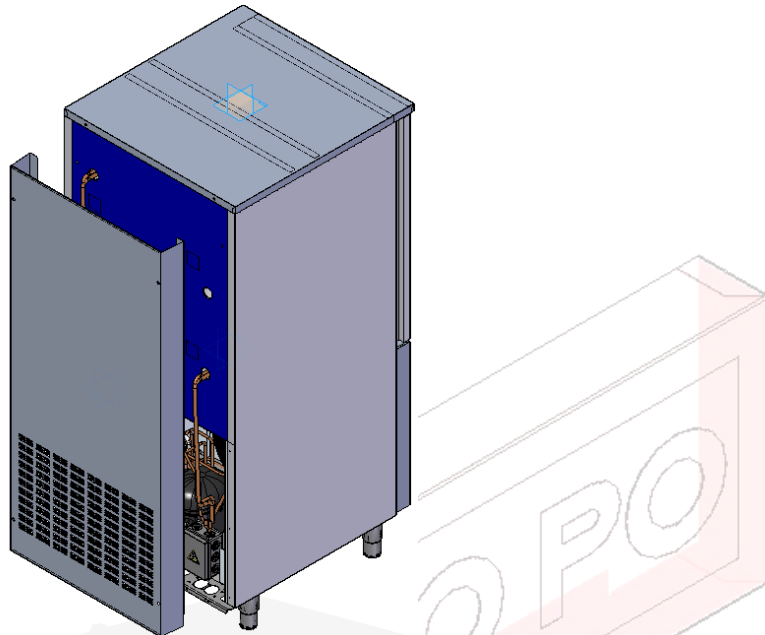

Figure 8

- XI. Disassemble the grille/tub support elements and then the fan guard by means of the support brackets, first removing the upper one and then the lower one.

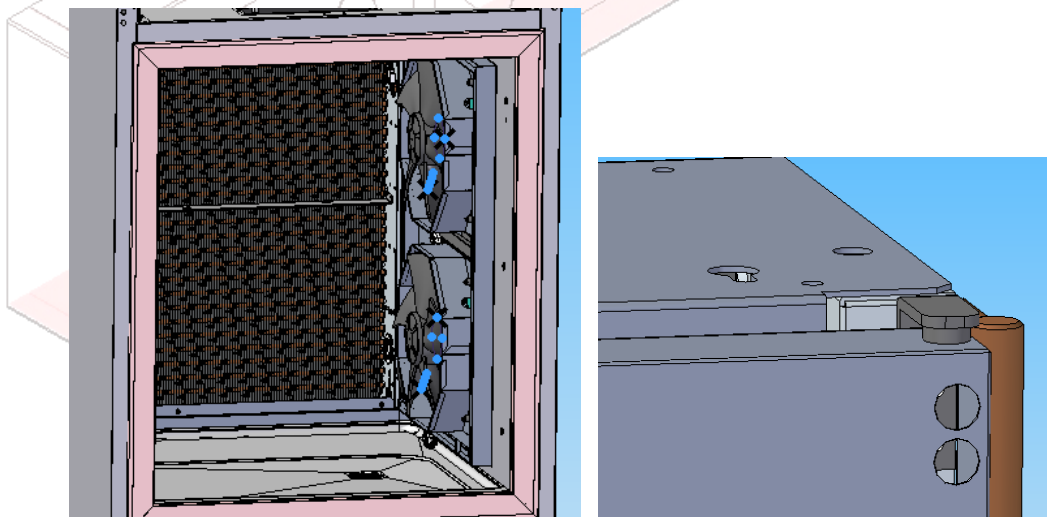

Figure 9

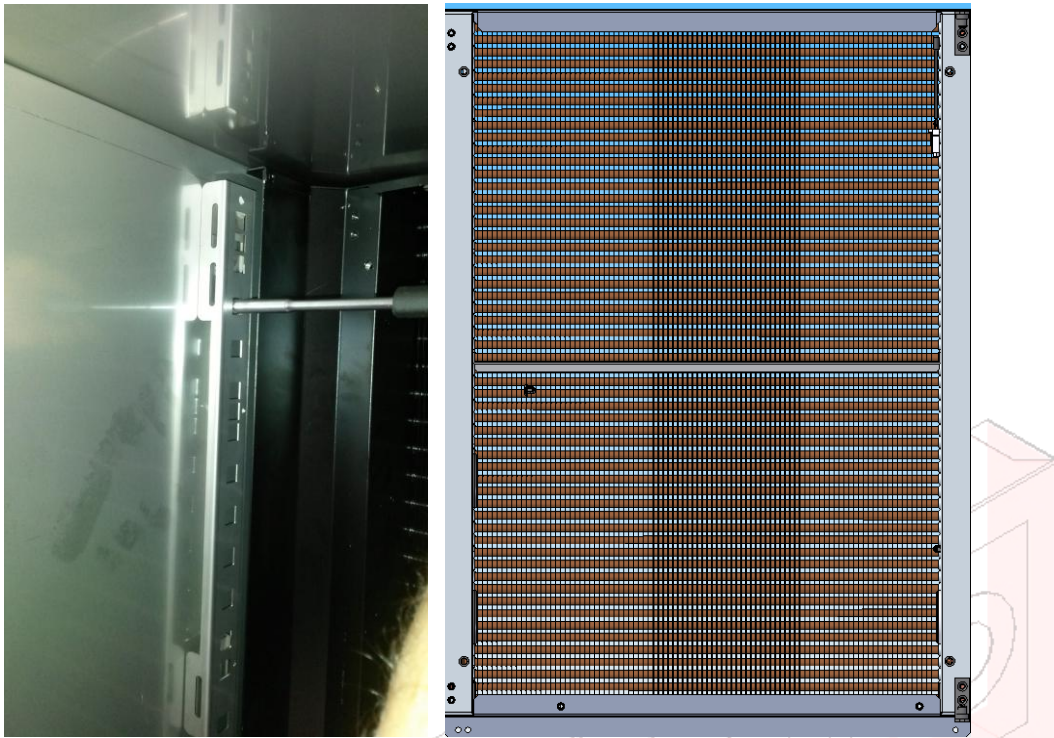

Figure 10

XII. Unsolder the evaporator pipes by means of the rear of the machine.



Figure 11

XIII. Unscrew (without removing) the top fastening screws on the evaporator. The evaporator has slots which allow for removal without completely removing screws. To remove the evaporator, move it in the direction indicated by the arrows.

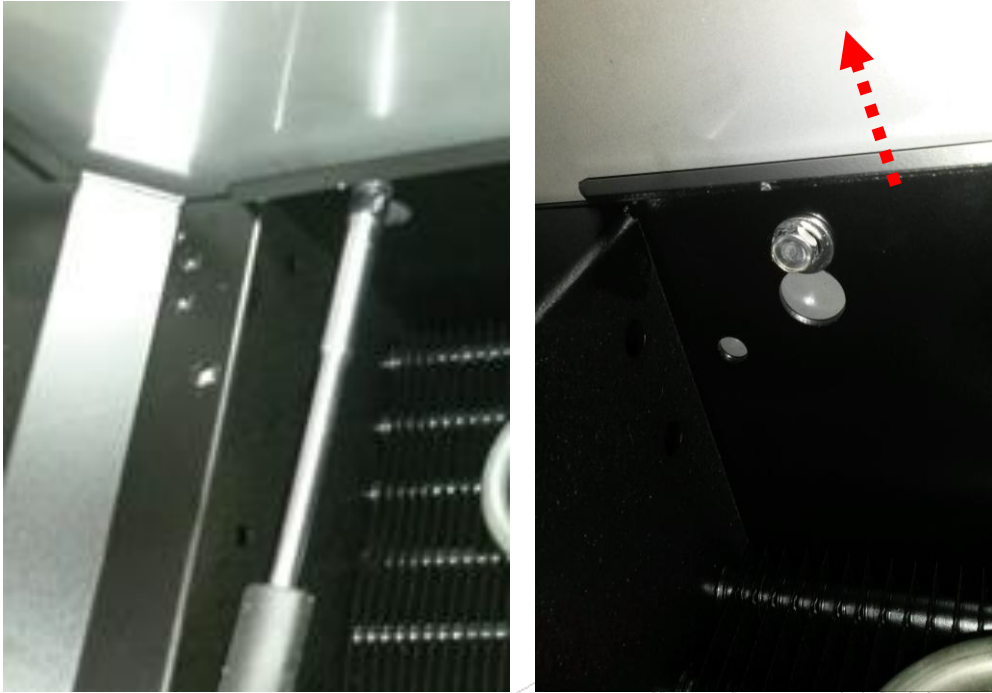

Figure 12

- XIV. Unscrew the fastening screws at the bottom of the evaporator.



Figure 13

- XV. Maintain the cables at the bottom of the machine so that they can be removed with the evaporator. Some mate-n-lok connectors are able to pass inside the duct without being dismantled.
- XVI. Remove the evaporator and arrange it on the bench.
- XVII. Cut the grips fastening the insulating sheath and unsolder the two evaporator tubes in the area shown in the figure.

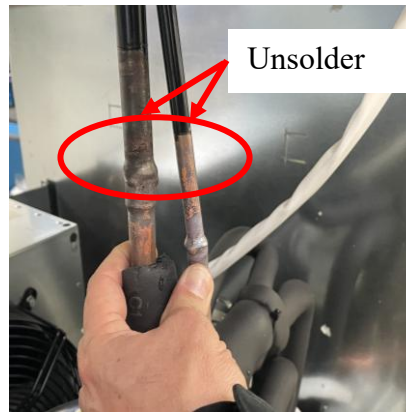
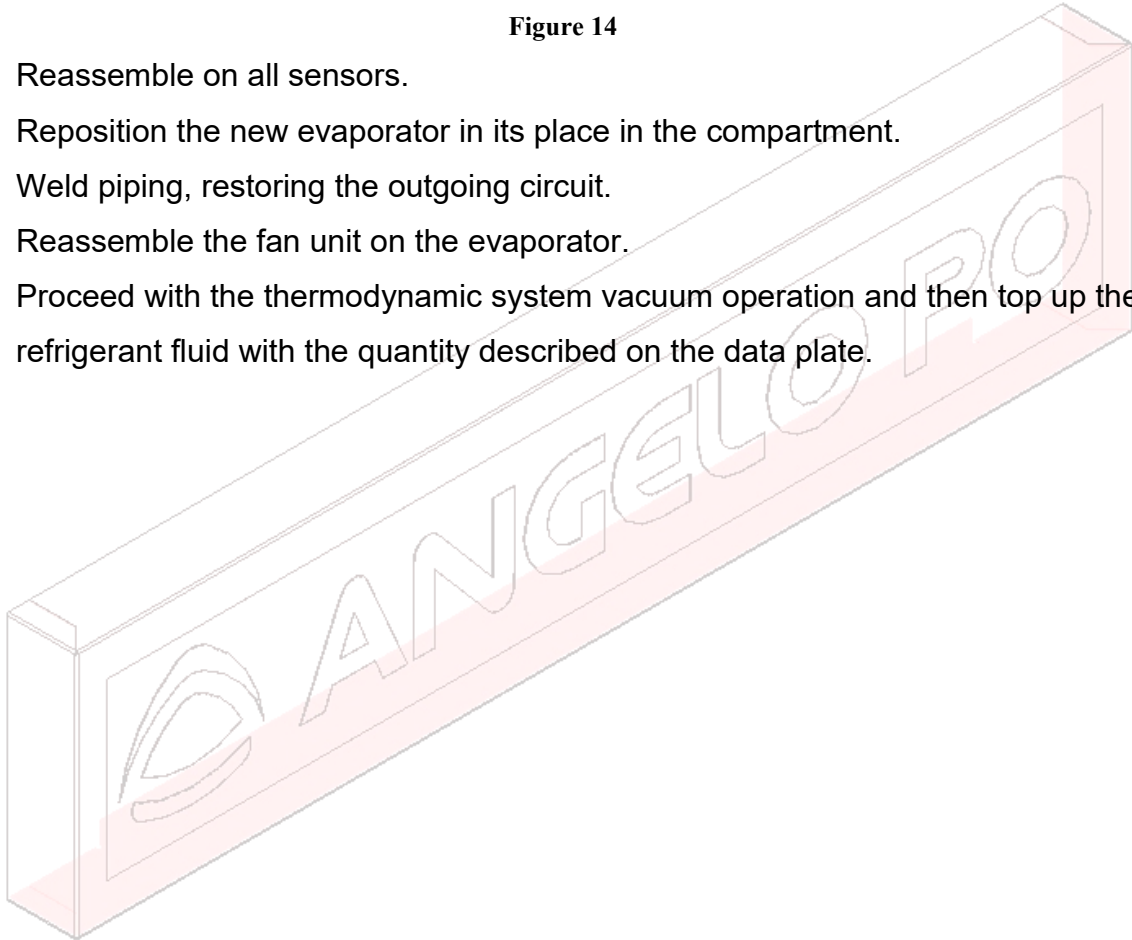

Figure 14

- XVIII. Reassemble on all sensors.
- XIX. Reposition the new evaporator in its place in the compartment.
- XX. Weld piping, restoring the outgoing circuit.
- XXI. Reassemble the fan unit on the evaporator.
- XXII. Proceed with the thermodynamic system vacuum operation and then top up the refrigerant fluid with the quantity described on the data plate.



3.15 PRESSURE SWITCH MAINTENANCE

Models SBU15GL... and SBU20G... do not have this component.

I. Condenser pressure switch position

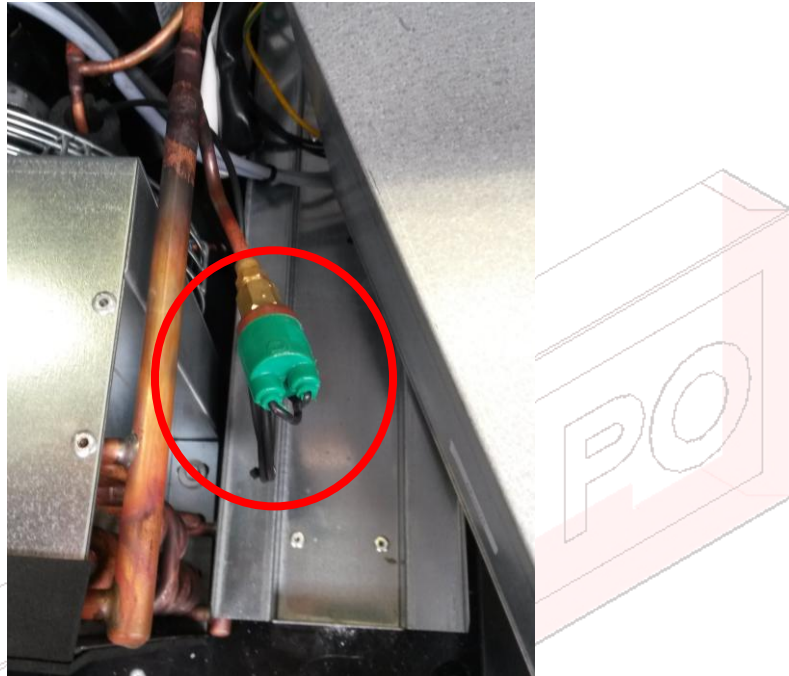

Figure 15

II. The pressure switch is tightened onto the Schrader valve on the pipe; the valve is equipped with a needle preventing coolant from leaking when replacing components.

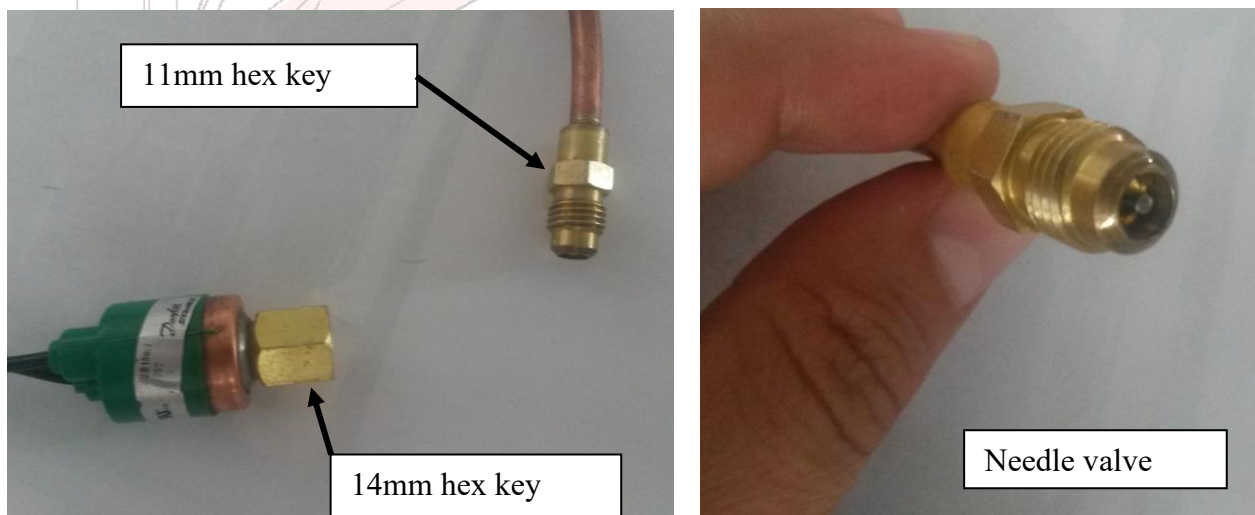

Figure 16

- III. To remove the pressure switch, use two spanners to avoid twisting it during maintenance. Reduce the tightening force by acting slightly on the 14 hexagon, making sure that the counter-port is held in place using the 11 spanner.

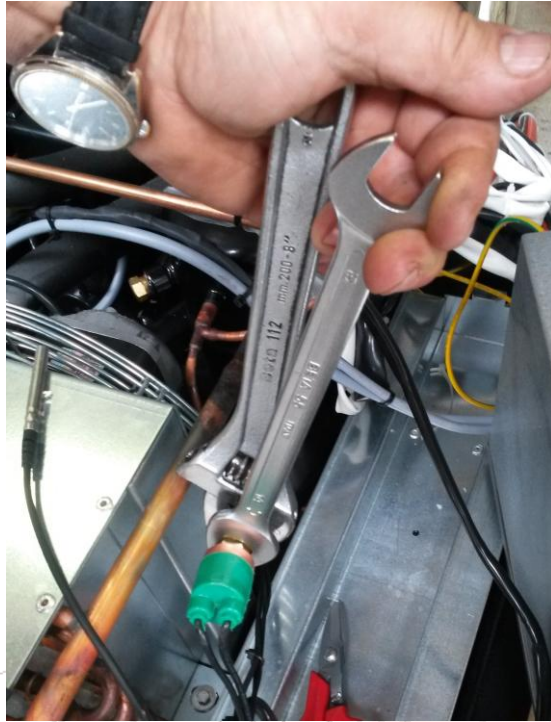

Figure 17

- IV. **Once loosened, quickly unscrew the pressure switch by hand to minimise any coolant leaks.**



- V. The condenser probe and the pressure switch are wired in the same terminal "B". Disconnect the terminal from the electrical panel and remove components.



Figure 18

3.16 COMPRESSOR ELECTRICAL BOX MAINTENANCE

- I. Remove the rear grille to access the compressor electrical box.

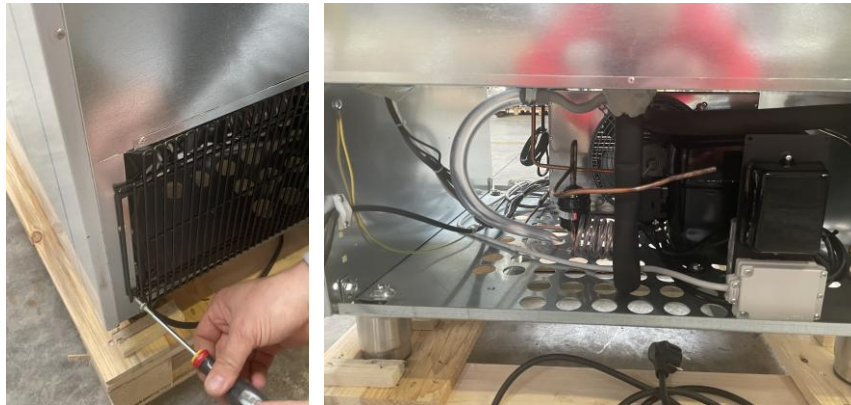

Figure 19

- II. Unscrew the screws at the base of the electrical box.
- III. Cut grips and remove the electrical box.
- IV. Unscrew the screw to access contacts inside the box.

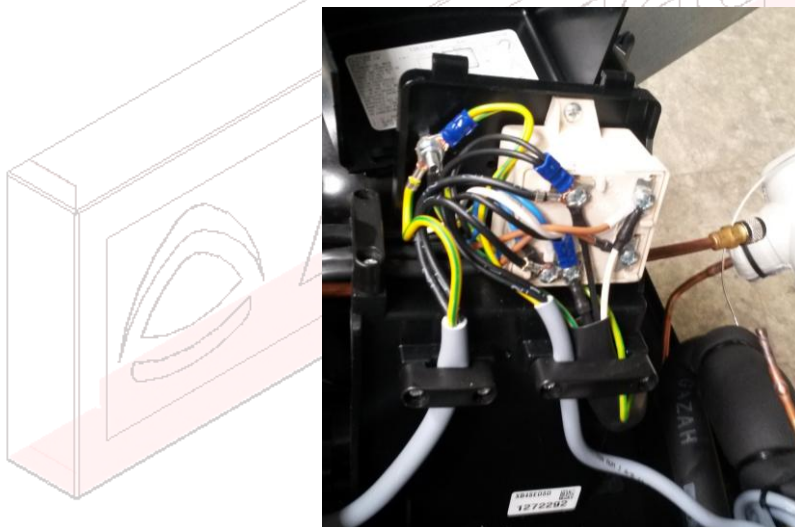

Figure 20

- V. Perform electrical connection maintenance as needed.

3.17 LIQUID LINE SOLENOID VALVE MAINTENANCE

DO NOT POWER THE COIL ONCE REMOVED FROM THE SOLENOID VALVE BODY



Note: this component is not present in models SBU15GL....

Proceed as follows to perform solenoid valve maintenance:

- I. Remove the motor compartment protective grille as described in section 3.15 paragraph VI.
- II. Unscrew the screw shown in the figure and remove the solenoid valve connector.

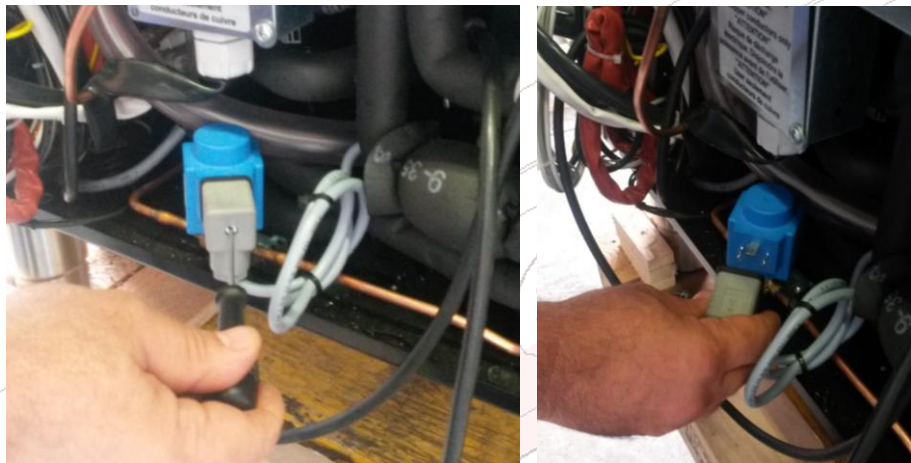

Figure 21

- III. Remove the actuator, levering on the valve body with a screwdriver as shown in the figure.

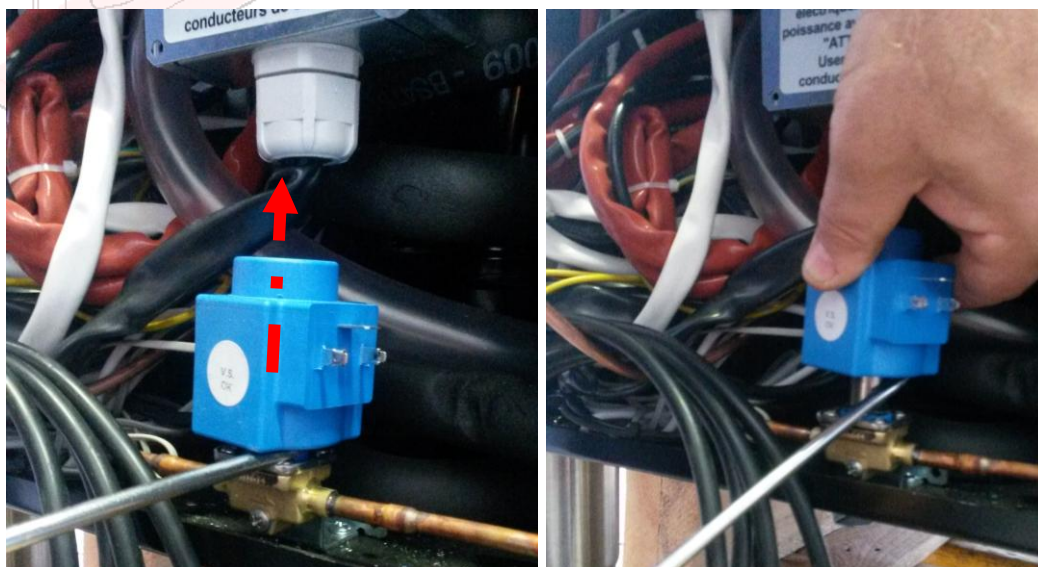

Figure 22

IV. Remove and replace the valve actuator.



Figure 23

V. If necessary, replace the valve body discharging coolant inside the circuit and unsoldering piping at the points indicated in the figure.



Figure 24

VI. Unscrew the fastening screw and replace the valve body.



Figure 25

- VII. Assemble the new valve, paying attention to the flow direction, and weld piping restoring the circuit.
- VIII. Proceed with the thermodynamic system vacuum operation and then top up the refrigerant fluid with the quantity described on the data plate.

3.18 CONDENSER FAN MAINTENANCE

SBU15GL...-SBU20GL...-SBU20GT...

- I. Tilt the structure to access the condenser fans: unscrew two of the four screws (the front ones) securing the structure to the base and loosen the other two (the rear ones) so you can use them as a pivot to tilt the structure. Use a support to keep the structure tilted.



Figure 26

- II. Unscrew the 4 screws securing the fan.

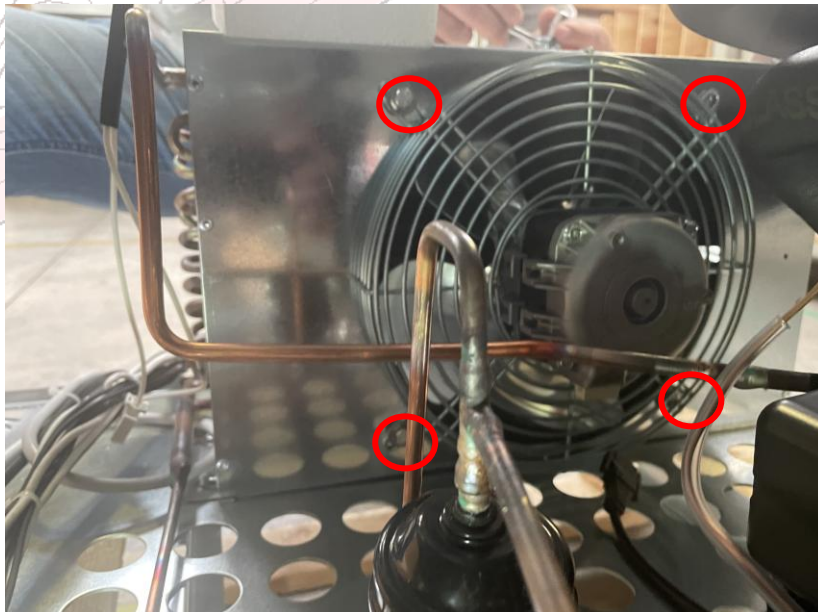

Figure 27

III. Disconnect the cable and cut any electrical cable grips. Remove the fan.



Figure 28

SBU40GT-SBU65GT

IV. Remove the rear panel protecting the motor unit.

V. Unscrew the 4 screws securing the fan.

VI. Open the electrical box in the motor compartment to disconnect the motor fan cable (see the wiring diagram on the protective plate) and remove the motor fan.



Figure 29

3.19 CONDENSING COIL MAINTENANCE

Proceed as follows to replace the condenser:

- I. Drain coolant from the thermodynamic circuit, collecting it with suitable equipment.
- II. Overturn the structure (see section 3.15).
- III. Remove the condenser protective plate and the support plate for the electrical panel by removing the rivets securing it to the structure with a drill.

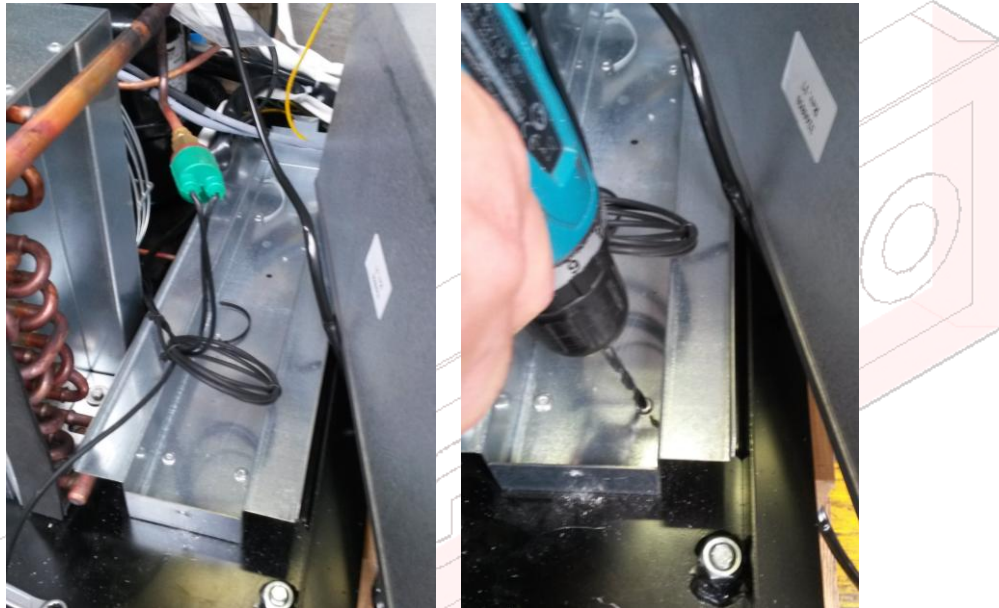

Figure 30

- IV. After having drained coolant, unsolder condenser piping in the area indicated in the figure.

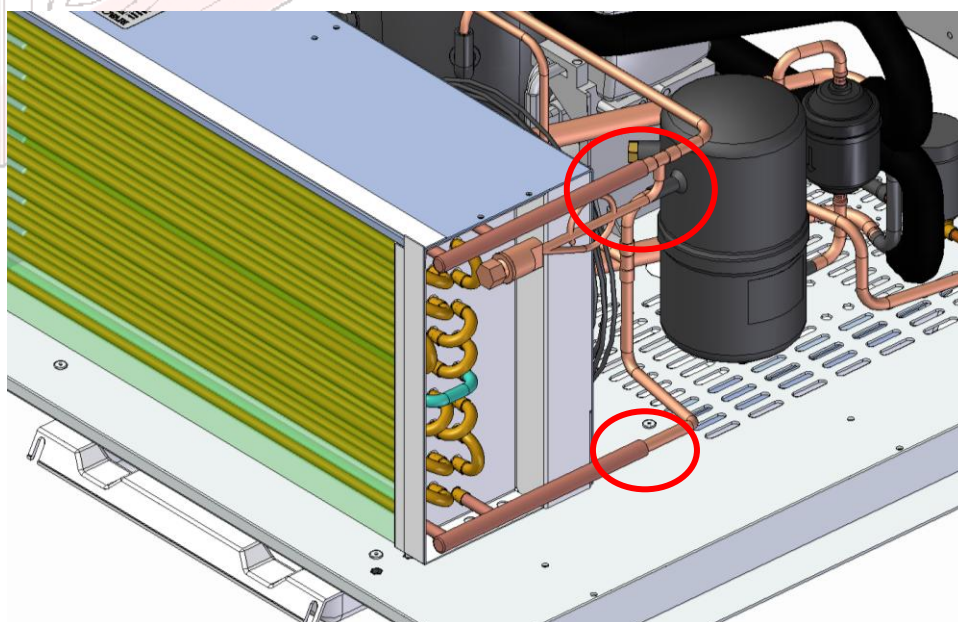

Figure 31

- V. Unscrew the 4 screws fastening the condenser to the base plate with a jointed socket wrench.

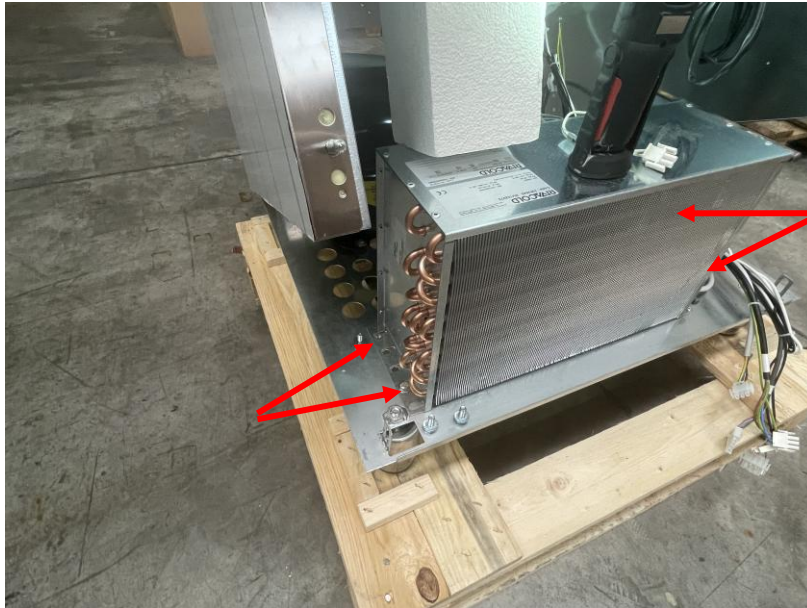

Figure 32

- VI. Remove the condenser.



Figure 33

- VII. Secure the new condenser to the base plate.
VIII. Weld piping, restoring the thermodynamic circuit.
IX. Proceed with the thermodynamic system vacuum operation and then top up the refrigerant fluid with the quantity described on the data plate.

SBU15GLE

- X. Remove the condenser protection panel (see section 3.3 part I) and disconnect all the mate-n-loks from the panel kit in order to operate.
- XI. Overturn the structure (see section 3.15).
- XII. Carry out the same procedures described from point IV to point IX.

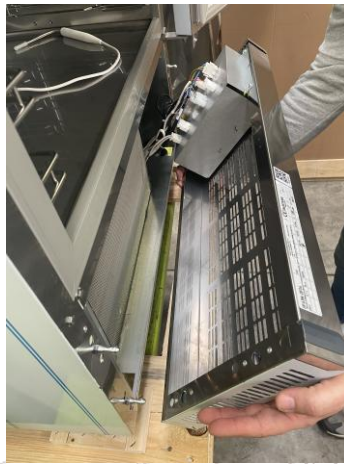

Figure 34

SBU40GT-SBU65GT

- XIII. Remove the condenser protective panel.



Figure 35

XIV. Dismantle the plates on the sides of the condenser, removing the rivets with a drill.

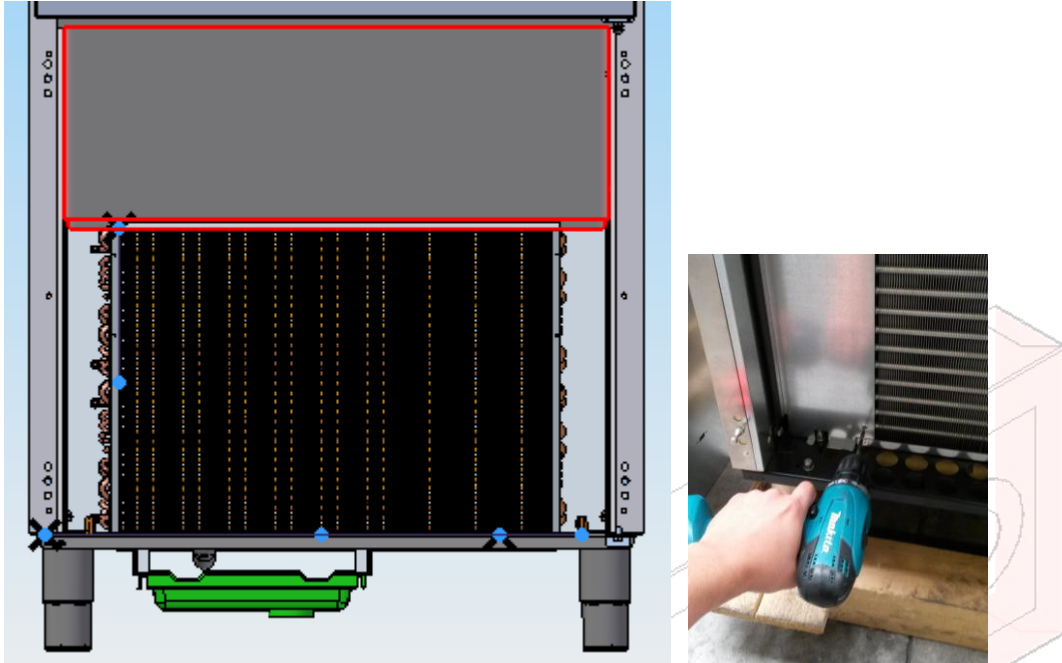
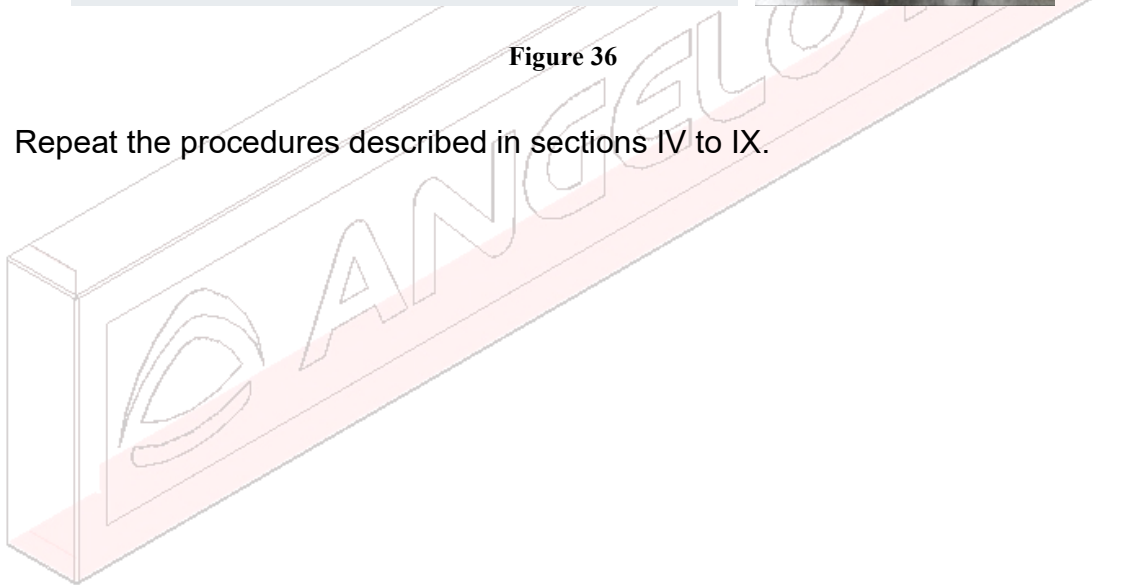

Figure 36

XV. Repeat the procedures described in sections IV to IX.



3.20 COMPRESSOR MAINTENANCE

Proceed as follows to replace the compressor:

- I. Drain the coolant from the thermodynamic circuit, collecting it with suitable equipment
- II. Overturn the structure (see section 3.19).
- III. Unsolder compressor piping in the area indicated in the figure.



Figure 37

- IV. Disconnect the electrical box from the panel.
- V. Unscrew the 4 screws fastening the compressor to the base.

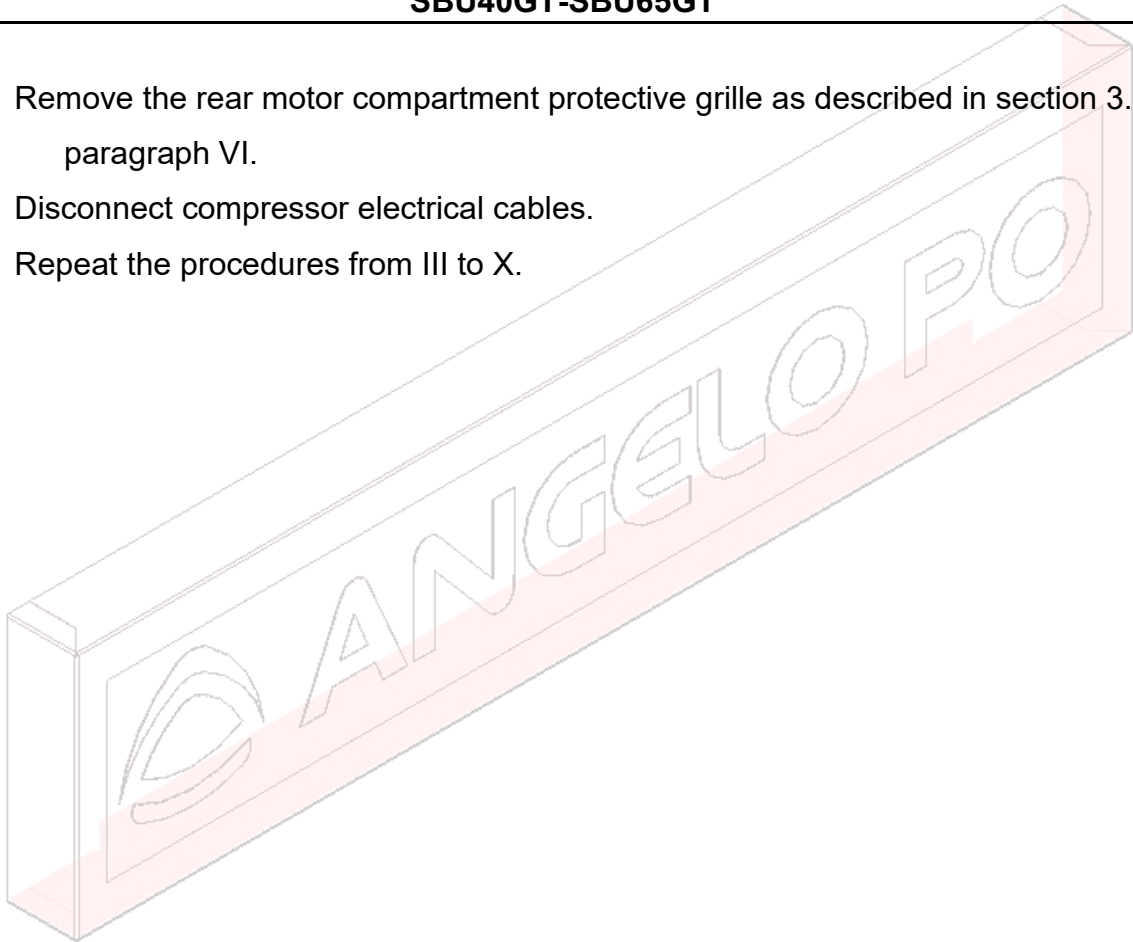

Figure 38

- VI. Remove the compressor and its electrical box.
- VII. Position the new compressor and secure it to the base.
- VIII. Weld piping, correctly restoring the thermodynamic circuit.
- IX. Restore electrical connections.
- X. Fill coolant and verify the absence of any circuit leaks.

SBU40GT-SBU65GT

- XI. Remove the rear motor compartment protective grille as described in section 3.15 paragraph VI.
- XII. Disconnect compressor electrical cables.
- XIII. Repeat the procedures from III to X.



3.21 THERMOSTATIC VALVE MAINTENANCE

- I. Remove the protective grille from the motor compartment.



Figure 39

- II. To perform thermostatic valve maintenance, discharge all coolant from the circuit, collecting it with suitable equipment.
- III. Cut the grips to remove the insulation sheath from the thermostatic valve.

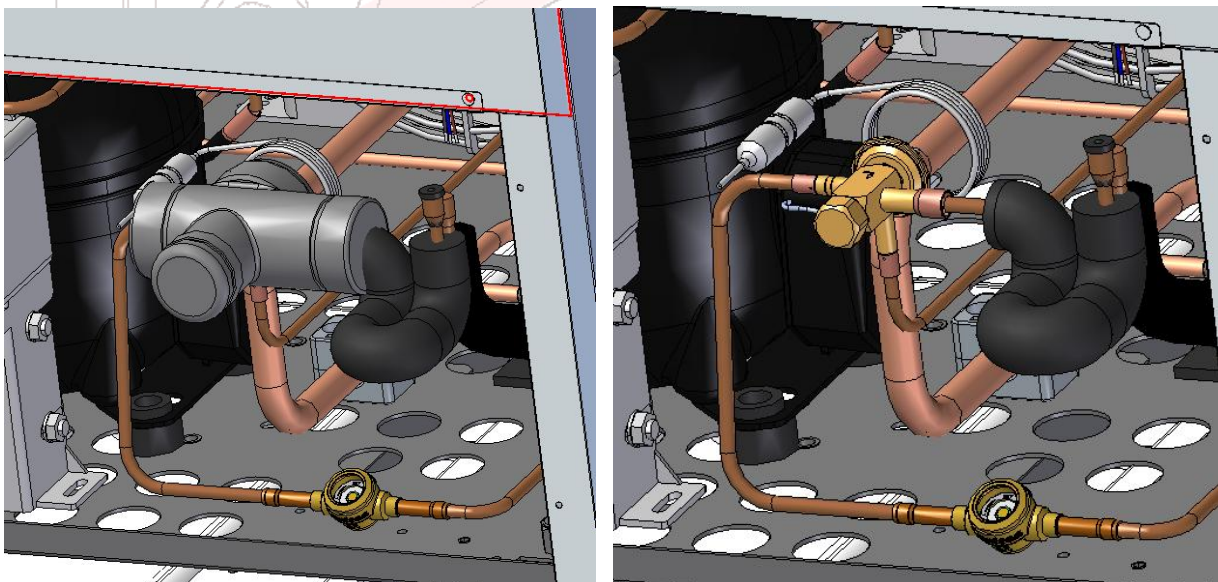

Figure 40

IV. Cut the grips to remove the insulation sheath from the bulb probe.



Figure 41

V. Unscrew the screw shown in the figure to remove the bulb probe from the terminal.



Figure 42

- VI. If the entire valve block needs to be replaced, unsolder the piping in the area highlighted in the figure.

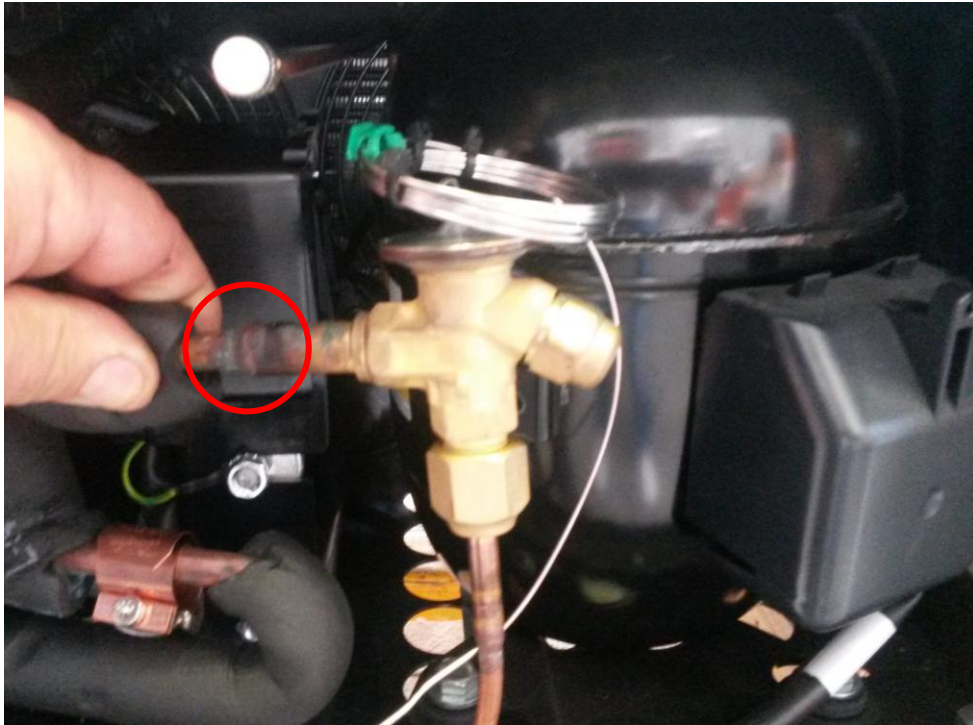

Figure 43

- VII. Unscrew the nut, keeping the valve body blocked as shown in the figure.



Figure 44

VIII. Detail of the thermostatic valve

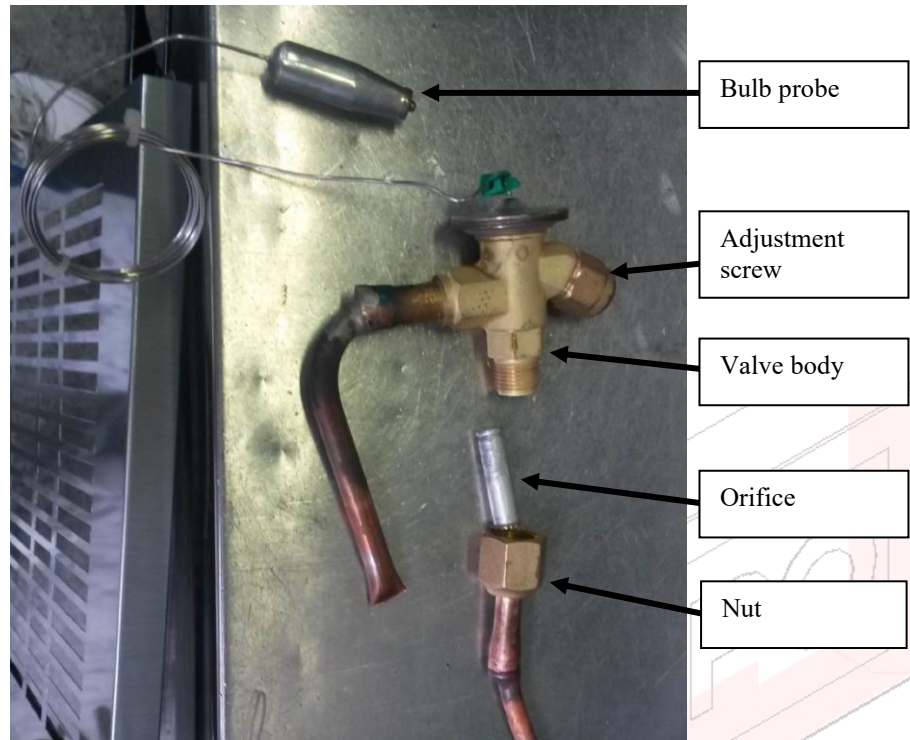

Figure 45

IX. To adjust the valve, unscrew the nut shown in the figure and turn the screw inside it.

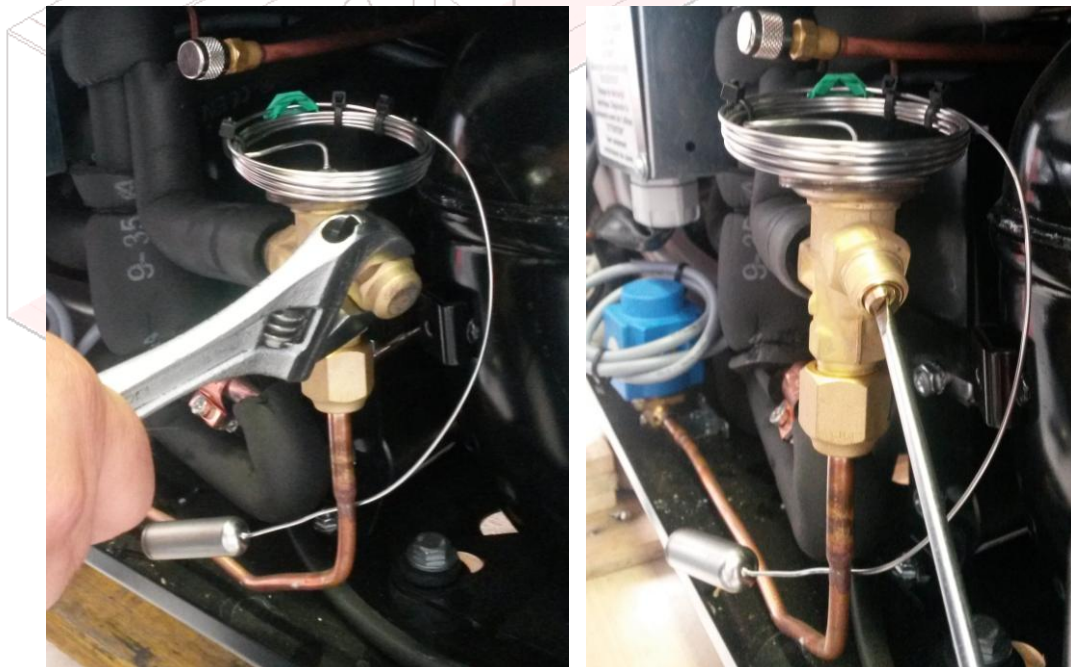
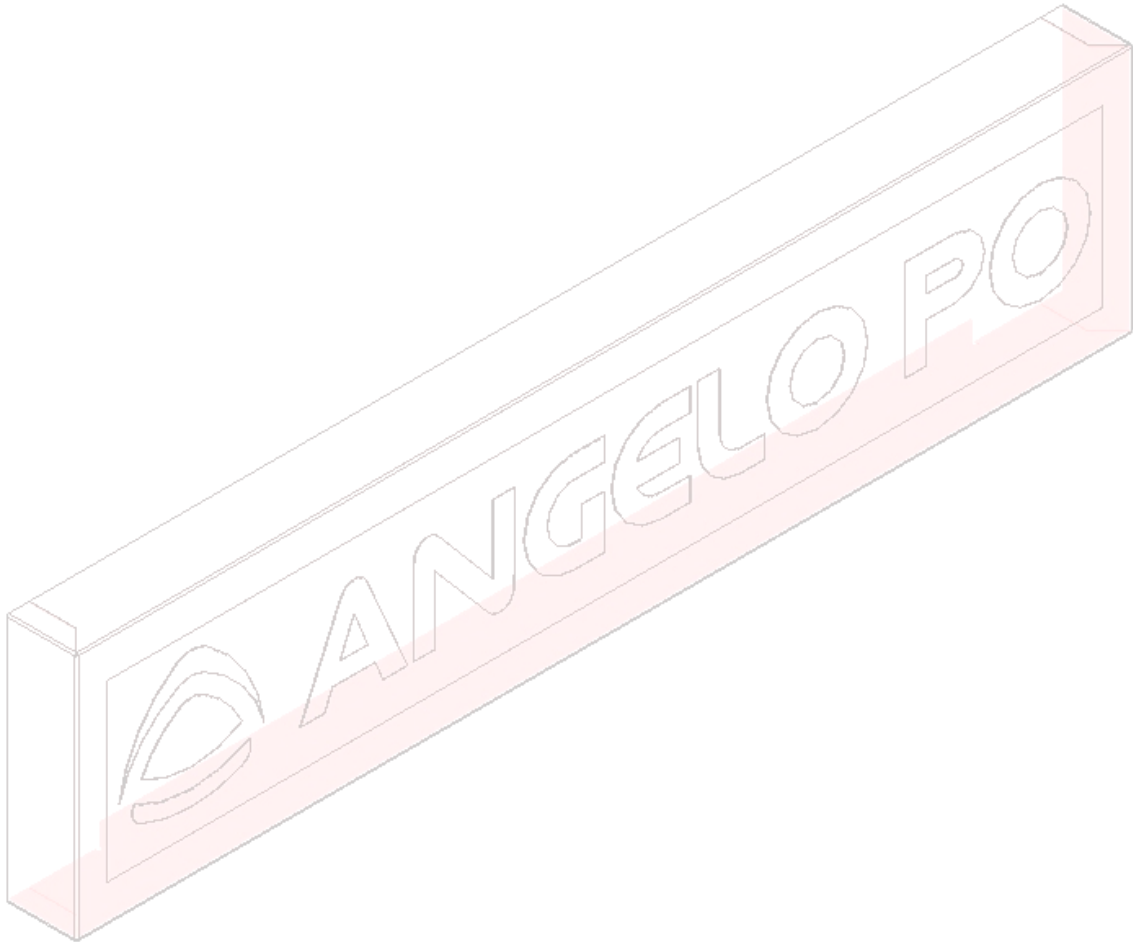

Figure 46

THERMOSTATIC VALVE ADJUSTMENT

Model	Valve adjustment
SBU20GL...	Close 1 turn.
SBU40GT	Close 1 turn.
SBU65GT	Close 1 turn.



3.22 CHECKING FOR LEAKS/LOSSES AND REFRIGERANT CHARGE



Please refer to the HC Guide manual for more information.

The thermodynamic systems on the new blast chillers are filled with R290 hydrocarbon fluid.

WARNING - When working with hydrocarbons it is IMPORTANT that the environments be well ventilated using ATEX ventilation systems – Open the cabinet doors and ventilate.

WARNING – Make sure there are no drains or connections from the room where you are working to any underlying environments.

WARNING - Make sure that there are no ignition points in the work area for a radius of at least 3 metres.

WARNING – Make sure you have the right equipment.

WARNING – Make sure the cabinet and operator are grounded to eliminate the problem of electrostatic charges.

WARNING – Ensure recovery or venting of the refrigerant charge.

WARNING – Technicians using HCs must be qualified to work with flammable refrigerants, have the analytical skills to assess risk, have access to and be familiar with the meaning of the material safety data sheets (MSDS) and act accordingly. Obtain the MSDS (material safety data sheet) for the refrigerant in order to be informed of the dangers of the refrigerant as a fluid heavier than air, toxicological information, etc. Obtain the manual for the cabinet.



LIST OF REQUIRED EQUIPMENT	BEWARE OF SOURCES OF IGNITION
Combustible gas leak detector	A spark can come from an electrical source such as
Tools that do not generate sparks	Contactors – Relays
Needle valve – check the condition of the seals	
PPE (personal protective equipment) – specifications in MSDS	Defrosting elements – Wire heating elements – Door switches
Dedicated R-290 manifold pressure gauges	Lamps
Class B dry powder (bicarbonate-sulphate-phosphate) fire extinguisher for flammable liquids – able to lower the upper flammability limit	Electrical sockets – Sources of static electricity
Thermometer / digital meter	Sources of open flame ignition
ATEX vacuum pump	Deep fryers
	Cigarettes – lighters – Gas appliances – Hotplates
	Abrasive tools – Heat guns – Torches

R290 refrigerant is an HC hydrocarbon. It has a significant difference compared to HFC or CHFC fluorocarbon fluids, which must be taken into account for maintenance management, storage, installation, repair and disposal.

Workplaces must be treated equally, with special attention to the aspects of flammability and their consequences. A risk analysis regarding the use of HC refrigerants must be carried out taking into account the above-mentioned aspects. It is essential to carefully consult the equipment manual.

Only technicians trained in the use of flammable refrigerants are authorised to use R290 refrigerant fluid and to maintain the circuits.

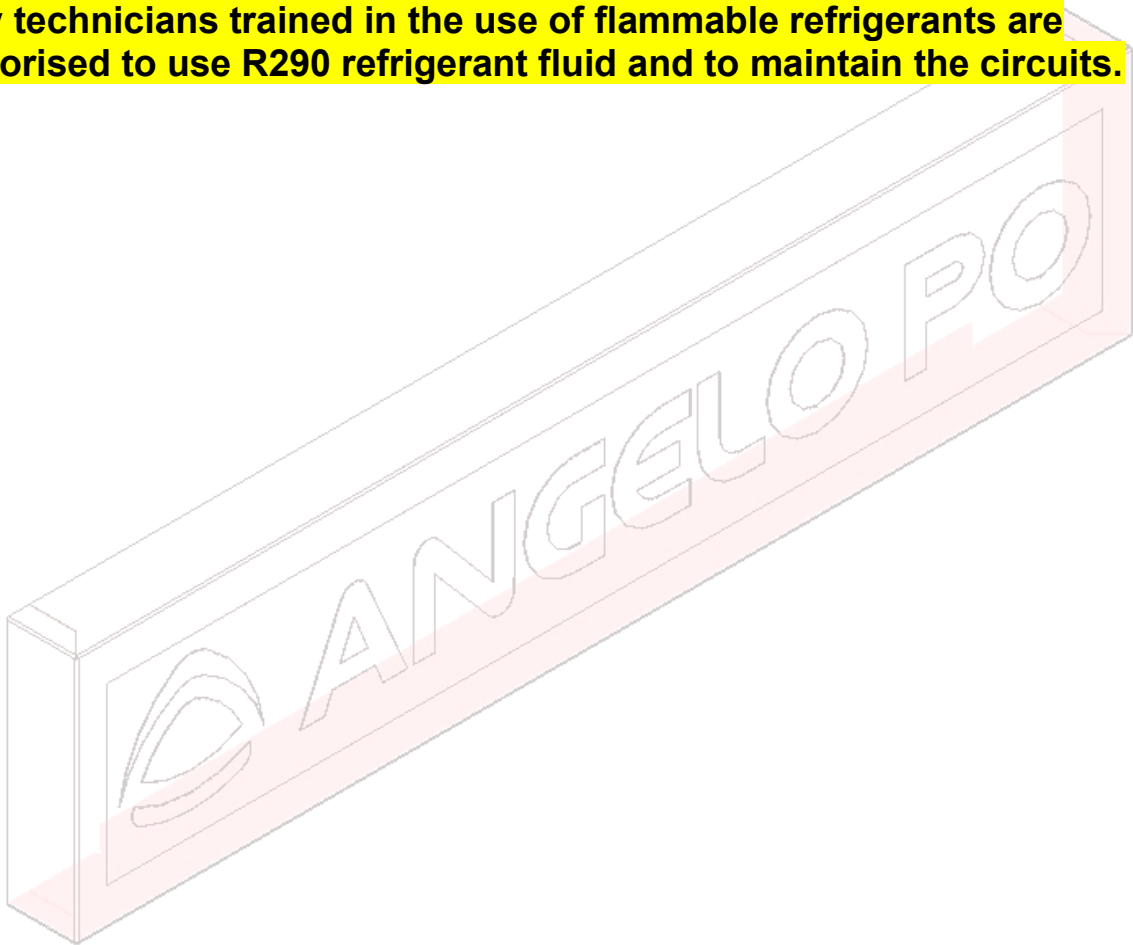

3.23 SPECIFIC EQUIPMENT AND TOOLS



Only use equipment and components certified for danger zones (e.g. vacuum pump, electrical components and parts, original spare parts).

Normal vacuum pumps can be used outside flammable zones but the ON/OFF switch cannot be used, as this is usually the only source of ignition on the pumps. It is however always advisable to use a suitable vacuum pump.

Use leak detectors suitable for HC refrigerants. If the leak cannot be located with an electronic detector, remove the charge, purge and fill with nitrogen and use a spray to detect leaks.



Wear an antistatic bracelet.

Ensure equipotentiality with the machine and the ground.



Use refrigerant recovery machines suitable for HC (they can also be used for HFC).



Recovery machines for HFC cannot be used with HC fluid as they are fitted with potentially dangerous switches, pressure switches and relays.



Recovery units: these must be suitable for HC (nominal pressure, capacity of the check valves, etc.)



Always check local, storage and transport legislation

Internal refrigeration unit volume



The loss of HC from the evaporator inside the cabinet can cause a flammable mixture. The presence of any source of ignition (thermostats, ON/OFF switches, etc.) can cause flames or explosions.

All electrical parts must be encapsulated or comply with fire or explosion prevention regulations.

External refrigeration unit volume



The possibility that a leak of HC outside the cabinet could form an inflammable mixture with air is remote considering the small charge.

Systems integrated into other structures may be more susceptible to this possibility.

3.24 IDENTIFYING MICRO LEAKS

In case of a micro leak in the evaporator or condenser or at a high point in the circuit, a pressure test can be performed using a mixture of 95% nitrogen with 5% traces of hydrogen or helium.



The pre-mixed tracer gas is available on the market.

The advantage of using a gas with trace amounts of helium and hydrogen is that both have small molecules, low speed and molecular mass, so that they can be tested for leaks and fast diffusion.

Preventive actions

1. Have available original spare parts recommended by the manufacturer (for example thermostats – temperature sensors – heating elements – lamps – switches – door micros – etc.)
2. Inform the operators of the operations to be carried out.
3. Carry out a risk assessment of the various activities and adopt countermeasures.
4. Keep people not involved in the operations away.
5. Make sure there are no ignition points within a 3 metre radius.
6. Make sure the work area has sufficient openings and is suitably ventilated.
7. Mark out the work area as a danger zone/area where flammable materials are present; make sure there are no drains or rooms below where refrigerant could collect; if possible, move the cabinet to a specialised workshop or a safe area.
8. Display warning signs (for example No smoking – No open flames).
9. Ventilate the work area using ATEX components.
10. The work area must always be checked with an HC leak detector positioned at a lower level, as HCs have a higher density than air. The sensors must have an audible and visual alarm and activate when the concentration is greater than 20% of the LFL.
11. Use adequate PPE (safety goggles and gloves) and obtain the technical manual and safety data sheet for R290.



12. Adopt suitable measures to ground the devices to eliminate electrostatic charge problems.



Beware of electrostatic charges from capacitors.

13. Avoid working in confined spaces. Work with a partner. Do not use flammable materials such as paper or plastic.



Source:VF

14. Use a suitable extinguisher.



3.25 FEET MAINTENANCE

- I. Raise and/or tilt the machine so that it is not resting on the support feet to be dismantled.
- II. Unscrew the foot with a number ten hex spanner and replace it.

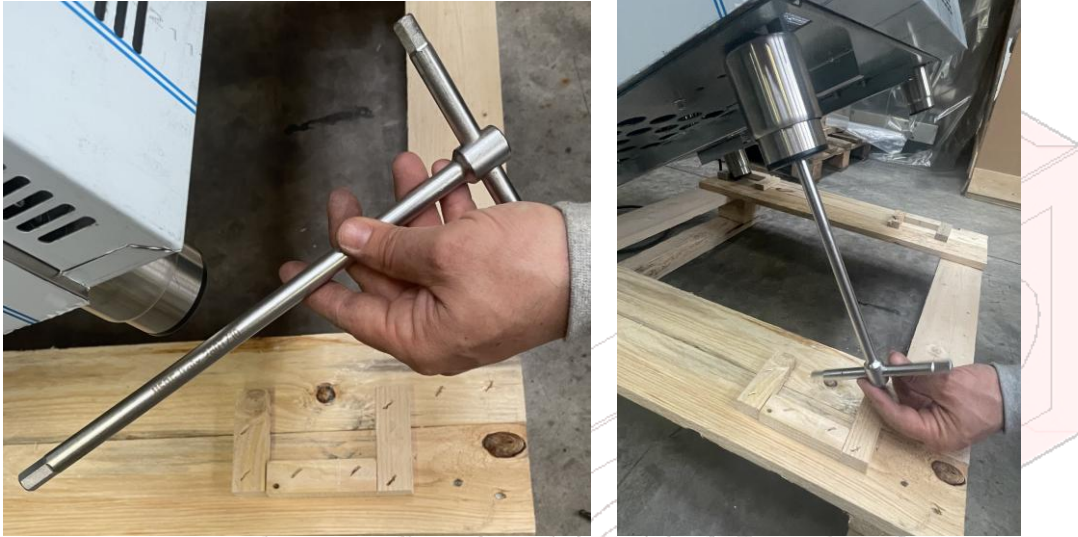

Figure 47

INDEX

4.PARAMETERS – BOARD ALARMS..... 92

 4.1 PARAMETERS.....92

 4.2 ALARMS 100

5.TROUBLESHOOTING 102

 5.1 ALARMS 102

 5.2 OTHER FUNCTIONS 105

 5.3 REFERENCE VALUES 107

4. PARAMETERS – BOARD ALARMS

4.1 PARAMETERS

ACCESS PARAMETERS

- I. To access the parameter map, press the “UP” and “DOWN” buttons simultaneously until the message “PA” appears on the display.
- II. Confirm with the “Chill” button.



- III. Use the “DOWN” button to select the password “-19”.

Confirm with the “Chill” button. The display will show the message “PA” again.

- IV. Repeat step I, holding down the “UP” and “DOWN” buttons to enter the list of parameters until the first parameter, called “CA1”, appears.



- V. Press the “CHILL” button to display the parameter value; use the “UP” and “DOWN” buttons to change the value. Use the “CHILL” button to confirm.
- VI. Once you have made the necessary changes to the parameters, repeat step I to exit the parameters section.

LIST OF PARAMETERS

Please note: For optimal machine operation, we recommend not changing the parameters and, if necessary, contacting the company to obtain the values from the design and functional specifications.

				<i>DESCRIPTION</i>
Parameter	Minimum	Maximum	Unit	Analogue inputs
CA1	-25.0	25.0	°C / °F (1)	cell probe offset
CA2	-25.0	25.0	°C / °F (1)	needle probe offset
CA3	-25.0	25.0	°C / °F (1)	evaporator probe offset
CA4	-25.0	25.0	°C / °F (1)	condenser probe offset
P0	0	1	----	probe type 0 = PTC 1 = NTC
P1	0	1	----	decimal point degree °C 1 = yes
P2	0	1	----	unit of temperature measurement (2) 0 = °C 1 = °F
P3	0	1	----	needle probe enable 1 = yes
P4	0	1	----	evaporator probe enable 1 = yes
P5	0	1	----	function of the fourth input 0 = high pressure input (digital input) 1 = condenser probe (analogue input)
P8	0	250	ds	delay in displaying variation in temperatures detected by the sensors
r0	0.1	15.0	°C / °F (1)	parameter differential r7, r8, r9, r10, r11 and r12
r1	1	500	min	duration of time-controlled blast chilling
r2	1	500	min	duration of time-controlled blast freezing
r3	-50.0	99.0	°C / °F (1)	temperature at end of blast chilling; also end temperature of the soft phase of temperature-controlled soft blast freezing (temperature detected by needle probe); see also parameter r5
r4	-50.0	99.0	°C / °F (1)	temperature at end of temperature-controlled deep freezing (temperature detected by needle probe); see also parameter r6
r5	1	500	min	maximum duration of temperature-controlled blast chilling; see also parameter r3
r6	1	500	min	maximum duration of temperature-controlled blast freezing; see also parameter r3
r7	-50.0	99.0	°C / °F (1)	working setpoint during blast chilling; also working setpoint during the soft phase of soft blast freezing (cell temperature); see also parameter r0

BLAST CHILLER SERVICE MANUAL: PARAMETERS – BOARD ALARMS

r8	-50.0	99.0	°C / °F (1)	working setpoint during deep freezing (cell temperature); see also parameter r0
r9	-50.0	99.0	°C / °F (1)	working setpoint during the hard phase of hard blast chilling (cell temperature); see also parameter r0
r10	-50.0	99.0	°C / °F (1)	working setpoint during post blast chilling conservation (cell temperature); see also parameter r0
r11	-50.0	99.0	°C / °F (1)	working setpoint during post blast freezing conservation (cell temperature); see also parameter r0
r12	-50.0	99.0	°C / °F (1)	working setpoint during pre-cooling (cell temperature); see also parameter r0
r13	-50.0	99.0	°C / °F (1)	end temperature of the hard phase of temperature-controlled hard blast chilling (temperature detected by needle probe)
r14	10	100	%	hard phase of temperature-controlled hard blast chilling (understood as a percentage of the value established with parameter r1); also the duration of the soft phase of time-controlled soft blast freezing (understood as a percentage of the value established with parameter r2)
r15	-50.0	99.0	°C / °F (1)	temperature below which the count of the maximum duration of temperature-controlled blast chilling and the maximum duration of temperature-controlled blast freezing begins (temperature detected by the needle probe)
r16	0	2	----	type of operating cycle that can be selected 0 = blast chilling and conservation 1 = blast chilling and conservation or blast freezing and conservation 2 = blast freezing and conservation
r17	0.0	99.0	°C / °F (1)	minimum difference between “temperature detected by the needle probe and the temperature of the cell” such that the first phase of the test to verify the correct insertion of the needle probe is considered successfully completed (consider the difference without a sign) 0.0 = the test will not be performed (neither the first nor the second phase)
r18	1	99.0	s	duration of the second phase of the test to verify correct insertion of the needle probe
r19	0	1	----	value that can be modified quickly while in the “on” state before starting the operating cycle 0 = work setpoint during blast chilling or blast freezing 1 = end of blast chilling or blast freezing temperature
r20	0	1	----	storing of value that can be modified quickly while in the “on” state before starting the operating cycle 0 = no (when the next cycle of the same type starts, the values established with parameters r1, r7 and r3 or those established with parameters r2, r4 and r8 will be used again) 1 = yes (when the next cycle of the same type starts, the values modified just before starting the previous

BLAST CHILLER SERVICE MANUAL: PARAMETERS – BOARD ALARMS

				cycle of the same type will be used again)
r21	0	1	----	mode with which an operating cycle is started at a certain temperature rather than by a timer 0 = automatic (i.e. through the test to verify correct insertion of the needle probe) 1 = manual (i.e. by pressing and releasing the BLAST CHILLING or BLAST FREEZING button)
r22	0	1	----	pre-cooling activation mode 0 = manual (i.e. by pressing the BLAST CHILLING button for 1 second) 1 = both automatic (i.e. by switching from “stand-by” to “on”, then switching on the device) and manual (i.e. by pressing the BLAST CHILLING button for 1 second)
r23	0	50	s	duration of the buzzer activation to signal that the test to verify correct insertion of the needle probe has not been successfully completed
C0	0	240	min	minimum time between power reset after an interruption that occurs during an operating cycle and the switching on of the compressor
C1	0	240	min	minimum time between two consecutive compressor starts (3)
C2	0	240	min	minimum time between switching the compressor off and then on again (3)
C3	0	240	s	minimum duration of compressor activation
C4	0	240	min	duration of compressor shut-down during the cell probe error (code “Pr1”) which occurs during conservation; see also parameter C5
C5	0	240	min	duration of compressor start-up during the cell probe error (code “Pr1”) which occurs during post blast chilling conservation; see also parameter C4
C6	0	199.0	°C / °F (1)	condenser temperature above which an overheated condenser alarm is activated (code “COH”) (4)
C7	0	199.0	°C / °F (1)	condenser temperature above which a blocked compressor alarm is activated (code “CSd”) (5)
C8	0	15	min	blocked compressor alarm delay (code “CSd”) (5)
C9	0	240	min	duration of compressor start-up during the cell probe error (code “Pr1”) which occurs during post blast freezing conservation; see also parameter C4
d0	0	99	h	defrost interval (7) 0 = interval defrost will never be activated
d1	0	3	----	type of defrost 0 = electric (during defrost the compressor will be switched off, the defrost output will be activated and the evaporator fan will be switched off) 1 = hot gas (during defrost the compressor will be switched on, the defrost output will be activated and the evaporator fan will be switched off) 2 = air (during defrost the compressor will be switched off and the defrost output will be activated;

BLAST CHILLER SERVICE MANUAL: PARAMETERS – BOARD ALARMS

				the evaporator fan will be switched on, regardless of the door status, i.e. regardless of the status of the micro door input) 3 = air with door open (during defrost the compressor will be switched off and the defrost output will be activated; the evaporator fan will be switched on, provided that the door is open, i.e. provided that the micro door input is active and that the i0 parameter is set to a value other than 0)
d2	-50.0	99.0	°C / °F (1)	defrost end temperature (evaporator temperature); see also parameter d3
d3	0	99	min	if parameter P4 is set at 0, duration of defrost if parameter P4 is set at 1, maximum duration of defrost; see also parameter d2 0 = defrost will never be activated
d4	0	1	-----	defrost at the start of blast chilling and at the start of blast freezing 1 = yes
d5	0	99	min	defrost delay from start of conservation 0 = defrost will be activated after the time established with parameter d0
d7	0	15	min	drip time (during the drip phase the compressor and the evaporator fan will remain off and the defrost output will be deactivated)
d15	0	99	min	minimum duration of compressor activation when defrost is activated so that it can be activated (only if parameter d1 is set to 1) (8)
d16	0	99	min	pre-drip time (only if parameter d1 is set to 1; during the drip time the compressor and the evaporator fan will be switched off and the defrost output will remain activated)
A1	0.0	99.0	°C / °F (1)	cell temperature below which the minimum temperature alarm is activated (relative to the working setpoint, i.e. "r10 - A1" during conservation after blast chilling and "r11 - A1" during conservation after freezing; code "AL"); see also parameter A11 (4)
A2	0.0	1	-----	enabling of the minimum temperature alarm (code "AL") 1 = yes
A4	0.0	99.0	°C / °F (1)	cell temperature above which the maximum temperature alarm is activated (relative to the working setpoint, i.e. "r10 + A4" during conservation after blast chilling and "r11 + A4" during conservation after freezing; code "AH"); see also parameter A11 (4)
A5	0	1	-----	enabling of the maximum temperature alarm (code "AH") 1 = yes
A7	0	240	min	temperature alarm delay (code "AL" and code "AH")
A8	0	240	min	maximum temperature alarm delay (code "AH") from the end of evaporator fan standstill and the start of

BLAST CHILLER SERVICE MANUAL: PARAMETERS – BOARD ALARMS

				conservation
A10	0	240	min	duration of a power failure such as to cause memorisation of the power failure alarm (code "PF") when power is restored 0 = the alarm will not be signalled
AA	0.0	240	s	duration of buzzer activation at the end of blast chilling and blast freezing
A11	0.1	15.0	°C / °F (1)	differential of parameters A1 and A4
A13	0	1	----	storing of alarm for temperature-controlled blast chilling or temperature-controlled blast freezing not completed within the maximum duration ("tiME" code) 1 = yes
F0	0	2	----	evaporator fan activity during pre-cooling, blast chilling and blast freezing 0 = off 1 = on; see also parameters F16 and F17 2 = parallel to compressor; see also parameters F9 and F17
F1	-50.0	99.0	°C / °F (1)	evaporator temperature above which the evaporator fan is switched off during conservation (only if parameter F2 is set to 3); see also parameter F8 (11)
F2	0	3	----	evaporator fan activity during conservation 0 = off 1 = on 2 = parallel to compressor; see also parameter F9 3 = on; see also parameters F1
F3	0	15	min	evaporator fan standby time (during evaporator fan standby the compressor may be on, the defrost output will remain deactivated and the evaporator fan will remain off)
F8	0.1	15.0	°C / °F (1)	differential of parameters F1, F16 and F17
F9	0	240	s	delay in evaporator fan shut-down after the compressor has been switched off (only if parameter F0 and/or parameter F2 are set to 2)
F11	0.0	99.0	°C / °F (1)	condenser temperature above which the condenser fan is switched on (understood as F11 + differential and provided that the compressor is switched on); see also parameter F12 (4) (12) (13)
F12	0	240	s	delay in switching off the condenser fan after compressor shut-down
F15	0	240	s	evaporator fan delay from door closing or from deactivation of the micro door input
F16	-50.0	99.0	°C / °F (1)	evaporator temperature above which the evaporator fan is switched off during cooling, blast chilling and blast freezing (only if parameter F0 is set to 1); see also parameter F8 (11)
F17	-50.0	99.0	°C / °F (1)	cell temperature above which the evaporator fan is switched off during pre-cooling, blast chilling and blast freezing (only if parameter F0 is set to 1 or 2);

BLAST CHILLER SERVICE MANUAL: PARAMETERS – BOARD ALARMS

				see also parameter F8
i0	0	2	----	effect caused by the door opening, or rather by the activation of the micro door input (14) 0 = no effect 1 = the compressor and the evaporator fan will be switched off and the cell light will be switched on; after the time established with parameter i2 the display will show the code "id" flashing and the buzzer will be activated (until the door is closed); see also parameter F15 (15) 2 = the evaporator fan will be switched off and the cell light will be switched on; after the time established with parameter i2 the display will show the code "id" flashing and the buzzer will be activated (until the door is closed); see also parameter F15
i1	0	1	----	type of micro door input contact 0 = normally open (input active with closed contact) 1 = normally closed (input active with open contact)
i2	-1	120	min	delay in signalling the door open alarm (code "id"); once the time established with the parameter has elapsed, the compressor is switched off -1 = the alarm will not be signalled
i5	0	1	----	effect caused by the activation of the high pressure input 0 = no effect 1 = the compressor and the evaporator fan will be switched off and the condenser fan will be switched on; once the time set with parameter i7 has elapsed, the cycle is terminated. If the input is released, the HP signal remains on the display until any key is pressed (the machine does not have to be set in standby). No cycle can be started until the alarm is reset.
i6	0	1	----	type of high pressure input contact 0 = normally open (input active with closed contact) 1 = normally closed (input active with open contact)
i7	-1	240	s	delay in signalling the high pressure alarm (code "HP") -1 = the alarm will not be signalled
u0	0	1	----	utility managed by output K2 (16) 0 = defrost (in this case parameters "d" will be significant) 1 = evaporator fan (in this case parameters "F" will be significant)
u1	0	1	----	utility managed by output K3 (16) 0 = door heating element (in this case parameters u5 will be significant) 1 = condenser fan (in this case parameters P5, F11 and F12 will be significant)

BLAST CHILLER SERVICE MANUAL: PARAMETERS – BOARD ALARMS

u2	0	1	----	enabling manual on/off of the cell light during “stand-by” status (17) 1 = yes
u5	-50.0	99.0	°C / °F (1)	cell temperature above which the door heating elements are switched off (4)
u6	1	240	min	if parameter u11 is set at 1, maximum duration of needle probe heating; see also parameter u7 if parameter u11 is set at 2, duration of UV light activation for the sterilisation cycle
u7	-50.0	99.0	°C / °F (1)	temperature at end of needle probe heating (temperature detected by the needle probe); see also parameter u6
u11	0	2	----	utility managed by output K5 (16) 0 = cell light (in this case the AUXILIARY button and parameters i0 and u2 will be significant) 1 = needle probe heating (in this case the AUXILIARY button and parameters u6 and u7 will be significant) 2 = UV light (in this case the AUXILIARY button and parameter u6 will be significant)
LA	1	247	----	device address
Lb	0	3	----	baud rate 0 = 2,400 baud 1 = 4,800 baud 2 = 9,600 baud 3 = 19,200 baud
LP	0	2	----	parity 0 = none (no parity) 1 = odd 2 = even

ACCESS TO SMART FUNCTIONS



Press the DOWN button for more than three seconds to access the Smart Function sub-menu
 Press the DOWN button to display RCH, PR1, PR2, PR3
 Then press the Chill button to display the value read

4.2 ALARMS

In the event of an anomaly, the display shows a flashing alarm message with a unique code. Consult the next chapter on Troubleshooting for diagnostics and resolution of problems related to alarms.

The following alarms can be displayed by Joy gamma blast chillers:

- **Pr1:** Chamber Probe



- **Pr2:** Needle Probe



- **Pr3:** Evaporator Probe



- **AH:** High Temperature Alarm



- **AL:** Low Temperature Alarm



- **HP:** High Pressure Alarm



Follow the instructions provided by the equipment and contact Customer Service if required, remembering to:

- Disconnect the equipment from the electrical system;
- Deactivate the protection switch upstream of the equipment;

5. TROUBLESHOOTING

5.1 ALARMS

ALARM	ALARM DESCRIPTION	POSSIBLE CAUSES	NECESSARY ACTIONS
Pr1	Cell probe alarm	Probe connector disconnected from terminal. Probe and/or probe cable damaged or interrupted.	The blast-chiller will run until the end of the active cycle. No further cycle can be run until the probe is replaced by Technical Service. CALL SERVICE.
Pr2	Needle probe sensor alarm	Improper use of the needle probe (e.g. pinched or frayed wire). Connector fault. Probe fault. Circuit Board Fault	Cycle running: <ul style="list-style-type: none"> The cycle switches to time mode During STANDBY phase: <ul style="list-style-type: none"> The cycle can be started in time mode. Replace probe. Replace board. Call Service to restore full functionality.
Pr3	Evaporator probe alarm	Probe connector disconnected from terminal. Probe and/or probe cable damaged or interrupted.	The blast-chiller works: the defrost setting is time-dependent. CALL SERVICE.

BLAST CHILLER SERVICE MANUAL: PARAMETERS – BOARD ALARMS

HP	Safety pressure switch tripped	<p>The working ambient temperature is too high.</p> <p>The condenser fan does not work.</p> <p>The food load exceeds the suggested values.</p> <p>Condensing coil clogged with dust.</p>	<p>Reposition the machine to ensure proper ventilation.</p> <p>The blast-chiller is locked and only the condenser fan remains in operation.</p> <p>Check the connections of the fan and/or run condenser if present.</p> <p>Check for any obstructions in the condensing coil.</p> <p>Clean the condensing coil.</p> <p>CALL CUSTOMER SERVICE.</p>
door	Door open Stop cycle.	<p>The door stays open beyond the permitted limit. Faulty or interrupted closing device (magnetic micro).</p>	<p>Make sure that the machine door is closed and that any physical obstructions are not preventing the door from closing.</p> <p>Check micro connections.</p> <p>If the alarm remains active call Service.</p>
AH	High cabinet temperature	<p>Door open.</p> <p>Food in the cold cabinet is too hot.</p> <p>Check the cabinet probe.</p> <p>Refrigerant leak.</p> <p>Ice or frost on evaporator.</p> <p>Check parameter A4.</p>	<p>Cabinet temperature has exceeded the set limit in addition to the signal delay.</p> <p>Cycle in continuous operation.</p> <p>Perform defrost cycle.</p> <p>Check the condition of the gasket.</p> <p>Check the cabinet temperature with an external thermometer.</p> <p>If the alarm persists even when the cabinet temperature is low, call Service.</p>
AL	Low cabinet temperature (only for positive or negative holding cycles)	<p>Low set delay time.</p> <p>Set temperature difference too small.</p> <p>Evaporator frozen.</p> <p>Evaporator fan not working.</p> <p>Compressor always ON.</p>	<p>The cabinet temperature is below the cycle temperature setpoint minus the differential.</p> <p>The cycle will continue until it stops.</p> <p>Open the door to raise the temperature inside the cabinet and check after about 3 minutes.</p> <p>Start a manual defrost cycle.</p>

BLAST CHILLER SERVICE MANUAL: PARAMETERS – BOARD ALARMS

		<p>Non-compliant temperature probe Check parameter A1.</p>	<p>Check compressor relay or contactor. Check internal temperature with reference thermometer If the problem persists, call Service.</p>
tim	<p>Temperature-controlled blast chilling/freezing timeout alarm</p>	<p>Evaporator frozen. Evaporator fan not working. Non-compliant temperature probe Check parameter r5,r6.</p>	<p>Check the internal load. Start a manual defrost cycle. Check internal temperature with reference thermometer If the problem persists, call Service.</p>

5.2 OTHER FUNCTIONS

DEFECT	POSSIBLE CAUSES	NOTES FOR SERVICE
The display is switched off (OFF) while the main switch is on.	Display connector disconnected.	Switch the unit On/Off. If the problem persists, call Service.
The display is locked and does not react.	No power supply. Shorted fuses. Faulty electrical contacts. Problems with the board	Switch the unit On/Off. If the problem persists, call Service.
External noise/vibration with cycle ON.	Unit not level. Water collection tray located underneath the motor vibrating. Condenser panel not secured.	Level the machine by operating the adjustable feet. Remove the water in the tray and adjust the support guides. Secure the condenser panel. If the problem persists, call Service.
Internal noise/vibration with cycle ON.	Tray holders are not aligned. Internal fan obstruction. Evaporator fan not properly secured.	Check that the right/left holders are properly levelled. Check that the cabinet fan is working properly without obstructions. If the problem persists, call Service.
The machine takes too long to reach the desired temperature.	High food load. Refrigerant leakage. Condensing coil clogged with dust. Solenoid valve fault. Cabinet fan is not connected correctly. Thermostatic valve needs adjustment. Thermal insulation of piping Damaged Evaporator loaded with frost.	Reduce the food load in the cell. Clean the condensing coil. Defrost. If the problem persists, call Service.
Compressor malfunction	The compressor does not start.	CALL SERVICE.

BLAST CHILLER SERVICE MANUAL: PARAMETERS – BOARD ALARMS

	<p>Compressor oscillates intermittently or discontinuously.</p> <p>Compressor thermal relay tripped.</p> <p>Compressor noisy.</p> <p>Clicson tripped.</p> <p>Contactor failure.</p> <p>Thermal relay tripped.</p>	
Evaporator fan malfunction	<p>Safety micro fault.</p> <p>Failure on run condenser</p> <p>Fan condenser</p> <p>Faulty or short-circuited fan.</p>	<p>Check magnetic micro operation.</p> <p>Check the status of the fan condenser in the electrical panel.</p> <p>Check fan operation and replace if necessary.</p>
Condenser fan malfunction	<p>Compressor not working.</p> <p>Electrical fan condenser fault</p> <p>Pressure switch tripped</p> <p>Faulty or short-circuited fan.</p>	<p>Check compressor operation.</p> <p>Check the status of the fan condenser in the electrical panel.</p> <p>Check whether the pressure switch has tripped.</p> <p>Check fan operation and replace if necessary.</p> <p>Check that the fan power supply is present.</p>
Door does not close properly.	<p>Worn gasket.</p> <p>Door misalignment.</p>	<p>Replace gasket.</p> <p>Check the correct absorption/surface temperature of the door heating element.</p> <p>Adjust door brackets.</p>

Once the above checks have been carried out, if the defect persists, contact Customer Service, remembering to indicate:

- The nature of the defect
- The machine code (1)
- The serial number (5)



5.3 REFERENCE VALUES

Below are the reference values of the machine's basic operating parameters under standard conditions and with an empty refrigerated compartment.

These values can be taken as a reference for understanding and troubleshooting problems on the machine

SBU15GL...				
Ambient temperature 32°C	in chilling at -25 °C	in conservation at -22 °C	In blast chilling at -5 °C	In conservation at +2 °C
Suction temperature	12 °C	16 °C	23 °C	15 °C
Drain temperature	85 °C	75 °C	84 °C	63 °C
Time down from 30°C to -25°C	10 min			

SBU20GL...-SBU20GT...				
Ambient temperature 32°C	in chilling at -25 °C	in conservation at -22 °C	In blast chilling at -5 °C	In conservation at +2 °C
Suction temperature	26 °C	25 °C	37 °C	36 °C
Drain temperature	101 °C	96 °C	98 °C	80 °C
Time down from 30°C to -25°C	15.5 min			

SBU40GT				
Ambient temperature 32°C	in chilling at -25 °C	in conservation at -22 °C	In blast chilling at -5 °C	In conservation at +2 °C
Suction temperature	5 °C	9 °C	12 °C	20 °C
Drain temperature	69 °C	63 °C	65 °C	51 °C
Time down from 30°C to -25°C	12.5 min			

SBU65GT				
Ambient temperature 32°C	in chilling at -25 °C	in conservation at -22 °C	In blast chilling at -5 °C	In conservation at +2 °C
Suction temperature	-4 °C	-2 °C	9 °C	14 °C
Drain temperature	73 °C	65 °C	74 °C	50 °C
Time down from 30°C to -25°C	15 min			