

# IKA

designed for scientists

**MINISTAR digital**

ENGLISH

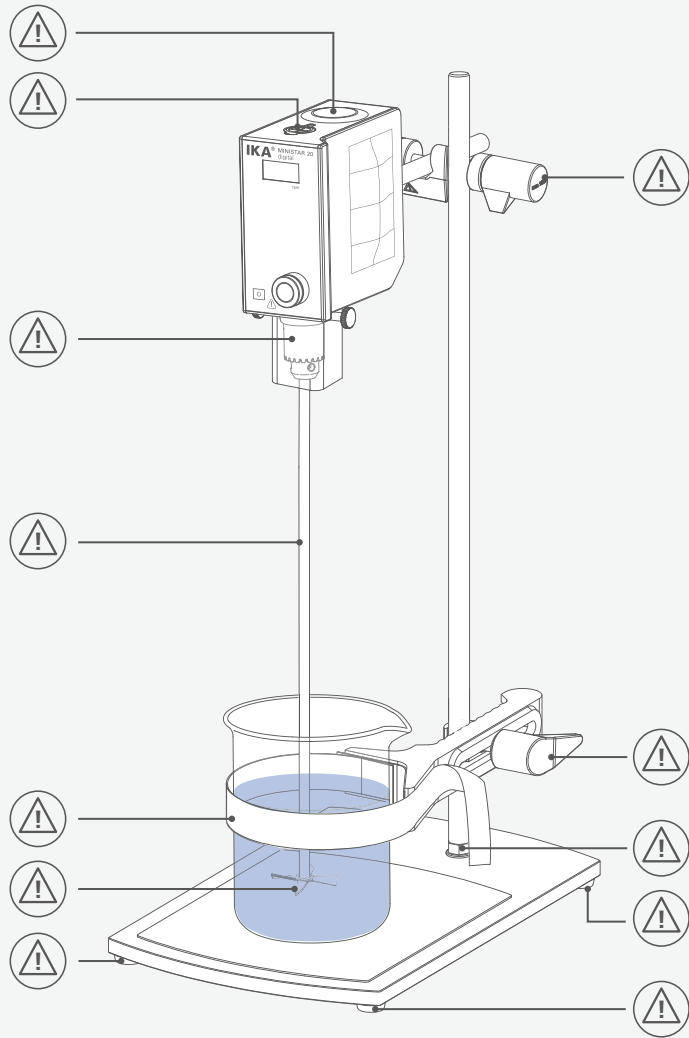









Fig. 1

	EU Declaration of conformity .....	6
	Explication of warning symbols .....	6
	Safety instructions.....	7
	Intended use.....	9
	Unpacking .....	10
	Useful information .....	10
	Speed .....	11
	Output shaft .....	11
	Operator panel and display .....	12
	Installation .....	12
	Operation .....	17
	USB interface .....	18
	Error codes .....	19
	Maintenance and cleaning .....	20
	Accessories .....	21
	Permitted stirrer tools.....	21
	Warranty .....	21
	Technical data.....	22



## EU Declaration of conformity





We declare under our sole responsibility that this product corresponds to the directives 2014/35/EU and 2006/42/EC, 2014/30/EU and 2011/65/EU and conforms with the following standards or normative documents: EN 61010-1, EN 61010-2-051, EN 61326-1, EN 60529 and EN ISO 12100.

A copy of the complete EU Declaration of conformity can be requested at sales@ika.com.







## Explication of warning symbols

### /// Warning symbols

-  **Danger:** Indicates an (extremely) hazardous situation, which, if not avoided, will result in death, serious injury.
-  **Warning:** Indicates a hazardous situation, which, if not avoided, can result in death, serious injury.
-  **Caution:** Indicates a potentially hazardous situation, which, if not avoided, can result in injury.
-  **Notice:** Indicates practices which, if not avoided, can result in equipment damage.

### /// General Symbols

- A** — Position number
-  Correct/Result  
Shows the correct execution or the result of an action step.
-  Wrong  
Shows the incorrect execution of an action step.
-  Note  
Displays action steps that require particular attention to detail.
-  Beep  
Shows action steps where audible beeps can be heard.

## Safety instructions



### /// General information

- › **Read the operating instructions completely before starting up and follow the safety instructions.**
- › Keep the operating instructions in a place where it can be accessed by everyone.
- › Ensure that only trained staff work with the device.
- › Follow the safety instructions, guidelines, occupational health and safety and accident prevention regulations.

-  **Danger!**
  - › Pay attention to the marked sites in Fig. 1.  
Beware of the risk of:
    - flammable materials
    - glass breakage as a result of mechanical stirring power

-  **Caution!**
  - › Wear your personal protective equipment in accordance with the hazard category of the medium to be processed, there is a risk of:
    - splashing of liquids
    - projectile parts
    - body parts, hair, clothing and jewellery getting caught.
  - › The device must only be used in a technically perfect condition.

### /// Device setup

-  **Danger!**
  - › Users must make sure that the standby key of the device can be accessed immediately, directly and without risk at any time. If installation or positioning cannot ensure this access at all times, an additional **EMERGENCY STOP** switch that can be easily accessed must be installed in the work area.

-  **Warning!**
  - › Ensure stable assembly. The vessel used for stirring must be secured.
  - › Use stirring shaft protective equipment!

-  **Notice!**
  - › Set up the stand in a spacious area on an even, stable, clean, non-slip, dry and fireproof surface.
  - › Remove the chuck key from the chuck before turning on the device.
  - › Place the power supply outside the working area of the device.
  - › Avoid knocking and impacting on the lower end of the shaft and the chuck gear teeth. Even minor, invisible damage can lead to imbalance and uneven shaft action.
  - › You must ensure that the stirring element is securely clamped in the chuck!
  - › All screw connections must be properly tightened.
  - › The high torque developed by the device requires particular care in the choice of stand, cross sleeve and anti-rotation element for the agitating vessel.

## /// Working with the device

### ⊗ **Danger!**

- › Do not use the device in explosive atmospheres, it is not EX-protected.
- › With substances capable of forming an explosive mixture, appropriate safety measures must be applied, e.g. working under a fume hood.
- › To avoid body injury and property damage, observe the relevant safety and accident prevention measures when processing hazardous materials.
- › The device is not suitable for hand-held operation.
- › Do not touch rotating parts during operation!

### ⚠ **Warning!**

- › Pathogenic materials must only be processed in closed vessels under a suitable fume hood. If you have any questions, please contact our application support.
- › The operation of a free rotating shaft end is prohibited. Therefore, for safety reason, only insert through the stirring tool over the upper edge of housing at standstill.

### ⊗ **Caution!**

- › Make certain that the unit is set at the lowest speed before commissioning; otherwise, the unit will begin running at the speed set in last operation. Gradually increase the speed. Please observe the max. permitted speed for the stirring element. Never set higher speed.

### ⚠ **Notice!**

- › Covers or parts that can be removed from the device without tools must later be refitted to ensure safe operation. This will prevent the infiltration of foreign objects, liquids and other contaminants.
- › Imbalance of the output shaft, the chuck and in particular the stirring tools can lead to uncontrolled resonant vibrational behavior of the device and the whole assembly. Glass apparatus and stirrer containers can be damaged or shattered by this. It can cause injury to the operator, also can damage the rotating stirring tool. In this case exchange the stirring tool for one without imbalance or remedy the cause of the imbalance. If there is still imbalance, return it to the dealer or the manufacturer along with a description of the fault.
- › There may be electrostatic activity between the medium and the output shaft which could cause a direct danger.
- › Never operate the device with the stirrer tools rotating freely. Ensure that parts of the body, hair, jewelry or items of clothing cannot be trapped by the rotating parts.
- › Pay attention when setting the speed to any imbalance of the stirrer tools and possible spraying of the medium to be stirred.
- › Ensure that the stand does not start to move.
- › Only process media that will not react dangerously to the extra energy produced through processing. This also applies to any extra energy produced in other ways, e.g. through light irradiation.
- › Reduce the speed if:
  - the medium splashes out of the vessel because the speed is too high,
  - the device is not running smoothly,
  - the device begins to move around because of dynamic forces,
  - an error occurs.

## /// Accessories

- › Protect the device and accessories from bumping and impacting.
- › Check the device and accessories beforehand for damage each time when you use them. Do not use damaged components.
- › Safe operation is only guaranteed with the accessories described in the "Accessories" section.
- › Must disconnect the power before changing stirring element and fitting allowed accessories.

## /// Power supply / switching off the device

### ⚠ **Notice!**

- › If the device is operated too long in overload or if the ambient temperature is too high, the device switches off permanently.
- › Disconnecting the device from the power outlet only works by removing the main cord from the socket.
- › The device must only be operated with the original power supply unit.
- › The outlet for the power supply must be easily accessible.
- › After an interruption in the power supply during a stirring process, the device does not restart automatically.
- › The device must only be opened by trained technicians, even during repair. The device must be unplugged from the power supply before opening. Live parts inside the device may still be live for some time after unplugging from the power supply.

## /// Disposal instructions

- › The device, accessories and packaging must be disposed of in accordance with local and national regulations.

## Intended use

### /// Use

- › For mixing / stirring liquids from low to medium viscosities with various stirring tools.
- › **Stand device** (chuck points down)

### /// Range of use

Indoor environments similar to that a laboratory of research, teaching, trade or industry area.

The safety of the user cannot be guaranteed:

- › if the device is operated with accessories that are not supplied or recommended by the manufacturer.
- › if the device is operated improperly or contrary to the manufacture's specifications.
- › if the device or the printed circuit board are modified by third parties.





## Unpacking

- › Please unpack the device carefully.
- › Any damage should be notified immediately to the shipping agent (post office, railway network or logistics company).

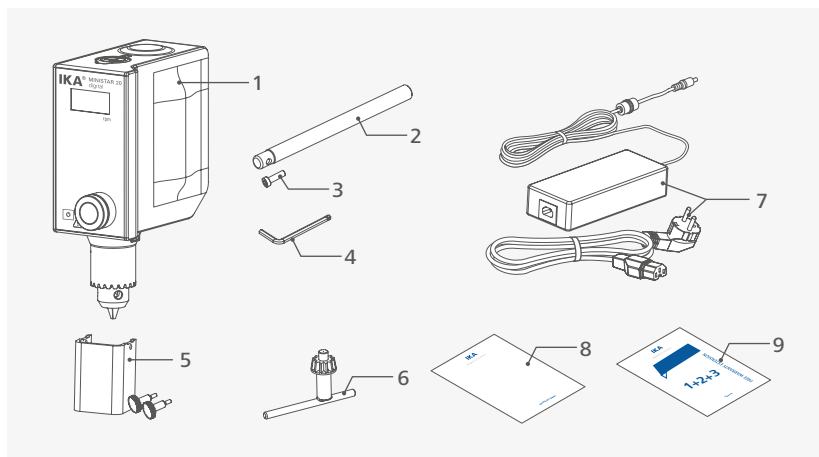

1	<b>MINISTAR digital</b>
2	Extension arm
3	Hexagonal socket screw
4	Hexagonal socket offset screw key
5	Shaft protector R 300 (with 2 fasten screws)

6	Chuck key
7	Power supply
8	User guide
9	Warranty card

## Useful information

The stirring device is suitable for continuous operation. The motor current is limited electronically. The device has an anti-stall and anti-overload system.

If a fault occurs, a safety circuit immediately switches off the motor permanently. The device starts with the last settings made.

## Speed

### /// Speed – normal operation

#### **Speed - regulated** (no variation in speed):

The speed is monitored and regulated by processor controlled. The target speed is constantly compared with the actual rotation speed value of the output shaft and variations corrected. This guarantees a constant speed even if the viscosity of the substance being stirred changes. Fluctuations in mains voltage within the permitted tolerance range have no effect on the quality of regulation and constancy of speed.

The speed is set using the front knob. During normal operations the speed value on the display corresponds to the speed of the output shaft in revolutions per minute (rpm).

### /// Speed – overload operation

When solid or semi-viscous substances are added, the stirrer can be run for a brief period at 130% its rated power. When running in the overload range (for instance if the viscosity has increased at a particular stage of the process) the speed will reduce to a degree sufficient to keep the torque on the stirrer shaft within the rated torque of the device.

#### Overload status 1:

The device is already running within the overload range, however, the actual speed does not match the set speed. This condition is maintained as long as neither the motor current nor the device temperature exceeds their permissible limit value. Display symbol: blinking of the target speed.

#### Overload status 2:

The device stop at a load above 130 % of the nominal torque. Message in the display (see "Error codes" section).

## Output shaft

The clamping chuck and output shaft permit clamping the recommend stirrer tools (see section "Permitted stirrer tools"). The output shaft is designed as a hollow shaft and the opening on the top side of the housing is closed with a plastic cover. When the stirrer cover is opened, it is possible for stirring shaft to be pushed out over the top edge of the housing at standstill, e.g. during changing container.

For safety reason, the stirrer cover must be pushed back into the opening of the housing so that it is properly closed. This is the only way to ensure that working with the unit is safe and that media cannot enter the device.

#### **Warning!**

Please see section "Safety instructions"!

## Operator panel and display

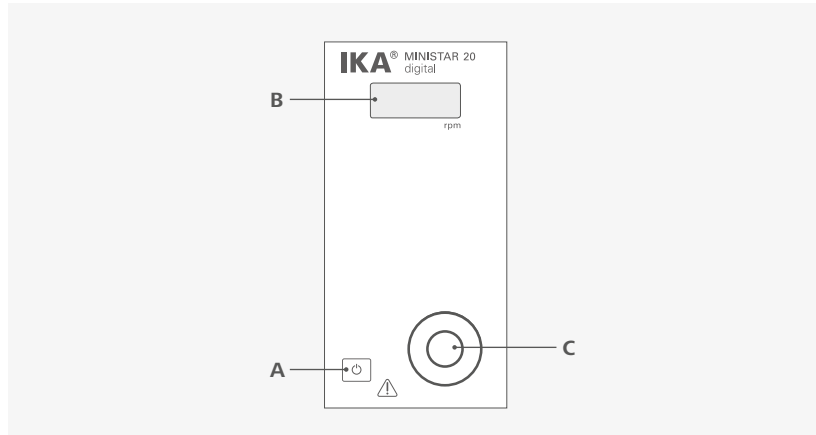

A	Standby key	Device switches on / enters standby (no disconnection from the power supply network)
B	Display	Display the speed value.
C	Control knob (Rotating / Pressing)	Set the speed by rotating. Start / stop the stirrer function by pressing.



## Installation

/// Assembling the extension arm to the overhead stirrer

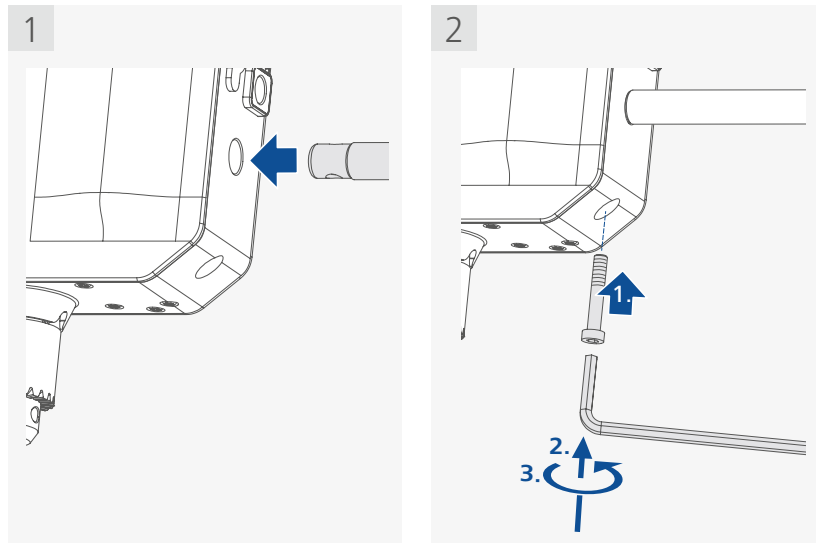

/// Assembling the overhead stirrer to the stand

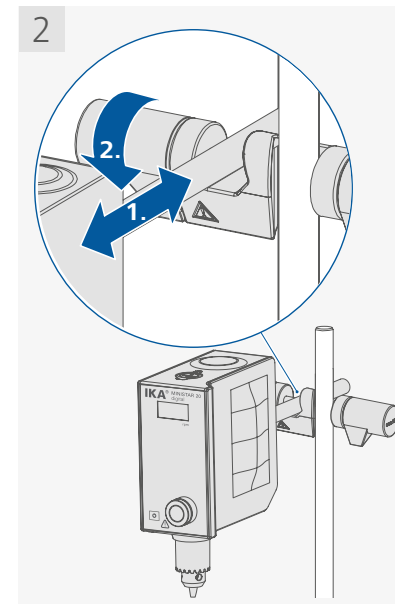
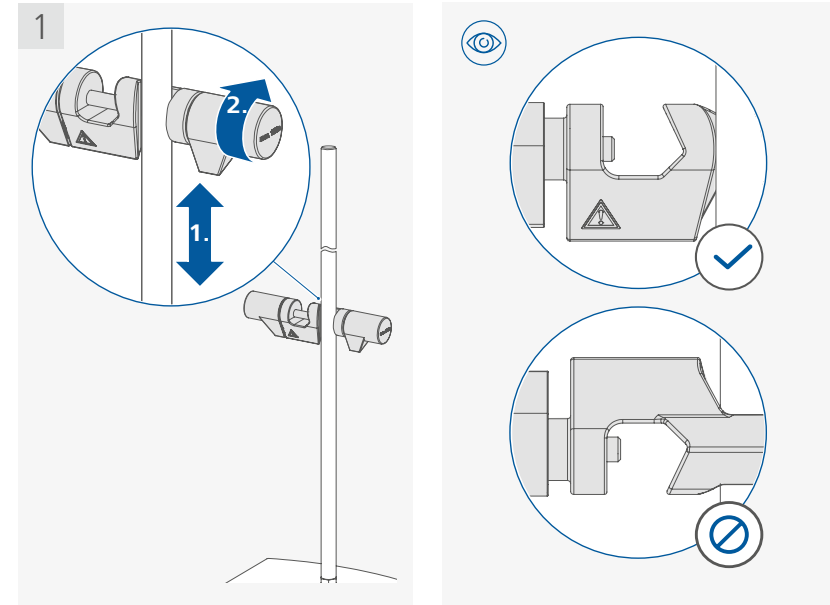

/// Assembling the stirring element using the chuck

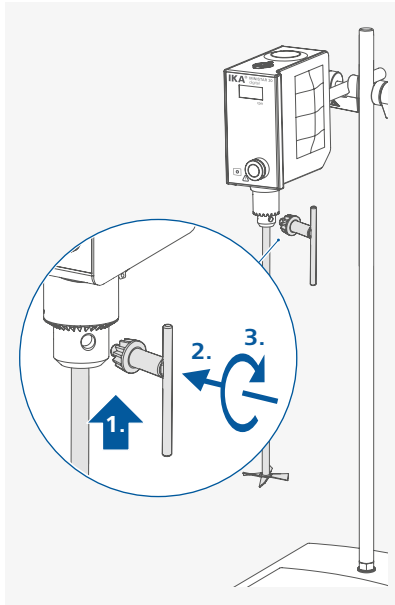

/// Assembling the stirring shaft protector

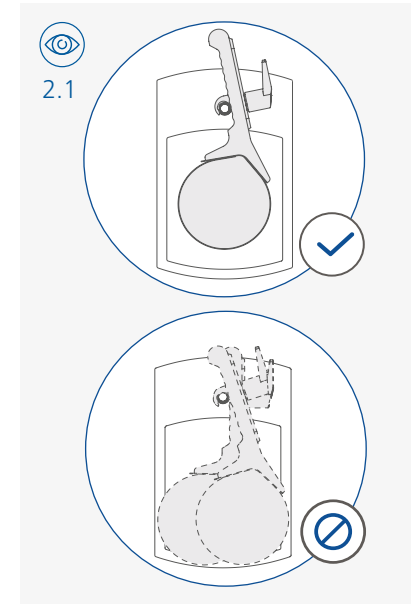
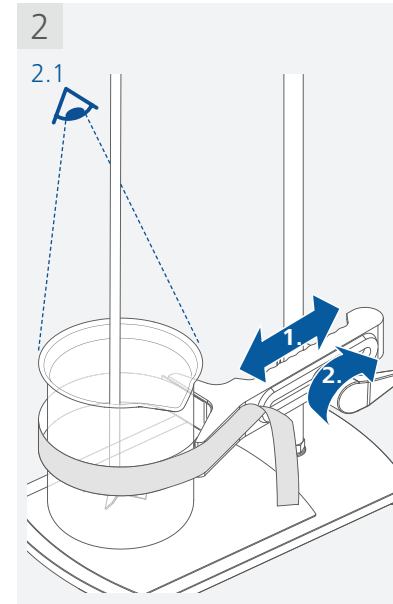
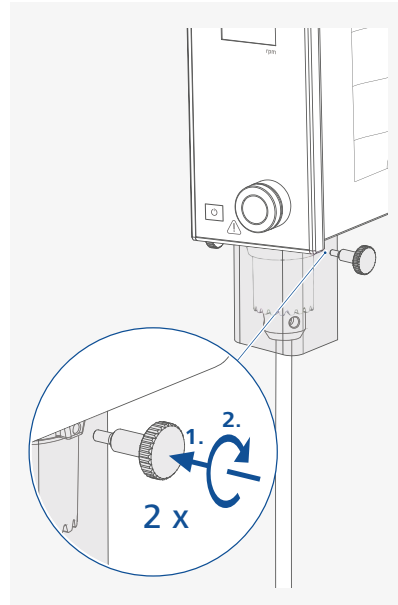

/// Securing the mixing vessel to the stand

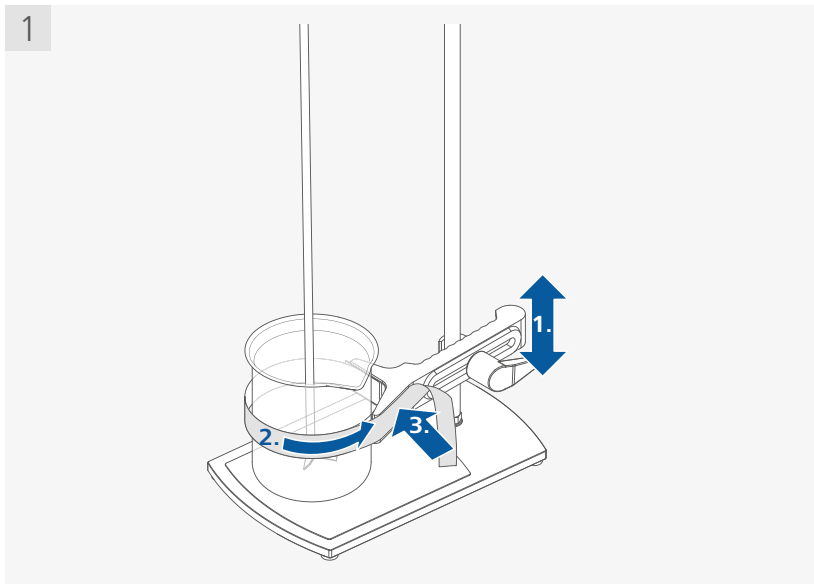

/// Attaching the power supply

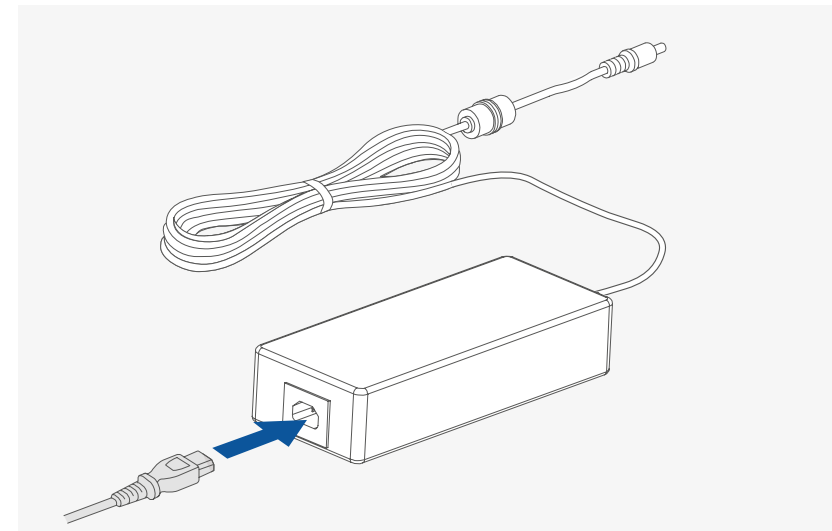

**⚠ Notice!**

The AC adapter is suitable for 100 VAC to 240 VAC.

### /// Connecting to the power

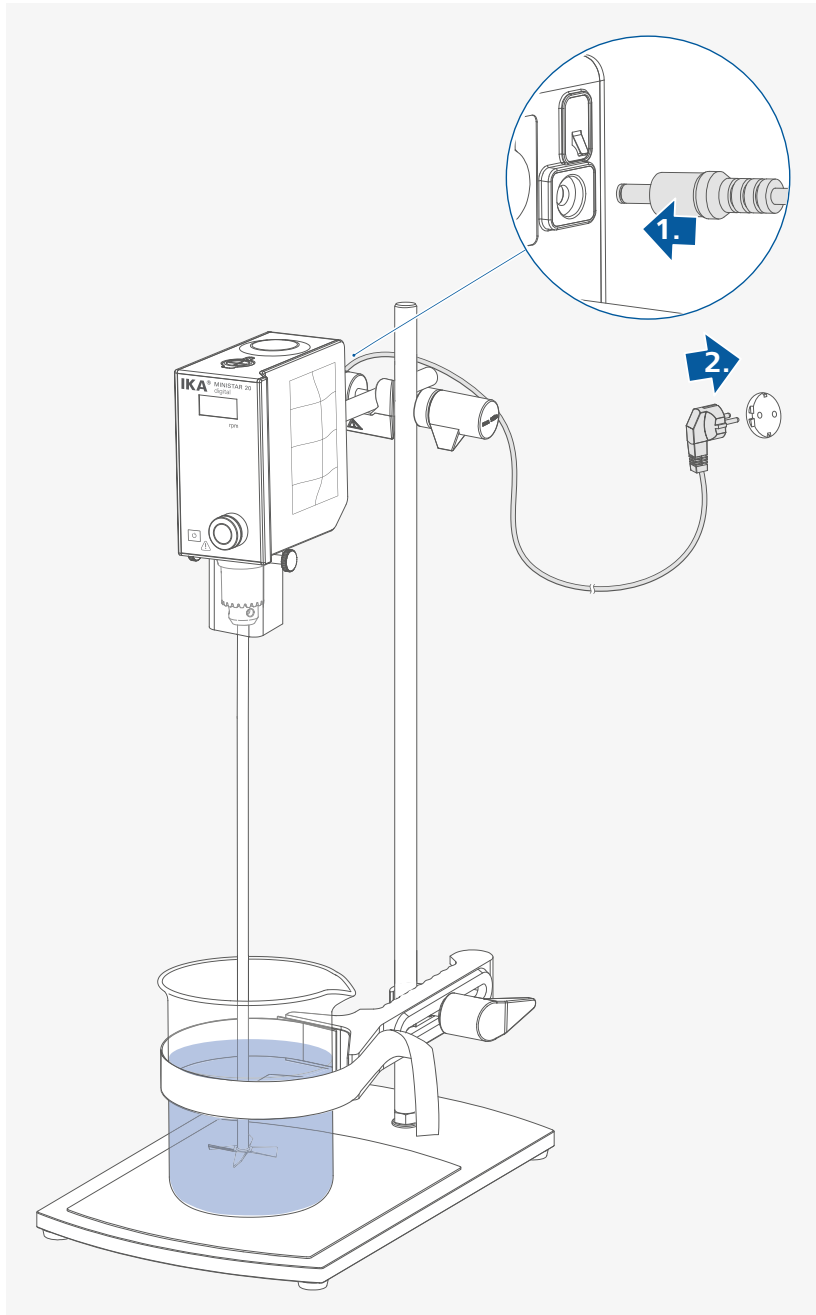

## Operation

### ⚠ Notice!

Secure the device to a stable stand with a cross sleeve.

The stirring vessel must always be securely fixed for safety reasons. You must also ensure that the mounting device (stand) is set up in such a way that it is not liable to topple and does not start to move during the stirring procedure.

If these conditions have been met, the machine is ready for operation when the mains plug is plugged in. If these conditions are not met, safe operation is not guaranteed and the machine could be damaged.

Observe the ambient conditions (temperature, humidity, etc.) listed under "Technical Data".

### /// Switching on

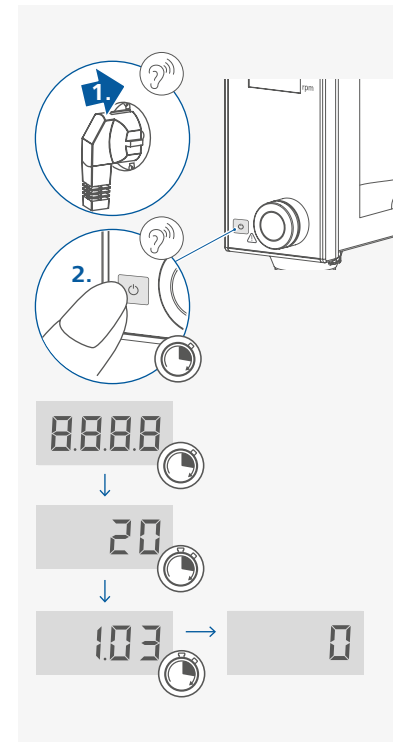

### /// Setting / Starting the speed

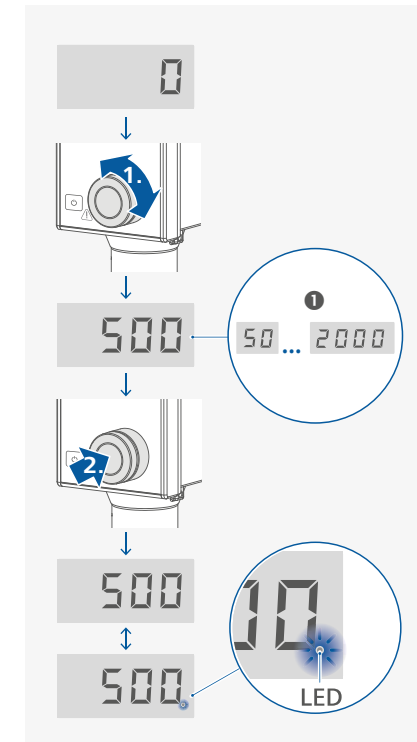

ⓘ Note: depending on device type.

### ⚠ Notice!

During stirring, the LED flashes in the display.



### /// Stopping / Switching off the device

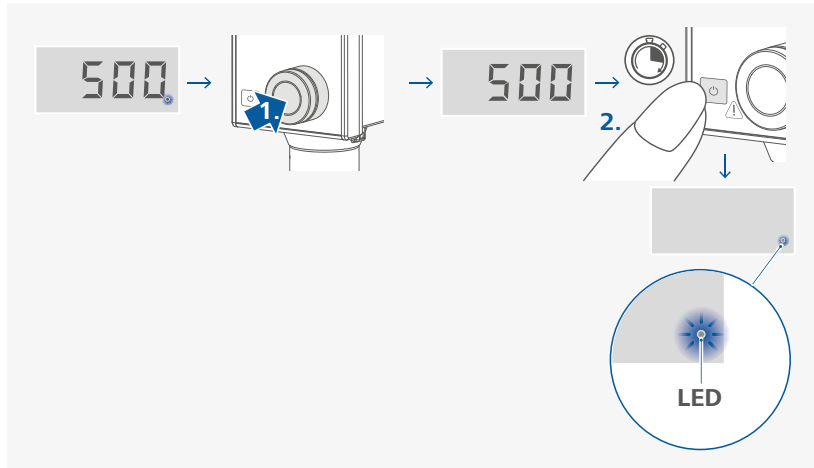

## USB Interface

The device can be connected to a PC via the USB interface and used for firmware update (USB cable is not included with the device).

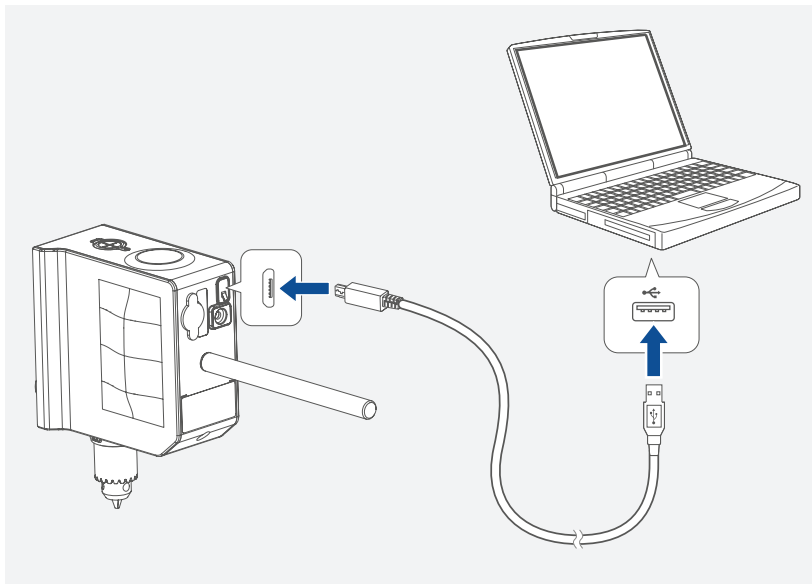

## Error codes

The fault is shown by an error code in the screen as following if the error occurs.

Proceed as follows in such cases:

- › Disconnect the device from the power supply.
- › Carry out corrective measures.
- › Restart device.

### E 3

Cause	› Temperature inside of the device is too high.
Effect	› Motor off
Solution	› Switch off the device and let it cool down. › Restart the device.

### E 4

Cause	› Motor blockage or overload.
Effect	› Motor off
Solution	› Disconnect the device from the power supply. › Decrease the load on the motor and restart device again.

### E 8

Cause	› Speed sensor fault or overload.
Effect	› Motor off
Solution	› Disconnect the device from the power supply. › Restart the device.

If the actions described fails to resolve the fault or another error code is displayed then take one of the following steps:

- › Contact the service department
- › Send the device for repair, including a short description of the fault.

## Maintenance and cleaning

The device is maintenance-free. It is only subject to the natural wear and tear of components and their statistical failure rate.

### /// Cleaning

For cleaning disconnect the mains plug!

Use only cleaning agents which have been approved by the manufacturer to clean the device: Water (containing surfactant) and isopropyl alcohol.

- › Wear protective gloves during cleaning the devices.
- › Electrical devices may not be placed in the cleansing agent for the purpose of cleaning.
- › Do not allow moisture to get into the device when cleaning.
- › Before using another than the recommended method for cleaning or decontamination, the user must ascertain with the manufacturer that this method does not destroy the device.

### /// Spare parts order

When ordering spare parts, please give:

- › Machine type
- › Serial number, see type plate
- › Item and designation of the spare part, see [www.ika.com](http://www.ika.com).
- › Software version.

### /// Repair

**Please send in device for repair only after it has been cleaned and is free from any materials which may constitute a health hazard.**

For repair, please request the "Decontamination Certificate" form the manufacturer or use the download printout of it from website: [www.ika.com](http://www.ika.com).

If you require servicing, return the device in its original packaging. Storage packaging is not sufficient. Please also use suitable transport packaging.

## Accessories

- › **R 1825** Plate stand
- › **R 1826** Plate stand
- › **R 1827** Plate stand
- › **R 182** Cross sleeve
- › **RH 3** Strap clamp
- › **FK 1** Flexible coupling

See more accessories on [www.ika.com](http://www.ika.com).

## Permitted stirrer tools

		max. speed (rpm)
<b>R 1342</b>	Propeller stirrer	≤ 2000
<b>R 1381</b>	Propeller stirrer	≤ 2000
<b>R 1382</b>	Propeller stirrer	≤ 2000
<b>R 1389</b>	Propeller stirrer , PTFE	≤ 800
<b>R 1311</b>	Turbine stirrer	≤ 2000
<b>R 1312</b>	Turbine stirrer	≤ 2000
<b>R 1300</b>	Dissolver stirrer	≤ 2000
<b>R 1303</b>	Dissolver stirrer	≤ 2000
<b>R 1352</b>	Centrifugal stirrer	≤ 2000
<b>R 1330</b>	Anchor stirrer	≤ 1000

See more permitted stirrer tools on [www.ika.com](http://www.ika.com).

## Warranty

In accordance with our warranty conditions, the warranty period is 24 months. For claims under the warranty please contact your local dealer. You may also send the machine direct to our factory, enclosing the delivery invoice and giving reasons for the claim. You will be liable for freight costs.

The warranty does not cover worn out parts, nor does it apply to faults resulting from improper use, insufficient care or maintenance not carried out in accordance with the instructions in this operating manual.



## Technical data

<b>Drive unit</b>		<b>MINISTAR 20 digital</b>	<b>MINISTAR 40 digital</b>	<b>MINISTAR 80 digital</b>
Speed range under nominal load	rpm	0 / 50 ... 2000	0 / 50 ... 1000	0 / 50 ... 500
Speed adjustment		Stepless		
Speed display		LED		
Speed setting accuracy	rpm	± 1		
Speed measurement deviation		Speed < 300 rpm: ± 3 rpm Speed > 300 rpm: ± 1 %		
Max. torque at stirrer shaft	Ncm	20	40	80
Max. stirring quantity (water)	l	15	25	50
Max. viscosity	mPa·s	10000	30000	60000
Permitted on time	%	100		
Nominal voltage	VDC	24		
Max. current	mA	2900		
Max. input power	W	69		
Max. output power at stirring shaft	W	42		
IP code according to EN 60529		IP 54		
Contamination level		2		
Protection at overload		motor current limitation		
Ambient temperature	°C	5 ... 40		
Ambient humidity (rel.)	%	80		
Drive		Brushless DC-Motor		
Clamping chuck-clamping range	mm	0.5 ... 8		
Hollow shaft internal diameter	mm	8.5		
Extension arm (Ø × L)	mm	13 × 160		
Dimensions (W × D × H) (without extension arm)	mm	70 × 147 × 193		
Weight (with extension arm and clamping chuck)	kg	1.56	1.72	1.72
Operation at a terrestrial altitude	m	max. 2000		
<b>Power supply</b>				
Input		100 ... 240 VAC 1.3 A 50 ... 60 Hz		
Output		24 VDC 90 W		
Protection class		I		

Subject to technical changes!



designed for scientists

---

#### **IKA-Werke GmbH & Co. KG**

Janke & Kunkel-Straße 10, 79219 Staufen, Germany  
Phone: +49 7633 831-0, Fax: +49 7633 831-98  
eMail: sales@ika.de

---

#### **USA**

IKA Works, Inc.  
Phone: +1 910 452-7059  
eMail: usa@ika.net

#### **KOREA**

IKA Korea Ltd.  
Phone: +82 2 2136 6800  
eMail: sales-lab@ika.kr

#### **BRAZIL**

IKA Brazil  
Phone: +55 19 3772 9600  
eMail: sales@ika.net.br

#### **MALAYSIA**

IKA Works (Asia) Sdn Bhd  
Phone: +60 3 6099-5666  
eMail: sales.lab@ika.my

#### **CHINA**

IKA Works Guangzhou  
Phone: +86 20 8222 6771  
eMail: info@ika.cn

#### **POLAND**

IKA Poland Sp. z o.o.  
Phone: +48 22 201 99 79  
eMail: sales.poland@ika.com

#### **JAPAN**

IKA Japan K.K.  
Phone: +81 6 6730 6781  
eMail: info\_japan@ika.ne.jp

#### **INDIA**

IKA India Private Limited  
Phone: +91 80 26253 900  
eMail: info@ika.in

#### **UNITED KINGDOM**

IKA England LTD.  
Phone: +44 1865 986 162  
eMail: sales.english@ika.com

#### **VIETNAM**

IKA Vietnam Company Limited  
Phone: +84 28 38202142  
eMail: sales.lab-vietnam@ika.com

---

Discover and order the fascinating products of IKA online:  
[www.ika.com](http://www.ika.com)

