



T-RACK BAKRE MAN TGE/VW CRAFTER 17- DUBBELHYTT

Art nr: TB90103 & ...24
Monteringsats: 93558



Installation

Produkten monteras genom håltagning i taket



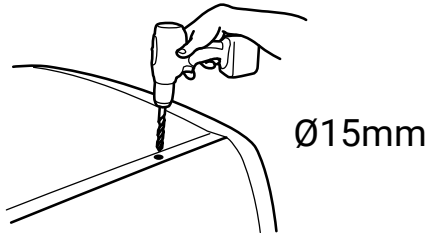
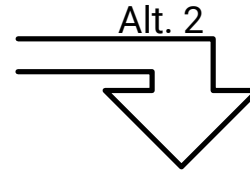
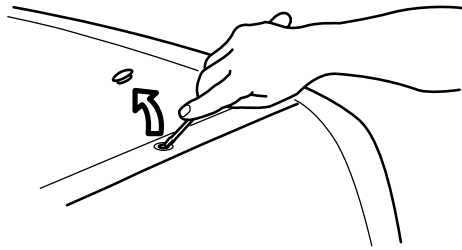
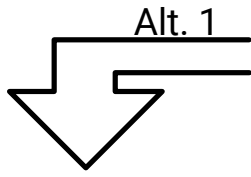

Ø15mm

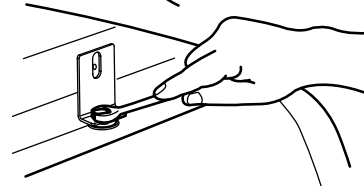
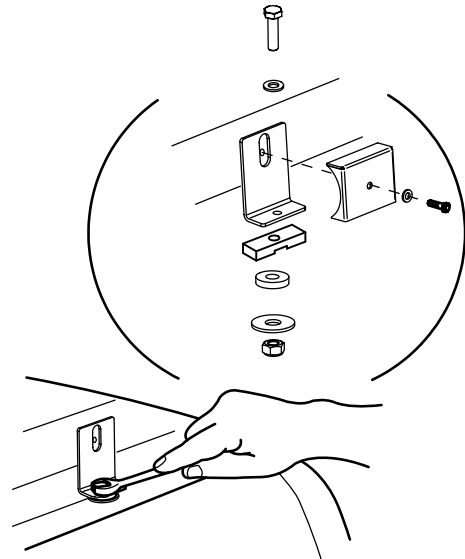
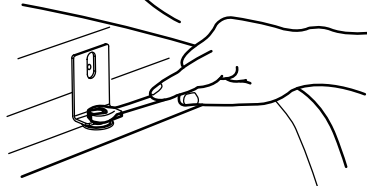
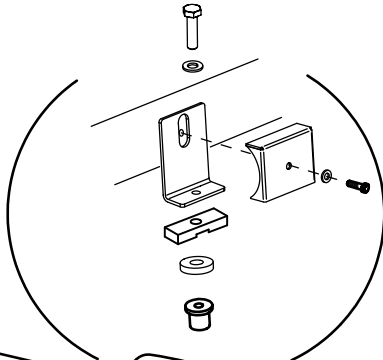

WellNut M8

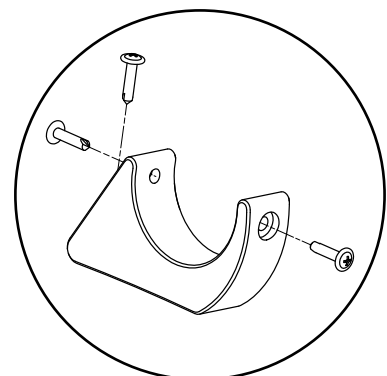
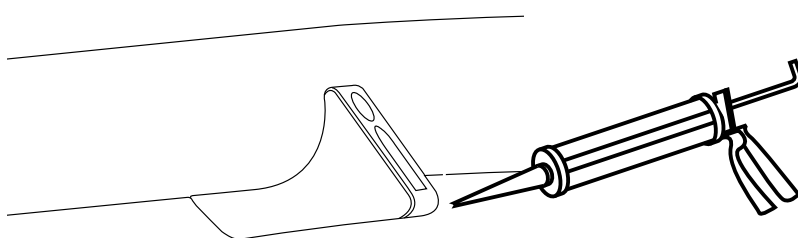
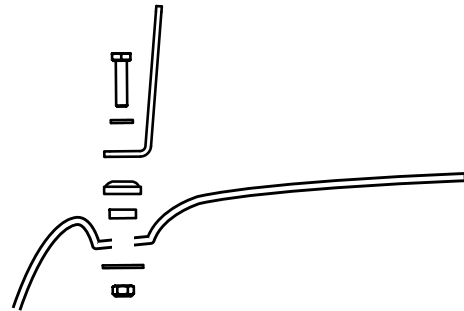
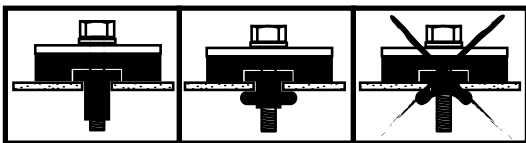

Nr	Ant	Ändring	Datum	Godk.
B		Takbåge uppdaterad	24-05-17	

* Alternativ för genomgående skruvförband.
Wellnut M8 Gummimutter (borras Ø15mm).

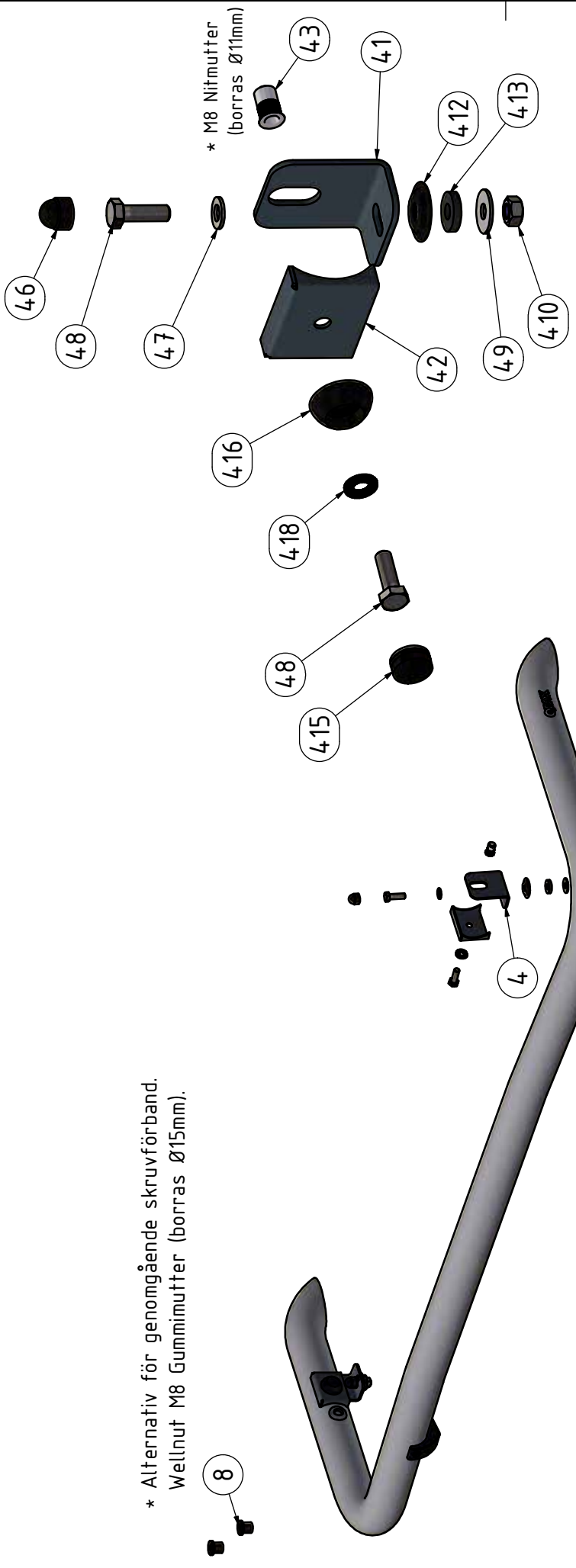

418	1	Bricka Nordlock M8 Bred	M8	34328
416	1	Hattbricka	Ø32mm	50921
415	1	Hatt		50920
413	1	Tätningsbricka	20x8x4	50935
412	1	Kupolbricka	M8	34350
410	1	Mutter M8 Locking	M8	34204
49	1	Bricka bred	8x22x1,5	34314
48	2	Skruv M6S	M8x25	34105
47	1	Bricka M8	M8	34302
46	1	Mutterskydd 13mm	M8	50944
43	1	Nitmutter M8 Alu	M8 Ø11mm 1.5-4.5	32211
42	1	Täcklock	T=2	100209
41	1	Vinkel 60mm (43) 90°	T=3	101205

8	2	Wellnut M8	M8 Ø15	34217
7	4	Skruv MRT-TT	M5x10	34235
6	2	Skruv RXS	4,2x19	34162
5	2	Magnetfäste	t=25	100141
4	2	Fäste för takbåge (låg)		98520
3	6	Kabelgenomföring membran	Ø20	96012
2	2	Dekal QPAX	54x17	60325
1	1	T-RACK takbåge	Ø60x3,5	B82-452
Pos	Ant		Dimension	Artikel nr/Referens
				SMST Titel

Konstr.	Riåad	Köp.	Kontr.	Stand.	Godk.	Dimension	Artikel nr/Referens
JNO	JNO					Skala 1:6	Ersätter
Dar ej annat anges, gäller SS-ISO 2768 - C och SMS 723 - B. Svetskvalité för sveisar enligt SS - ISO 5817 nivå C.							Ersatt av

QPAX
Tel: +46 (0)81 7 60 460 Mail: info@qpax.se

T-RACK bakre takbåge
VW Crafter H2 17-
Dubbelhytt

Filnamn 935558.idw Datum 2022-11-10
Art. nr 93558 Rev B