



T-RACK FIAT DUCATO, CITROËN JUMPER & PEUGEOT BOXER 15-

Art nr: TF90041 ..42 & ..43

TB90062 ..69 & ..70

Monteringssats: 93323-1



Installation

Produkten monteras i befintlig infästning



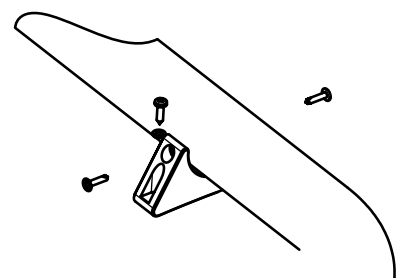
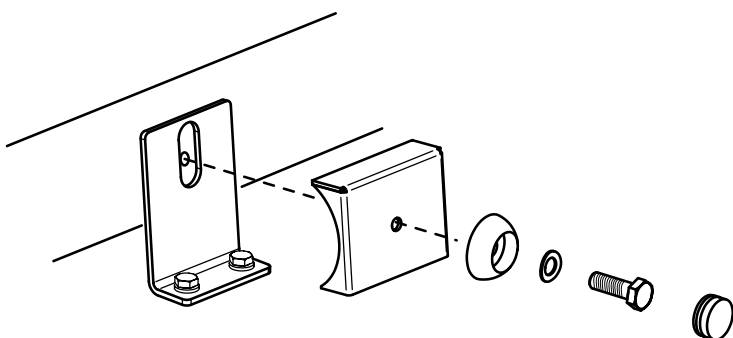
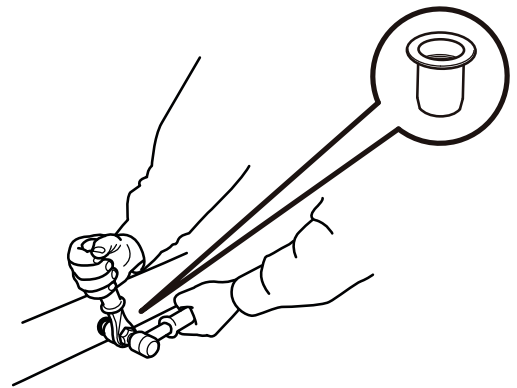
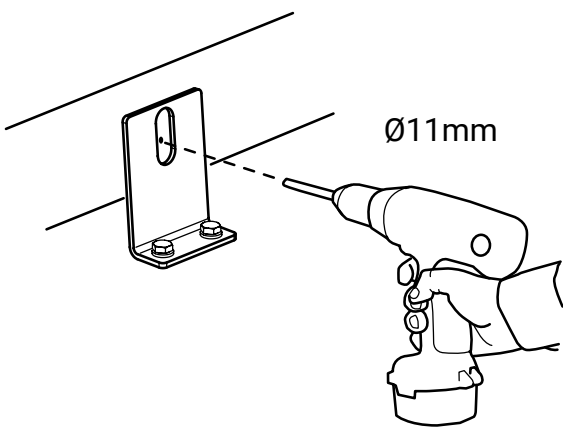
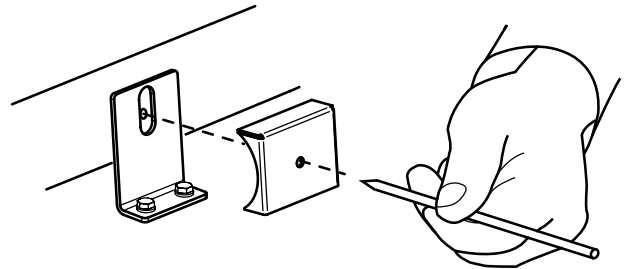
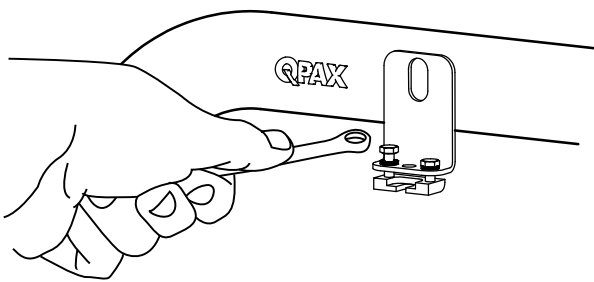
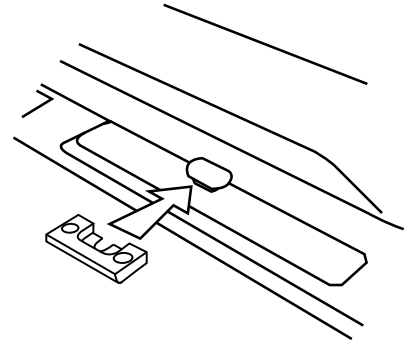
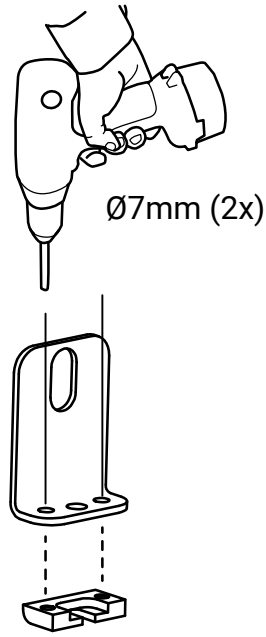
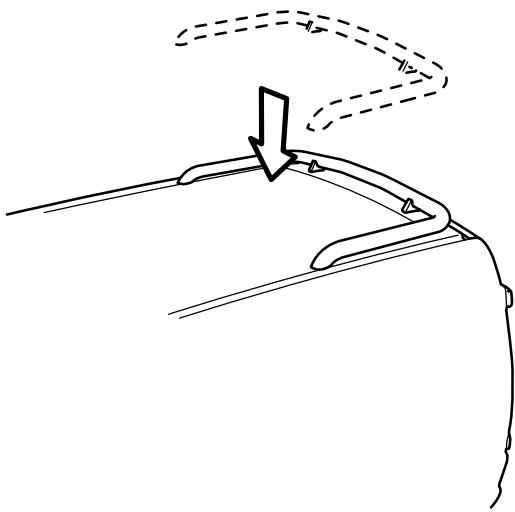

Nr	Ändring	Datum	Godk.
B	Bakre båge tillagd	2023-12-21	

Bakre

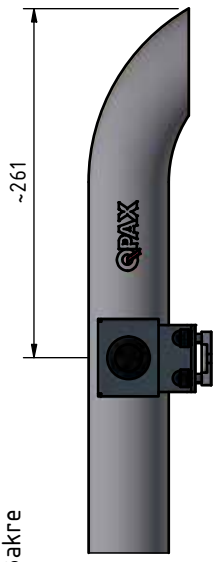

Främre

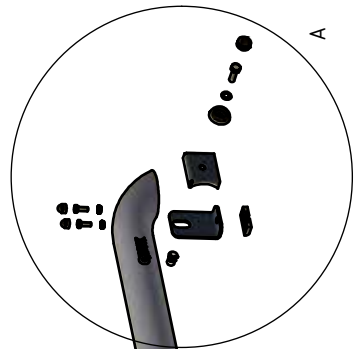

A (1 : 3)

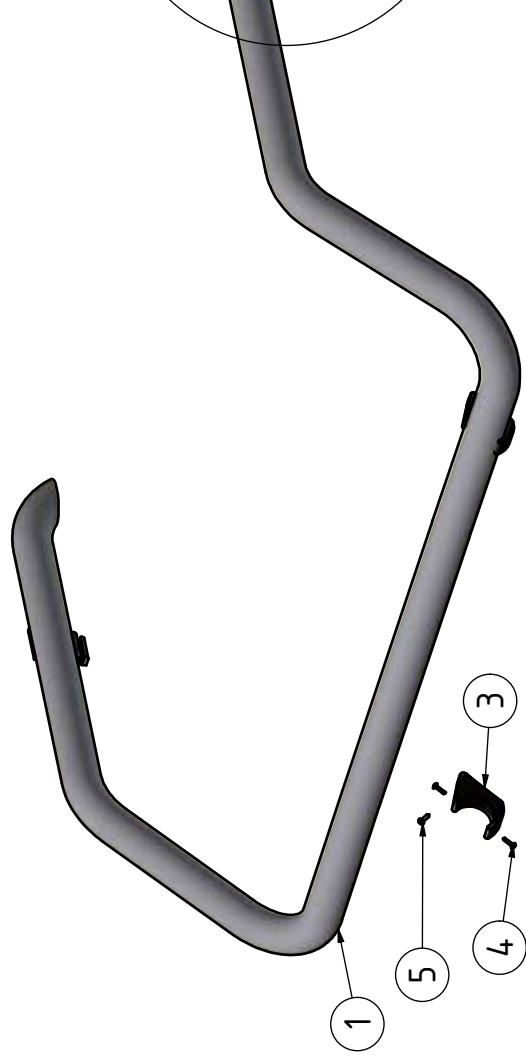
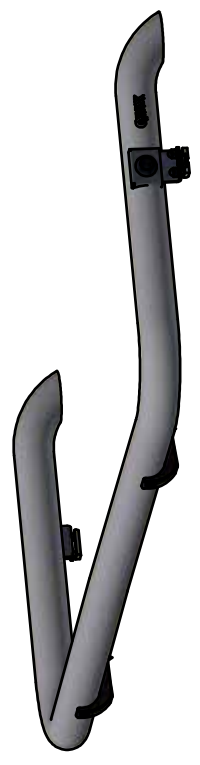

Pos	Ant	SMST Titel	Dimension	Artikel nr/Referens
16	2	Hatt		50920
15	2	Skruv M6S	M8x25	34105
14	2	Bricka fjäder M8 rostfri	15x8,6x0,8	34329
13	2	Hattbricka	Ø32mm	50921
12	2	Täcklock	T=2	100209
11	2	Låsbricka	Iveco/Fiat	10837
10	2	Vinkel 55mm 90°	T=3	100210
9	2	Nitmutter M8 Alu	M8 Ø11mm 1.5-4.5	32211
8	4	Bricka Nordlock M6	M6	34325
7	4	Skruv M6SH	M6x16	34192
6	4	Mutterskydd 10mm	M6	50942
5	2	Skruv RXS	4,2x19	34162
4	4	Montageskruv L19	4,2x19	34094
3	2	Magnetfäste	t=25	100141
2	2	Dekal QPAX	54x17	60325
1	1	T-RACK takbåge		FC-552
				Artikkel nr/Referens

M8 Nitmutter
Ø11mm

6: Borrar Ø7mm,
motsvarande hålbild Pos 12. 11

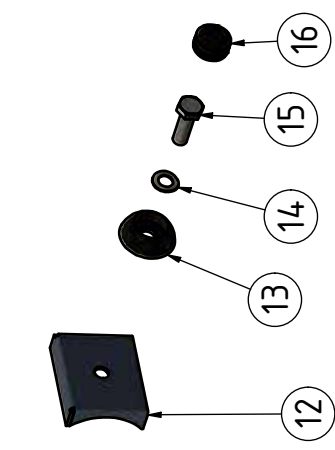

Bakre: BC-552



T-RACK takbåge
Främre & bakre H3
Ducato, Jumper, Boxer

Filnamn	93323-1.idw	Datum	2023-02-07
Art. nr	93323-1	Rev	B

Konstr.	JNO	Ritad	JNO	Kop.		Kontr.		Stand.		Godk.		Skala	1 : 8	Ersätter		Ersatt av
---------	-----	-------	-----	------	--	--------	--	--------	--	-------	--	-------	-------	----------	--	-----------

Där ej annat anges, gäller SS-ISO 2768 - C och SMS 723 - B. Sveriskvalite för sveitar enligt SS - ISO 9817 m.v.t.C.