



DETAILS



1. Independent light switches for inner light and canopy

GENERAL FEATURES

85 Lt. Countertop drink cooler	•
White coated steel for internal and external side	•
Roll-bond evaporator system with fan assisted cooling	•
Manual defrost	•
Foaming Agent Cyclopentane (45mm per side)	•
Mechanical thermostat	•
Digital Thermometer	•
Self closing door	•
Removable Gasket	•
Adjustable shelves: 6 Pcs	•
Independent switches for internal light and canopy	•
Toughened safety tempered glass	•
Lock fitted as standard	•
Inner LED light / Fluorescent for canopy	•
N.4 Adjustable feet	•

SIZES

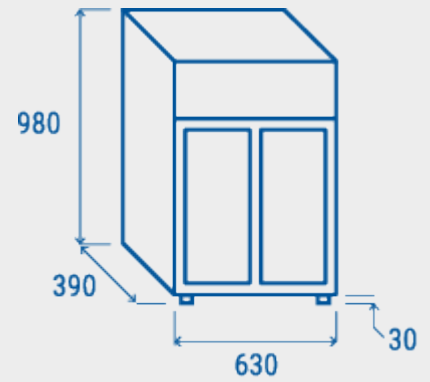

TECHNICAL SPECIFICATION

INNER DEPTH	230 mm
INNER HEIGHT	630 mm
INNER WIDTH	550 mm
DEPTH	390 mm
HEIGHT	980 mm
WIDTH	630 mm
KW/24H	0 Kw
CAPACITY	85 L
NOISE LEVEL	55 dB(A)
CONSUMPTION	160 W
NET WEIGHT	47 Kg
TEMPERATURE RANGE	+1° ~ +10°C

CERTIFICATIONS

