

DETAILS



1. Ventilated unit
2. Main switch, light switch and digital thermostat fitted as standard
3. Lock fitted as standard
4. Inner vertical LED light
5. Hot gas defrost system

GENERAL FEATURES

1080 Lt. Freezer upright (GLASS DOOR)	•
White coated steel for external and internal	•
Ventilated Cooling	•
Hot gas defrost system	•
Foaming Agent Cyclopentane (60mm per side - CFC Free)	•
Digital thermostat	•
Independent main switch	•
Inner vertical LED light (with independent switch)	•
Removable Gasket	•
Heaterd glass door with double safety tempered glass	•
Self closing door	•
Lock fitted as standard and external aluminium square handle	•
Adjustable shelves: 12 Pcs	•
Inner back spacer net	•
N.4 Wheels for easy positioning	•

SIZES

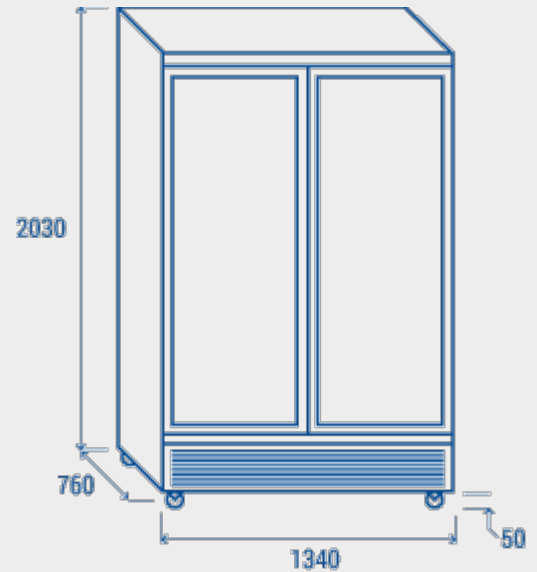

TECHNICAL SPECIFICATION

INNER DEPTH	580 mm
INNER HEIGHT	1535 mm
INNER WIDTH	1220 mm
DEPTH	760 mm
HEIGHT	2030 mm
WIDTH	1340 mm
KW/24H	25.8 Kw
CAPACITY	1080 L
NOISE LEVEL	65 dB(A)
CONSUMPTION	0 W
NET WEIGHT	252 Kg
TEMPERATURE RANGE	-18° ~ -22°C

CERTIFICATIONS

