

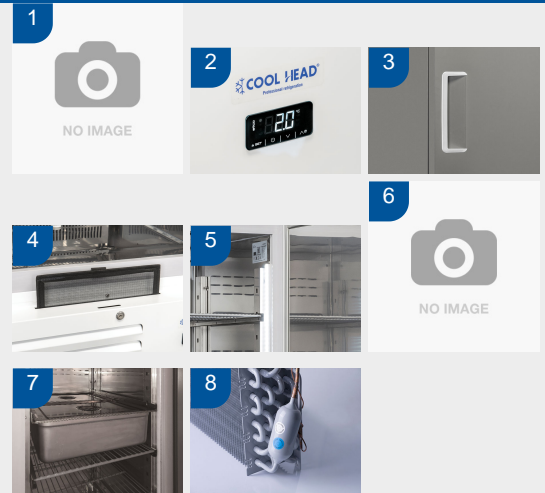

DETAILS



1. Evaporator with anti-corrosion treatment

GENERAL FEATURES

GN2/1 Refrigerated upright cabinet	•
Stainless Steel exterior and interior	•
Ventilated Cooling	•
Evaporator and condenser with anti-corrosion treatment	•
Bottom side engine room (for comformable storage goods in the chamber)	•
Hot gas defrost system	•
Digital thermostat with "opening door" and "Hi temperature" alarm	•
Foaming Agent Cyclopentane (80mm)	•
Removable Gasket	•
LED light and lock fitted as standard	•
Door: Self closing and reversible door fitted as standard	•
Adjustable shelves GN2/1: 5 Pcs	•
Plastic thermal-braker anti-condensation as chamber body frame	•
N.4 Adjustable feet - S/S feet or castor with brake (Option)	•

TECHNICAL SPECIFICATION

INNER DEPTH	710 mm
INNER HEIGHT	1430 mm
INNER WIDTH	580 mm
DEPTH	880 mm
HEIGHT	2025 mm
WIDTH	740 mm
KW/24H	1.55 Kw
CAPACITY	600 L
NOISE LEVEL	48 dB(A)
CONSUMPTION	210 W
NET WEIGHT	144 Kg
TEMPERATURE RANGE	-2° ~ +8°C

SIZES

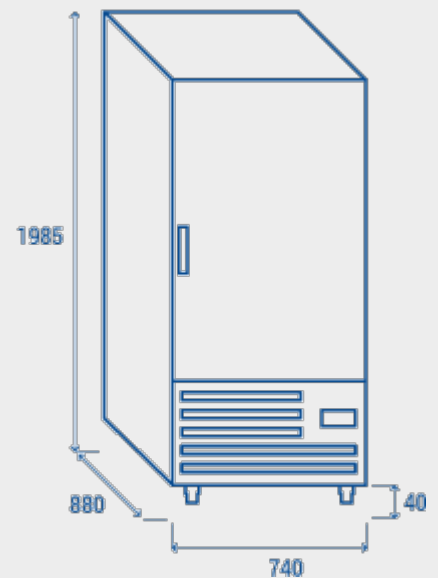

CERTIFICATIONS

