



DETAILS



1. Lock fitted as standard
2. Painted aluminium door frame with integrated handle

SIZES

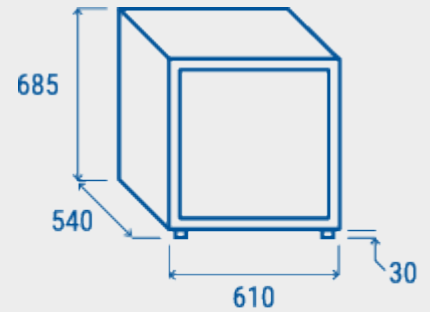

GENERAL FEATURES

90 Lt. Upright freezer	•
White coated steel for internal and external side	•
Static cooling	•
Manual defrost	•
Foaming Agent Cyclopentane (55mm per side)	•
Removable Gasket	•
Interior LED light	•
Triple heated safety tempered glass	•
Self closing door	•
Painted aluminium door frame with integrated handle	•
Lock fitted as standard	•
Adjustable shelves: 3 Pcs	•
N.4 Adjustable feet	•

TECHNICAL SPECIFICATION

INNER DEPTH	430 mm
INNER HEIGHT	540 mm
INNER WIDTH	500 mm
DEPTH	540 mm
HEIGHT	685 mm
WIDTH	610 mm
KW/24H	3.84 Kw
CAPACITY	90 L
NOISE LEVEL	45 dB
CONSUMPTION	213 W
NET WEIGHT	49 Kg
TEMPERATURE RANGE	-15°C ~ -20°C

CERTIFICATIONS

