



DETAILS



1. Lock fitted as standard
2. Painted aluminium door frame with integrated handle

SIZES

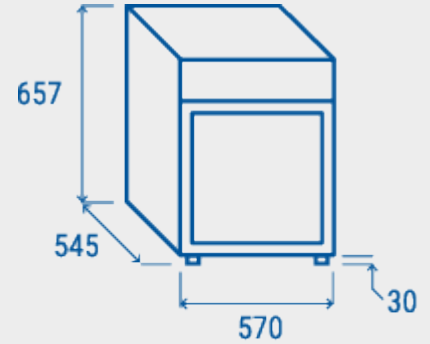

GENERAL FEATURES

50 Lt. Upright freezer with advertisement canopy	•
White coated steel for internal and external side	•
Static cooling	•
Manual defrost	•
Foaming Agent Cyclopentane (60mm per side)	•
Removable Gasket	•
Interior LED light / LED light for canopy	•
Triple heated safety tempered glass	•
Self closing door	•
Painted aluminium door frame with integrated handle	•
Lock fitted as standard	•
Adjustable shelves: 2	•
N.4 Adjustable feet	•

TECHNICAL SPECIFICATION

INNER DEPTH	420 mm
INNER HEIGHT	380 mm
INNER WIDTH	450 mm
DEPTH	545 mm
HEIGHT	657 mm
WIDTH	570 mm
KW/24H	2.17 Kw
CAPACITY	50 L
NOISE LEVEL	45 dB
CONSUMPTION	160 W
NET WEIGHT	42 Kg
TEMPERATURE RANGE	-15°C ~ -20°C

CERTIFICATIONS

