



**DETAILS**



1. Curved edge for easy cleaning
2. Engine room lock fitted as standard
3. Anti-condensation thermal-braker on door frame
4. Inner embossed door design for a better sealing
5. Sliding engine easy to pull out for manageable after sales servicing
6. Curved tempered glass with middle shelf
7. Inner assistance fan
8. Top view of the unit

**GENERAL FEATURES**

GN1/1 Refrigerated saladette (OPEN TOP)	•
Stainless Steel exterior and interior	•
Static cooling	•
Automatic compressor cycle defrost	•
Foaming Agent Cyclopentane (45mm per side)	•
Digital Thermostat	•
Sliding engine room for a manageable after sales servicing	•
Plastic thermal-braker as chamber body frame	•
Easy removable condenser filter	•
Separated plastic water tray	•
Front panel tilted holes for better air circulation	•
Adjustable shelves GN1/1: 2 Pcs	•
Self closing door (New inner embossed design for a better sealing)	•
Removable Gasket	•
Engine room lock fitted as standard	•
N.2 Adjustable feet in the front + N.4 fix rollers	•
Holder spacer for GN pans with "hook" design (included)	•

**TECHNICAL SPECIFICATION**

INNER DEPTH	586 mm
INNER HEIGHT	502 mm
INNER WIDTH	810 mm
DEPTH	700 mm
HEIGHT	1295 mm
WIDTH	900 mm
KW/24H	2.42 Kw
CAPACITY	232L
NOISE LEVEL	53.9 dB(A)
CONSUMPTION	142.4 W
NET WEIGHT	97 Kg
TEMPERATURE RANGE	+0° ~ +8°C

**SIZES**

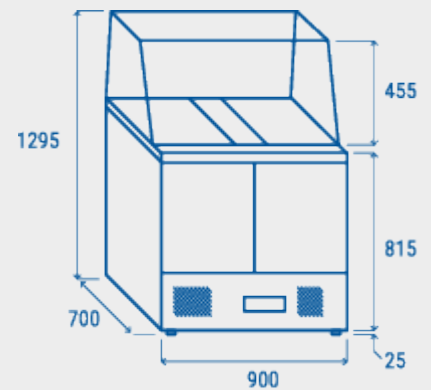

**CERTIFICATIONS**

