



DETAILS



1. Main switch, digital thermostat and door lock fitted as standard
2. Fixed evaporator shelves
3. Digital Thermostat
4. External cylindrical handle in stainless steel (Steel color for X Version)

GENERAL FEATURES

200 Lt. Freezer upright (GLASS DOOR)	•
S/S external cabinet, thermoformed internally	•
Static cooling: fixed evaporator shelves (N.3 Layers)	•
Manual defrost	•
Foaming Agent Cyclopentane (50mm per side)	•
Digital Thermostat	•
Removable Gasket	•
Lock and main switch fitted as standard	•
Stainless steel external handle	•
N.2 Adjustable feet + N.2 Rollers at the back	•
Triple heated safety tempered glass	•

SIZES

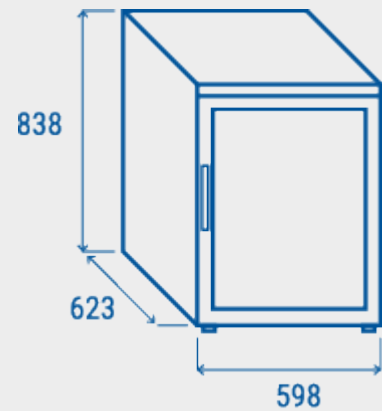

TECHNICAL SPECIFICATION

INNER DEPTH	477 mm
INNER HEIGHT	647 mm
INNER WIDTH	493 mm
DEPTH	670 mm
HEIGHT	838 mm
WIDTH	598 mm
KW/24H	2.15 Kw
CAPACITY	200 L
NOISE LEVEL	40 dB(A)
CONSUMPTION	174 W
NET WEIGHT	48 Kg
TEMPERATURE RANGE	-21°C ~ -18°C

CERTIFICATIONS

