



## DETAILS



1. The items can be supplied either with adjustable feet or lockable castor
2. Top horizontal LED light
3. Embossed rear shelf-stopper
4. Inner AISI 304 waved guides
5. "Door opening and Hi temperature alarm" as standard
6. Pressure valve for easily opening door
7. Evaporator with anti-corrosion treatment

## SIZES

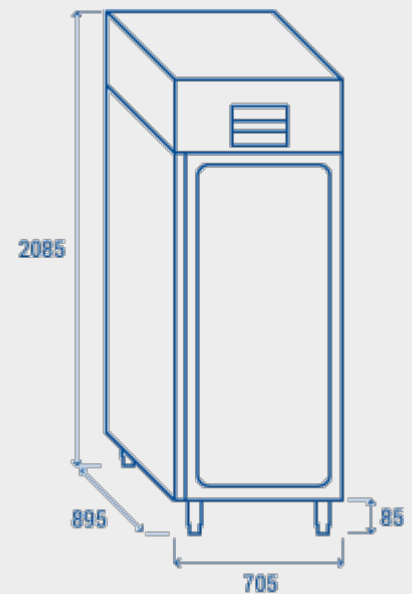

## GENERAL FEATURES

GN2/1 Freezer upright cabinet (GLASS DOOR)	•
Stainless Steel exterior and interior	•
Plastic thermal-braker as chamber body frame (Hot pipe system)	•
Inner with embossed rear shelf stopper and wave for easy cleaning	•
Ventilated Cooling	•
Evaporator with anti-corrosion treatment	•
Automatic defrost with electric heater	•
Foaming Agent Cyclopentane (85mm)	•
Digital thermostat with "opening door" and "Hi temperature" alarm	•
Removable Gasket	•
LED light and lock fitted as standard	•
Door: Self closing and heated glass (Not reversable)	•
Adjustable shelves GN2/1: 3 + 1	•
N.4 S/S Adjustable feet - (Lockable castor as Optional)	•

## TECHNICAL SPECIFICATION

INNER DEPTH	665 mm
INNER HEIGHT	1390 mm
INNER WIDTH	535 mm
DEPTH	895 mm
HEIGHT	2085 mm
WIDTH	705 mm
KW/24H	?? Kw
CAPACITY	550 L
NOISE LEVEL	62 dB(A)
CONSUMPTION	250 W
NET WEIGHT	163 Kg
TEMPERATURE RANGE	-15°C ~ -20°C

## CERTIFICATIONS

