

DETAILS



1. Main switch, digital thermostat and door lock fitted as standard
2. Digital Thermostat
3. External cylindrical handle in stainless steel (Steel color for X Version)
4. Inner assistance fan

GENERAL FEATURES

200 Lt. Refrigerated upright (GLASS DOOR)	•
White external cabinet, thermoformed internally	•
Roll-bond evaporator system with fan assisted cooling	•
Automatic compressor cycle defrost	•
Foaming Agent Cyclopentane (35mm per side)	•
Digital Thermostat	•
Removable Gasket	•
Inner LED light	•
Lock and main switch fitted as standard	•
Adjustable shelves: 2 Pcs	•
Stainless steel external handle	•
N.2 Adjustable feet + N.2 Rollers at the back	•

SIZES

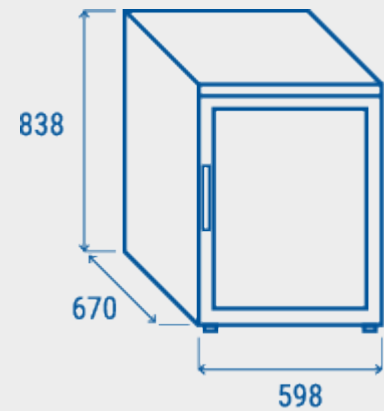

TECHNICAL SPECIFICATION

INNER DEPTH	482 mm
INNER HEIGHT	652 mm
INNER WIDTH	477 mm
DEPTH	670 mm
HEIGHT	838 mm
WIDTH	598 mm
KW/24H	0 Kw
CAPACITY	200 L
NOISE LEVEL	40 dB(A)
CONSUMPTION	130 W
NET WEIGHT	44 Kg
TEMPERATURE RANGE	+2°C ~ +8°C

CERTIFICATIONS

