



**DETAILS**



1. Curved edge for easy cleaning
2. Engine room lock fitted as standard
3. Anti-condensation thermal-breaker on door frame
4. Inner embossed door design for a better sealing
5. Sliding engine easy to pull out for manageable after sales servicing
6. Inner assistance fan

**GENERAL FEATURES**

GN1/1 Refrigerated saladette (STAINLESS STEEL TOP & DRAWERS)	•
Stainless Steel exterior and interior	•
Static cooling	•
Automatic compressor cycle defrost	•
Foaming Agent Cyclopentane (45mm per side)	•
Digital Thermostat	•
Sliding engine room for a manageable after sales servicing	•
Plastic thermal-breaker as chamber body frame	•
Easy removable condenser filter	•
Separated plastic water tray	•
Front panel tilted holes for better air circulation	•
Adjustable shelves GN1/1: 1 Pcs + N.2 Drawers (GN1/1)	•
Self closing door (New inner embossed design for a better sealing)	•
Removable Gasket	•
Engine room lock fitted as standard	•
N.2 Adjustable feet in the front + N.4 fix rollers	•

**SIZES**

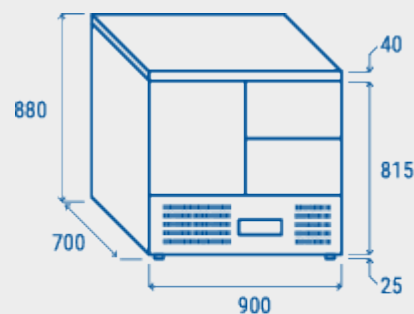

**TECHNICAL SPECIFICATION**

INNER DEPTH	586 mm
INNER HEIGHT	492 mm
INNER WIDTH	810 mm
DEPTH	700 mm
HEIGHT	880 mm
WIDTH	900 mm
KW/24H	2.1 Kw
CAPACITY	214L
NOISE LEVEL	50 dB(A)
CONSUMPTION	142.4 W
NET WEIGHT	88 Kg
TEMPERATURE RANGE	+0° ~ +8°C

**CERTIFICATIONS**

