



## DETAILS



1. The items can be supplied either with adjustable feet or lockable castor
2. Top horizontal LED light
3. Embossed rear shelf-stopper
4. Inner AISI 304 waved guides
5. "Door opening and Hi temperature alarm" as standard
6. Bottom hole for easily clean and dry the item
7. Evaporator with anti-corrosion treatment

## GENERAL FEATURES

GN2/1 Refrigerated upright cabinet (CLASS B)	•
Stainless Steel exterior and interior	•
Plastic thermal-braker anti-condensation as chamber body frame	•
Inner with embossed rear shelf stopper and wave for easy cleaning	•
Ventilated Cooling	•
Evaporator with anti-corrosion treatment	•
Automatic defrost with electric heater	•
Foaming Agent Cyclopentane (85mm)	•
Digital thermostat with "opening door" and "Hi temperature" alarm	•
Removable Gasket	•
LED light and lock fitted as standard	•
Door with self closing door	•
Adjustable shelves GN2/1: 6 + 2 + 3 middle	•
N.4 S/S Adjustable feet - (Lockable castor as Optional)	•

## TECHNICAL SPECIFICATION

INNER DEPTH	665 mm
INNER HEIGHT	1390 mm
INNER WIDTH	1260 mm
DEPTH	895 mm
HEIGHT	2085 mm
WIDTH	1430 mm
KW/24H	1.92 Kw
CAPACITY	1105 L
NOISE LEVEL	62 dB(A)
CONSUMPTION	240 W
NET WEIGHT	234 Kg
TEMPERATURE RANGE	-2°C ~ +8°C

## SIZES

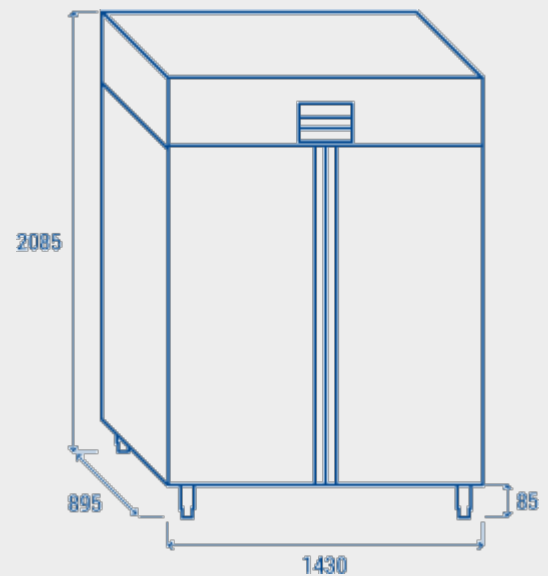

## CERTIFICATIONS

