



**DETAILS**



1. Curved edge for easy cleaning
2. Engine room lock fitted as standard
3. Anti-condensation thermal-breaker on door frame
4. Inner embossed door design for a better sealing
5. Sliding engine easy to pull out for manageable after sales servicing
6. Inner assistance fan
7. Door design

**GENERAL FEATURES**

|  |   |
|--|---|
| GN1/1 Refrigerated saladette (STAINLESS STEEL TOP)                 | • |
| Stainless Steel exterior and interior                              | • |
| Static cooling   | • |
| Automatic compressor cycle defrost                                 | • |
| Foaming Agent Cyclopentane (45mm per side)                         | • |
| Digital Thermostat   | • |
| Sliding engine room for a manageable after sales servicing         | • |
| Plastic thermal-breaker as chamber body frame                      | • |
| Easy removable condenser filter                                    | • |
| Separated plastic water tray                                       | • |
| Front panel tilted holes for better air circulation                | • |
| Adjustable shelves GN1/1: 2 Pcs                                    | • |
| Self closing door (New inner embossed design for a better sealing) | • |
| Removable Gasket   | • |
| Engine room lock fitted as standard                                | • |
| N.2 Adjustable feet in the front + N.4 fix rollers                 | • |
| Splash back height (100mm)   | • |

**TECHNICAL SPECIFICATION**

|                   |            |
|-------------------|------------|
| INNER DEPTH       | 585 mm     |
| INNER HEIGHT      | 492 mm     |
| INNER WIDTH       | 810 mm     |
| DEPTH             | 700 mm     |
| HEIGHT            | 980 mm     |
| WIDTH             | 900 mm     |
| KW/24H            | 2.2 Kw     |
| CAPACITY          | 214L       |
| NOISE LEVEL       | 50 dB(A)   |
| CONSUMPTION       | 142.4 W    |
| NET WEIGHT        | 90 Kg      |
| TEMPERATURE RANGE | +0° ~ +8°C |

**SIZES**

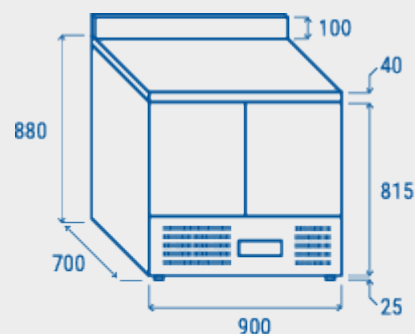

**CERTIFICATIONS**

