



DETAILS



1. The items can be supplied either with adjustable feet or lockable castor
2. Top horizontal LED light
3. Embossed rear shelf-stopper
4. Inner AISI 304 waved guides
5. Inverter compressor
6. "Door opening and Hi temperature alarm" as standard
7. Bottom hole for easily clean and dry the item
8. Evaporator with anti-corrosion treatment

GENERAL FEATURES

GN2/1 Refrigerated upright cabinet (CLASS A)	•
Stainless Steel exterior and interior	•
Plastic thermal-braker anti-condensation as chamber body frame	•
Inner with embossed rear shelf stopper and wave for easy cleaning	•
Ventilated Cooling	•
Evaporator with anti-corrosion treatment	•
Automatic defrost with electric heater	•
Foaming Agent Cyclopentane (85mm)	•
Digital thermostat with "opening door" and "Hi temperature" alarm	•
Removable Gasket	•
LED light and lock fitted as standard	•
Door with self closing door	•
Adjustable shelves GN2/1: 6 + 2 + 3 middle	•
N.4 S/S Adjustable feet - (Lockable castor as Optional)	•
Inverter compressor	•

TECHNICAL SPECIFICATION

INNER DEPTH	665 mm
INNER HEIGHT	1390 mm
INNER WIDTH	1260 mm
DEPTH	890 mm
HEIGHT	2085 mm
WIDTH	1430 mm
KW/24H	1.41 Kw
CAPACITY	1105 L
NOISE LEVEL	62 dB(A)
CONSUMPTION	200 W
NET WEIGHT	234 Kg
TEMPERATURE RANGE	-2°C ~ +8°C

SIZES

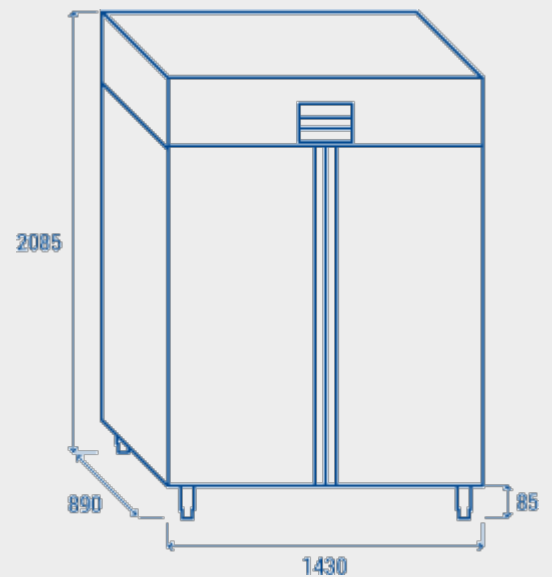

CERTIFICATIONS

