



DETAILS



- 1. Inner assistance fan
- 2. Lock fitted as standard

SIZES

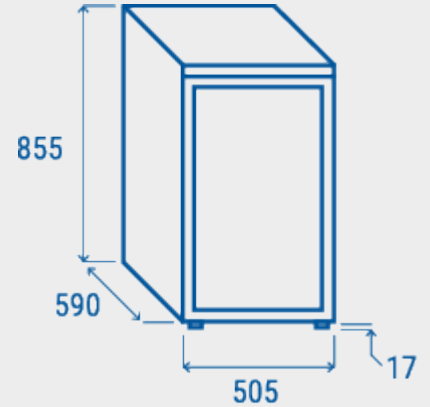

GENERAL FEATURES

115 Lt. Upright drink cooler	•
External in white coated plate, white thermoformed internally	•
Roll-bond evaporator system with fan assisted cooling	•
Manual defrost	•
Foaming Agent Cyclopentane (45mm per side)	•
Removable Gasket	•
Independent switch for internal light	•
Double layer safety tempered glass (Curved)	•
Digital thermometer	•
Reversible door	•
Lock fitted as standard	•
Adjustable shelves (White Color): 3 Pcs	•
N.4 Adjustable feet	•

TECHNICAL SPECIFICATION

INNER DEPTH	395 mm
INNER HEIGHT	700 mm
INNER WIDTH	410 mm
DEPTH	590 mm
HEIGHT	855 mm
WIDTH	505 mm
KW/24H	1.05 Kw
CAPACITY	115 L
NOISE LEVEL	47 dB(A)
CONSUMPTION	90 W
NET WEIGHT	37 Kg
TEMPERATURE RANGE	+4° ~ +10°C

CERTIFICATIONS

