

ESC

PARTIDO COMERCIAL SPLIT

COMMERCIAL SPLIT | SPLIT COMMERCIAL



Equipos frigoríficos partidos comerciales Split para cámaras frigoríficas de pequeño volumen en aplicaciones de media y baja temperatura.

Split commercial refrigeration equipment for cold storage rooms, which have a small volume, and for use in medium and low temperatures.

Équipements frigorifiques divisés commerciaux Split pour chambres frigorifiques de petit volume pour des applications de moyenne et basse température.

Características | Characteristics | Caractéristiques

U.M.

Modelo equipo / Equip model / Modèle		ESC4035M5G
Tª de trabajo / Working Tª / Tª Travail	°C	-5 / +10
Tensión / Voltage / Tension	V / Ph / Hz	400/3/50
I nominal / Nominal consumption / I nominal	A*	7,2
I max. absorbida / Maximum consumption / I max absorbé	A	11,1
Refrigerante / Refrigerant / Réfrigérant		R 455A
Carga de refrigerante / Refrigerant charge / Charge de réfrigérant	kg	5,5
PCA / GWP		148
Potencia Frig. / Cooling Power / Puissance	Tint. / Text.	0°C / 32°C
	W	6.010
Peso neto / Net weight / Poids net	kg	170
Categoría PED / PED category / Catégorie PED		Cat. II
Nivel sonoro / Noise level / Niveau sonore	EN-13487	dBA (10m) 45

Evaporador | Cooler | Evaporateur

U.M.

Modelo equipo / Equip model / Modèle		EEC2236M1G
Desescarche / Defrosting / Dégivrage	W	2.400
Válvula expansión / Expans. valve / Détendeur		TES2 /Nº4 SIN MOP
Potencia vent. / Fan power / Puissance vent.	Nº x W	2 x 250
Caudal / Flow / Débit d'air	m³ / h	9.600
Nº / Ø vent. / fan / vent.	Nº x mm	2 x 450
Dardo de aire / Air Throw / Jet d'air	m**	20
Conexiones frigoríficas / Pipelines	Liq. – Suct.	inches 1/2 – 7/8
Conexión de desagüe / Drain connection / Raccord de drainage	gas	1 1/4

* En condiciones nominales de trabajo / Nominal working conditions / Conditions de travail nominales

** Valor meramente indicativo / Indicative value only / Valeur indicative

Condensador | Condenser | Condenseur

U.M.

Potencia vent. / Fan power / Puissance vent.	Nº x W	1 x 250
Caudal / Flow / Débit d'air	m ³ / h	2.900
Nº / Ø vent. / fan / vent.	Nº x mm	1 x 450
Conexiones frigoríficas / Pipelines Liq. – Suct.	inches	1/2 – 3/4

Compresor | Compressor | Compresseur

Modelo / Model / Modèle	MLZ026T4B
Tipo / Type / Type	Hermético / Hermetic / Hermétique

Dimensiones | Dimensions | Dimensions

Condensador / Condenser / Condenseur				
A	B	C	D1	D2
665	670	1030	455	570

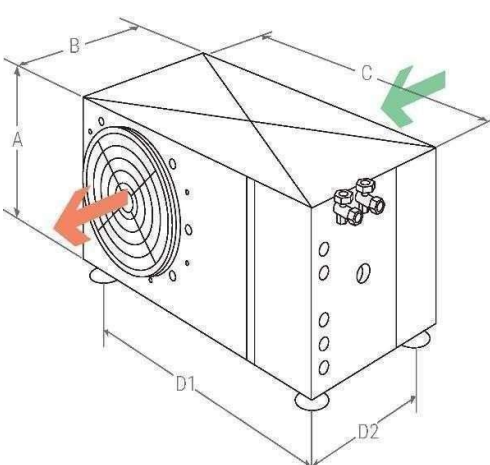

Evaporador / Cooler / Evaporateur				
A	B	C	D1	D2
580	570	1595	1325	465

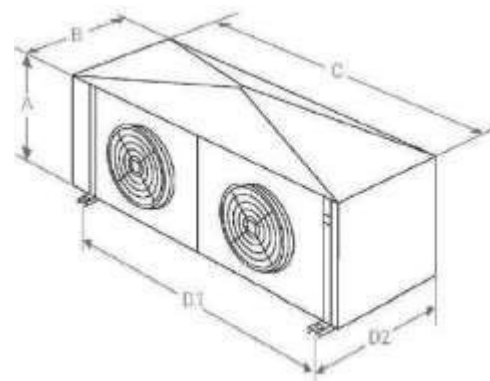

C.U. + EMB. / PACK.				EVAP. + EMB. / PACK.			
A	B	C	kg	A	B	C	kg
1125	740	1070	130	680	710	1780	82

