



new  
2020

**DETAILS**



1. Inner assistance fan

**SIZES**

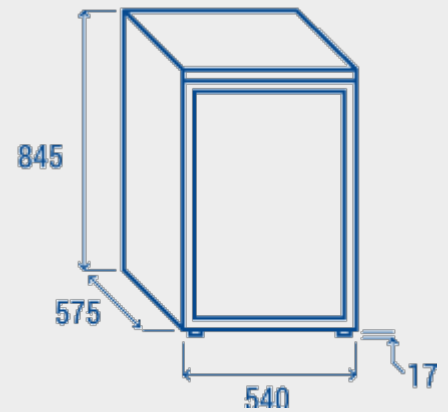

**GENERAL FEATURES**

130 Lt. Upright drink cooler	•
External in black coated plate, black aluminium internally	•
Roll-bond evaporator system with fan assisted cooling	•
Manual defrost	•
Foaming Agent Cyclopentane (50mm per side)	•
Removable Gasket	•
Independent switch for internal light	•
Double layer safety tempered glass (Curved)	•
Door: Self closing and reversible door fitted as standard	•
Adjustable chromed shelf (5 Pcs) and chromed basket (1 Pcs)	•
N.4 Adjustable feet	•
Customization available	•

**TECHNICAL SPECIFICATION**

INNER DEPTH	448 mm
INNER HEIGHT	723 mm
INNER WIDTH	420 mm
DEPTH	548 mm
HEIGHT	845 mm
WIDTH	540 mm
KW/24H	1.8 Kw
CAPACITY	130 L
NOISE LEVEL	39 dB(A)
CONSUMPTION	110 W
NET WEIGHT	30 Kg
TEMPERATURE RANGE	+0° ~ +10°C

**CERTIFICATIONS**

