



**DETAILS**



1. Inner assistance fan

**GENERAL FEATURES**

52 Lt. Upright drink cooler	•
External in black coated plate, black aluminium internally	•
Roll-bond evaporator system with fan assisted cooling	•
Manual defrost	•
Foaming Agent Cyclopentane (40mm per side)	•
Removable Gasket	•
Independent switch for internal light	•
Double layer safety tempered glass (Curved)	•
Door: Self closing and reversible door fitted as standard	•
Adjustable shelves (White Color): 2 Pcs	•
N.4 Adjustable feet	•

**SIZES**

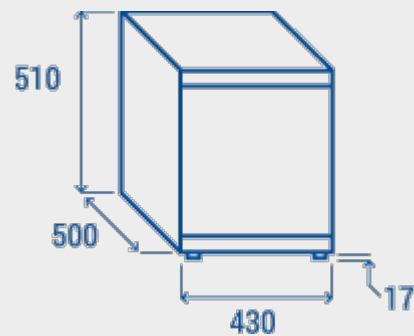

**TECHNICAL SPECIFICATION**

INNER DEPTH	370 mm
INNER HEIGHT	415 mm
INNER WIDTH	335 mm
DEPTH	500 mm
HEIGHT	510 mm
WIDTH	430 mm
KW/24H	1.2 Kw
CAPACITY	52 L
NOISE LEVEL	39 dB(A)
CONSUMPTION	85 W
NET WEIGHT	17 Kg
TEMPERATURE RANGE	+0° ~ +10°C

**CERTIFICATIONS**

