



DETAILS



1. Castor included in the packaging (To be assembled)
2. Lock fitted as standard
3. Digital control panel with alarm
4. Inner horizontal LED light (with independent switch)
5. Digital thermometer display
6. Basket included

GENERAL FEATURES

300 Lt. Chest freezer with sliding glass top	•
White coated steel for external and internal	•
Static cooling	•
Manual defrost	•
Digital thermometer	•
Foaming Agent Cyclopentane (70mm per side)	•
Single tempered safety glass	•
Handle on the glass frame	•
Lock fitted as standard	•
Inner horizontal LED light (with independent switch)	•
Basket included (N.3 Pcs)	•
N.4 Castor (N.2 in the front with brake)	•

SIZES

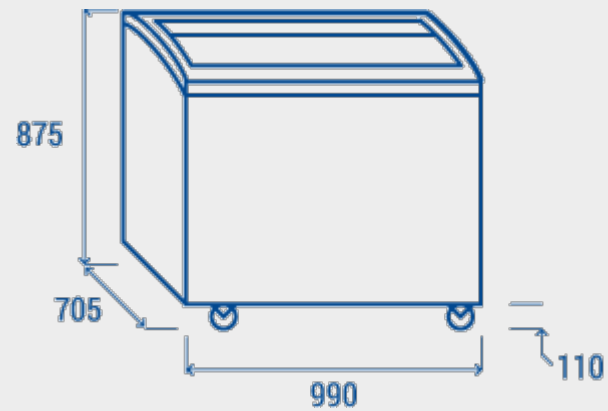

TECHNICAL SPECIFICATION

INNER DEPTH	540 mm
INNER HEIGHT	590 mm
INNER WIDTH	845 mm
DEPTH	705 mm
HEIGHT	875 mm
WIDTH	990 mm
KW/24H	2.97 Kw
CAPACITY	190 L
NOISE LEVEL	48 dB(A)
CONSUMPTION	164 W
NET WEIGHT	57 Kg
TEMPERATURE RANGE	-18° ~ -22°C

CERTIFICATIONS

