



DETAILS



GENERAL FEATURES

Ventilated refrigerated saladette (STAINLESS STEEL TOP with DRAWERS)	•
Stainless Steel exterior and interior	•
Ventilated Cooling	•
Automatic compressor cycle defrost	•
Foaming Agent Cyclopentane (50mm per side)	•
Sliding engine room for a manageable after sales servicing	•
Digital Thermostat with "Flat display" and temperature alarm	•
Opening door alarm	•
Plastic thermal-braker as chamber body frame	•
Easy removable condenser filter/Separated plastic water tray	•
N.2 Drawers (GN1/1) equipped with telescopic guides	•
N.2 Sliding drawers GN1/1 suitable for pans 150mm depth	•
Foamed door handle and removable gasket	•
Holder spacer for GN pans with "hook" design (included)	•
N.4 S/S Adjustable feet - (Lockable castor as Optional)	•

SIZES

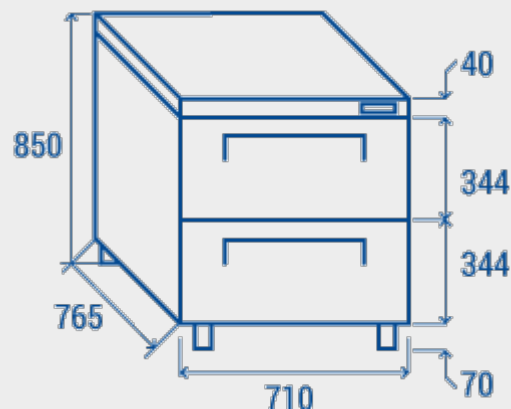

TECHNICAL SPECIFICATION

INNER DEPTH	565 mm
INNER HEIGHT	653 mm
INNER WIDTH	610 mm
DEPTH	765 mm
HEIGHT	850 mm
WIDTH	710 mm
KW/24H	1.23 Kw
CAPACITY	188 L
NOISE LEVEL	0 dB(A)
CONSUMPTION	108 W
NET WEIGHT	70 Kg
TEMPERATURE RANGE	0°C ~ +8°C

CERTIFICATIONS

