

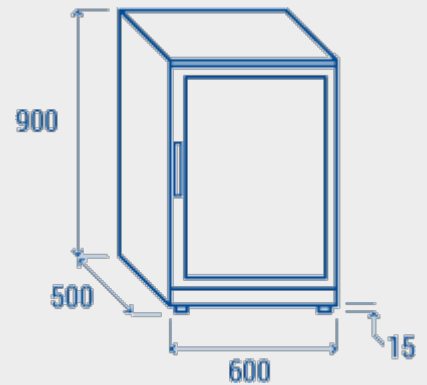

DETAILS



SIZES



GENERAL FEATURES

N.1 Hinged stainless steel door BACK BAR	•
Black coated steel for external side and mirror stainless steel for internal	•
Item with shiny finishing and total height at 900mm	•
Ventilated Cooling	•
Automatic compressor cycle defrost	•
Foaming Agent Cyclopentane (40mm per side)	•
Digital thermostat	•
Self closing door	•
Removable Gasket	•
Adjustable shelves: 2 Pcs	•
Toughened safety tempered glass with steel frame	•
Lock fitted as standard	•
Inner horizontal LED light	•
Independent switches: Main (Green Color) and inner LED light (Red Color)	•
N.4 Adjustable feet	•

TECHNICAL SPECIFICATION

INNER DEPTH	355 mm
INNER HEIGHT	745 mm
INNER WIDTH	510 mm
DEPTH	500 mm
HEIGHT	900 mm
WIDTH	600 mm
KW/24H	1 Kw
CAPACITY	138 L
NOISE LEVEL	55 dB(A)
CONSUMPTION	130 W
NET WEIGHT	44 Kg
TEMPERATURE RANGE	+1° ~ +10°C

CERTIFICATIONS

