



DETAILS



1. The items can be supplied either with adjustable feet or lockable castor
2. Digital control
3. Inner LED light
4. Shelf for salami
5. Humidity sensor
6. Suitable for salami/ham
7. Suitable for cheese
8. Cheese shelf set (N.4 Shelves) separately orderable

GENERAL FEATURES

Refrigerated curing meat upright (TROPICALIZED)	•
Stainless Steel exterior and interior	•
Ventilated Cooling	•
Hot gas defrost system	•
Foaming Agent Cyclopentane (75mm per side)	•
Digital thermostat	•
Removable Gasket	•
LED light and lock fitted as standard	•
Door: Self closing and reversible door fitted as standard	•
Automatic extractor for air re-oxygenating fitted as standard	•
Adjustable humidity at the percentage point (settable from 1%-99%)	•
N. 6 Salami shelves (with Hook) fitted as standard	•
N. 5 pre-set and customizable recipes/N.7 programmable steps for each recipe	•
N.6 S/S Adjustable feet - (Lockable castor as Optional)	•

TECHNICAL SPECIFICATION

INNER DEPTH	705 mm
INNER HEIGHT	1540 mm
INNER WIDTH	1350 mm
DEPTH	850 mm
HEIGHT	2115 mm
WIDTH	1500 mm
KW/24H	0 Kw
CAPACITY	1500 L
NOISE LEVEL	52 dB(A)
CONSUMPTION	1800 W
NET WEIGHT	295 Kg
TEMPERATURE RANGE	0° ~ +25°C

SIZES

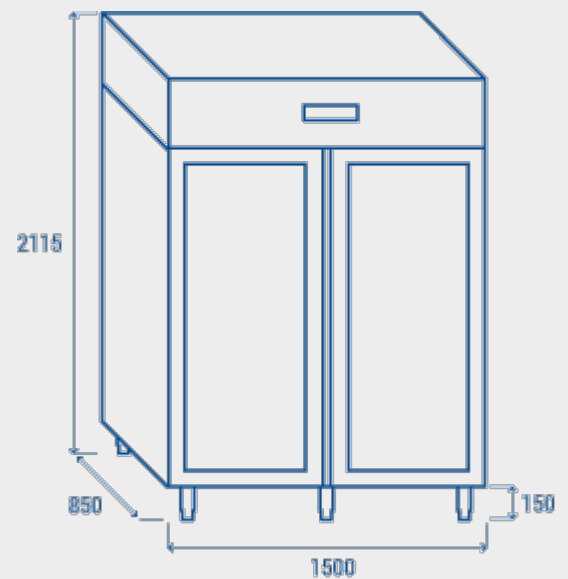

CERTIFICATIONS

