



**new
2020**

DETAILS



GENERAL FEATURES

40 Lt. Thermoelectric refrigerator	•
Static cooling with fan assisted cooling	•
Silent operation	•
Low vibrations	•
Low maintenance	•
Foaming Agent Cyclopentane (40mm per side - CFC Free)	•
Mechanical thermostat	•
Interior LED light	•
Lock fitted as standard	•
Door rack	•
Removable Gasket	•
Adjustable shelves: 1 Pcs	•
Handle along door profile	•
N.4 Adjustable feet	•

SIZES

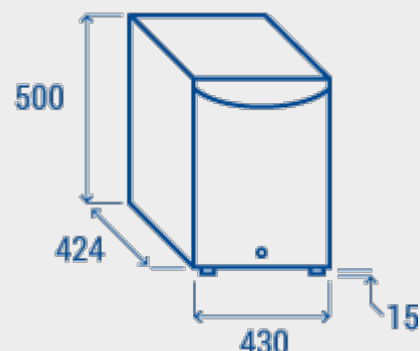

TECHNICAL SPECIFICATION

INNER DEPTH	266 mm
INNER HEIGHT	410 mm
INNER WIDTH	356 mm
DEPTH	424 mm
HEIGHT	515 mm
WIDTH	430 mm
KW/24H	0.49 Kw
CAPACITY	40 L
NOISE LEVEL	39 dB(A)
CONSUMPTION	60 W
NET WEIGHT	9 Kg
TEMPERATURE RANGE	+6° ~ +12°C

CERTIFICATIONS

