



DETAILS



1. Stainless steel basement
2. Double glass to reduce dispersion
3. Inner LED light

GENERAL FEATURES

160 Lt. Hot countertop showcase	•
Curve glass and stainless steel basement	•
Temperated glass with transparent frame	•
Mechanical thermostat	•
Analog thermometer	•
Interior LED light	•
Rear sliding doors	•
Adjustable chromed shelves (N.3 Pcs)	•
N.4 fix support assembled under the basement	•

SIZES

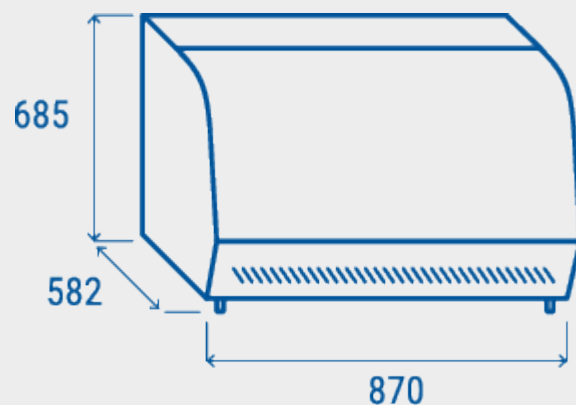

TECHNICAL SPECIFICATION

INNER DEPTH	505 mm
INNER HEIGHT	430 mm
INNER WIDTH	840 mm
DEPTH	582 mm
HEIGHT	685 mm
WIDTH	870 mm
KW/24H	N/A Kw
CAPACITY	0
NOISE LEVEL	13 dB(A)
CONSUMPTION	1500 W
NET WEIGHT	56 Kg
TEMPERATURE RANGE	+30° ~ +90°C

CERTIFICATIONS

