

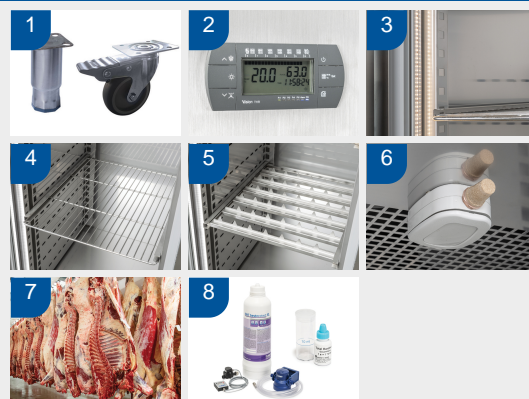

DETAILS



1. The items can be supplied either with adjustable feet or lockable castor
2. Digital control
3. Inner LED light
4. Reinforced shelves for meat
5. Shelf for salami
6. Humidity sensor
7. Suitable for sub primal cuts; as strip loins, rib eyes and sirloin
8. FDXL water filter kit with litres counter and tester included

GENERAL FEATURES

Refrigerated meat aging (TROPICALIZED)	•
Stainless Steel exterior and interior	•
Ventilated Cooling	•
Hot gas defrost system	•
Foaming Agent Cyclopentane (75mm per side)	•
Digital thermostat	•
Removable Gasket	•
LED light and lock fitted as standard	•
Door with self closing door	•
Automatic humidity generator (25%-85%)	•
Adjustable humidity at the percentage point (settable from 1%-99%)	•
Pipe for water connection and FDXL water filter included	•
N. 5 Meat shelves + N.1 Hook bar fitted as standard	•
N. 5 pre-set and customizable recipes/N.7 programmable steps for each recipe	•
N.6 S/S Adjustable feet - (Lockable castor as Optional)	•

TECHNICAL SPECIFICATION

INNER DEPTH	705 mm
INNER HEIGHT	1540 mm
INNER WIDTH	1350 mm
DEPTH	850 mm
HEIGHT	2115 mm
WIDTH	1500 mm
KW/24H	0 Kw
CAPACITY	1500 L
NOISE LEVEL	52 dB(A)
CONSUMPTION	1500 W
NET WEIGHT	295 Kg
TEMPERATURE RANGE	-2° ~ +5°C

SIZES

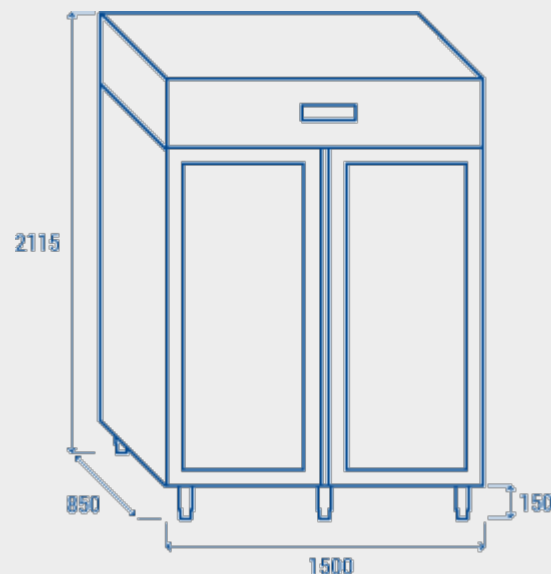

CERTIFICATIONS

