



DETAILS



GENERAL FEATURES

Wall showcase with hanging meat bar (Width: 1510mm)	•
External Egger laminate and black coated steel internally	•
Ventilated Cooling	•
Foaming Agent Cyclopentane (30mm per side - CFC Free)	•
Automatic compressor cycle defrost	•
Digital display control	•
Interior LED light (with independent switch)	•
Independent main switch	•
Adjustable shelves: 1 Pcs + hanging meat bar and 6 hooks	•
Panoramic ends providing the maximum visibility of the goods	•
Nightblind for an optimal energy conservation during nights (Fabric - Gray color)	•
Charcoal black bumper	•
N.4 Adjustable feet	•

SIZES

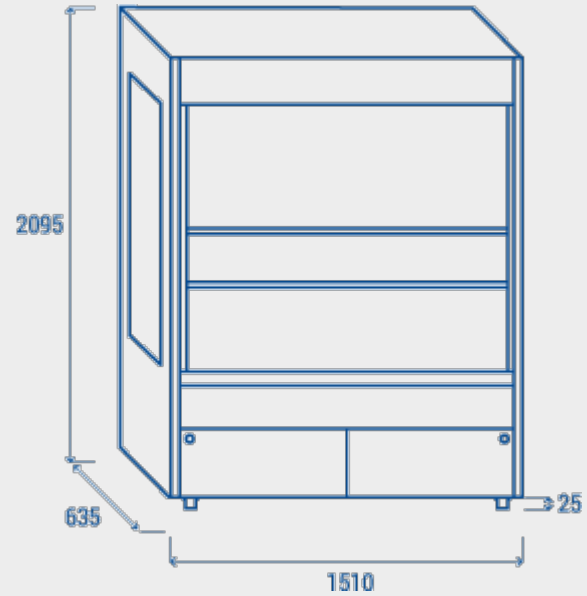

TECHNICAL SPECIFICATION

INNER DEPTH	540 mm
INNER HEIGHT	1167 mm
INNER WIDTH	1446 mm
DEPTH	635 mm
HEIGHT	2095 mm
WIDTH	1510 mm
KW/24H	24.7 Kw
CAPACITY	688 L
NOISE LEVEL	60 dB(A)
CONSUMPTION	1405 W
NET WEIGHT	244 Kg
TEMPERATURE RANGE	0° ~ +2°C

CERTIFICATIONS

