



DETAILS



GENERAL FEATURES

Ventilated refrigerated saladette (STAINLESS STEEL TOP)	•
Stainless Steel exterior and interior	•
Ventilated Cooling	•
Automatic compressor cycle defrost	•
Foaming Agent Cyclopentane (50mm per side)	•
Sliding engine room for a manageable after sales servicing	•
Digital Thermostat with "Flat display" and temperature alarm	•
Opening door alarm	•
Plastic thermal-braker as chamber body frame	•
Easy removable condenser filter/Separated plastic water tray	•
Adjustable shelves: 1 middle + 1 bottom (With anti-tipping system)	•
Self closing door (New inner embossed design for a better sealing)	•
Foamed door handle and removable gasket	•
N.4 S/S Adjustable feet - (Lockable castor as Optional)	•

SIZES

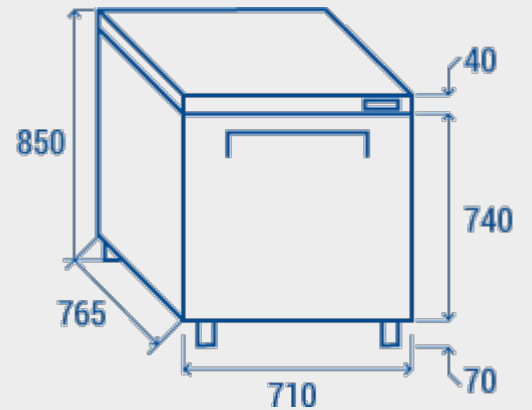

TECHNICAL SPECIFICATION

INNER DEPTH	565 mm
INNER HEIGHT	653 mm
INNER WIDTH	610 mm
DEPTH	765 mm
HEIGHT	850 mm
WIDTH	710 mm
KW/24H	1.21 Kw
CAPACITY	191 L
NOISE LEVEL	0 dB(A)
CONSUMPTION	108 W
NET WEIGHT	60 Kg
TEMPERATURE RANGE	0°C ~ +8°C

CERTIFICATIONS

