

DETAILS



1. Items suitable for refrigerated topping unit (VRX 14/33 and VRX 14/38)
2. Digital thermometer display
3. Handle with lock
4. Basket included
5. Inner LED light

GENERAL FEATURES

400 Lt. Chest cooler with standard top	•
White coated steel for external, embossed aluminium internally	•
Static cooling	•
Manual defrost	•
Defrost water drain	•
Foaming Agent Cyclopentane (60mm per side)	•
Removable Gasket	•
Interior LED light	•
Handle with lock	•
Digital thermometer display	•
Basket included (N.3 Pcs)	•
N.4 Castor (N.2 in the front with brake)	•

905

TECHNICAL SPECIFICATION

INNER DEPTH	510 mm
INNER HEIGHT	682 mm
INNER WIDTH	1430 mm
DEPTH	715 mm
HEIGHT	905 mm
WIDTH	1550 mm
KW/24H	2.43 Kw
CAPACITY	492 L
NOISE LEVEL	48.7 dB(A)
CONSUMPTION	135 W
NET WEIGHT	76 Kg
TEMPERATURE RANGE	+1° ~ +10°C

SIZES

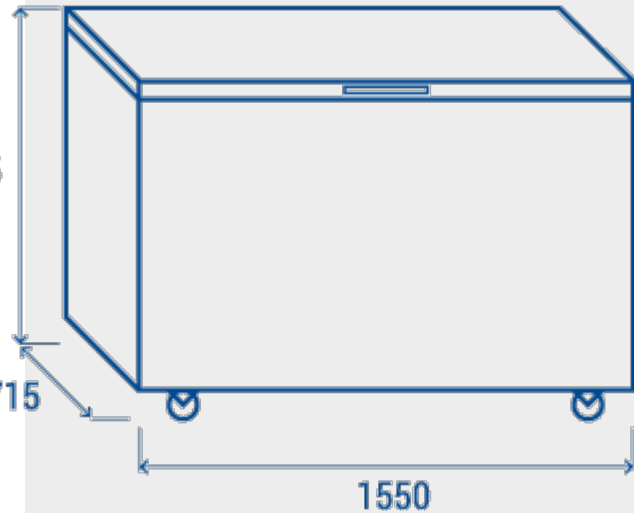

CERTIFICATIONS

