

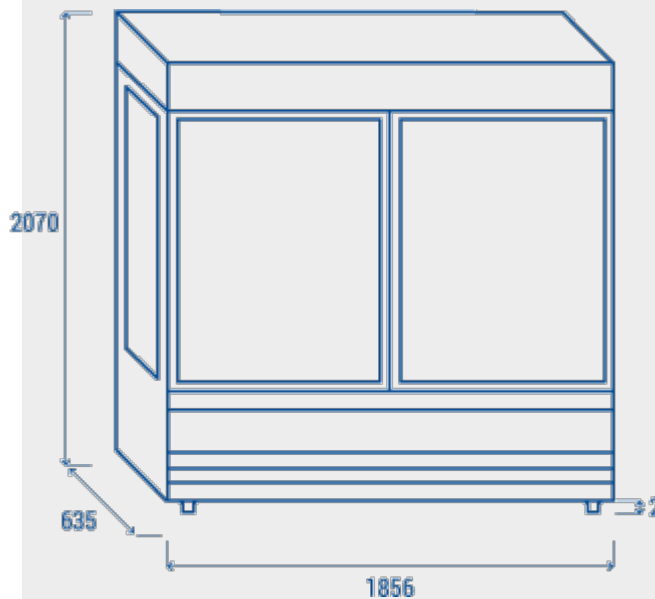

DETAILS



SIZES



GENERAL FEATURES

| | |
|--|---|
| Wall showcase with sliding doors (Width: 1856mm) | • |
| Black coated steel for internal and external side | • |
| Ventilated Cooling | • |
| Foaming Agent Cyclopentane (30mm per side - CFC Free) | • |
| Automatic compressor cycle defrost | • |
| Digital display control | • |
| Interior LED light | • |
| Anti-condensation double layer glass | • |
| Adjustable shelves: 5 Pcs | • |
| Panoramic ends providing the maximum visibility of the goods | • |
| Aluminium end trims and front panel | • |
| Charcoal black bumper | • |
| N.4 Adjustable feet | • |

TECHNICAL SPECIFICATION

| | |
|-------------------|-----------|
| INNER DEPTH | 540 mm |
| INNER HEIGHT | 1168 mm |
| INNER WIDTH | 1792 mm |
| DEPTH | 635 mm |
| HEIGHT | 2095 mm |
| WIDTH | 1856 mm |
| KW/24H | 15.1 Kw |
| CAPACITY | 1018 L |
| NOISE LEVEL | 58 dB(A) |
| CONSUMPTION | 1649 W |
| NET WEIGHT | 311 Kg |
| TEMPERATURE RANGE | 0° ~ +2°C |

CERTIFICATIONS

