



## DETAILS



## GENERAL FEATURES

|  |   |
|--|---|
| GN2/1 Freezer upright cabinet  | • |
| Gray coated steel for external side and stainless steel for inner side | • |
| Static cooling system with fan assisted cooling                        | • |
| Condenser with anti-corrosion treatment                                | • |
| Bottom side engine room (for comformable storage goods in the chamber) | • |
| Manual Defrost   | • |
| Digital thermostat with "opening door" and "Hi temperature" alarm      | • |
| Foaming Agent Cyclopentane (80mm)                                      | • |
| Removable Gasket   | • |
| LED light and lock fitted as standard                                  | • |
| Door: Self closing and reversible door fitted as standard              | • |
| Adjustable shelves GN2/1: 9 Pcs + 1 Pcs Bottom                         | • |
| Plastic thermal-braker as chamber body frame (Hot pipe system)         | • |
| GN 1/3 Ice cream pans (150mm - Depth) capacity: 46 pcs                 | • |
| 360x165x120mm Ice cream pans (5 Litres) capacity: 58 pcs               | • |
| N.4 Adjustable feet / Castor with brake (Option)                       | • |

## TECHNICAL SPECIFICATION

|                   |              |
|-------------------|--------------|
| INNER DEPTH       | 710 mm       |
| INNER HEIGHT      | 1430 mm      |
| INNER WIDTH       | 580 mm       |
| DEPTH             | 880 mm       |
| HEIGHT            | 2025 mm      |
| WIDTH             | 740 mm       |
| KW/24H            | 6.38 Kw      |
| CAPACITY          | 600 L        |
| NOISE LEVEL       | 48 dB(A)     |
| CONSUMPTION       | 324 W        |
| NET WEIGHT        | 150 Kg       |
| TEMPERATURE RANGE | -18° ~ -25°C |

## SIZES

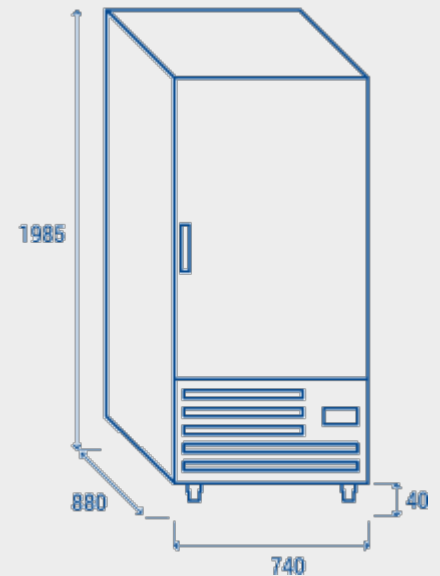

## CERTIFICATIONS

