

DETAILS



1. Items suitable for refrigerated topping unit (VRX 14/33 and VRX 14/38)
2. Digital thermometer display
3. Handle with lock
4. Basket included
5. Inner LED light

GENERAL FEATURES

| | |
|--|---|
| 300 Lt. Chest cooler with standard top | • |
| White coated steel for external, embossed aluminium internally | • |
| Static cooling | • |
| Manual defrost | • |
| Defrost water drain | • |
| Foaming Agent Cyclopentane (60mm per side) | • |
| Removable Gasket | • |
| Interior LED light | • |
| Handle with lock | • |
| Digital thermometer display | • |
| Basket included (N.3 Pcs) | • |
| N.4 Castor (N.2 in the front with brake) | • |

TECHNICAL SPECIFICATION

| | |
|-------------------|-------------|
| INNER DEPTH | 510 mm |
| INNER HEIGHT | 682 mm |
| INNER WIDTH | 890 mm |
| DEPTH | 715 mm |
| HEIGHT | 905 mm |
| WIDTH | 1015 mm |
| KW/24H | 1.75 Kw |
| CAPACITY | 290 L |
| NOISE LEVEL | 48.7 dB(A) |
| CONSUMPTION | 105 W |
| NET WEIGHT | 59 Kg |
| TEMPERATURE RANGE | +1° ~ +10°C |

SIZES

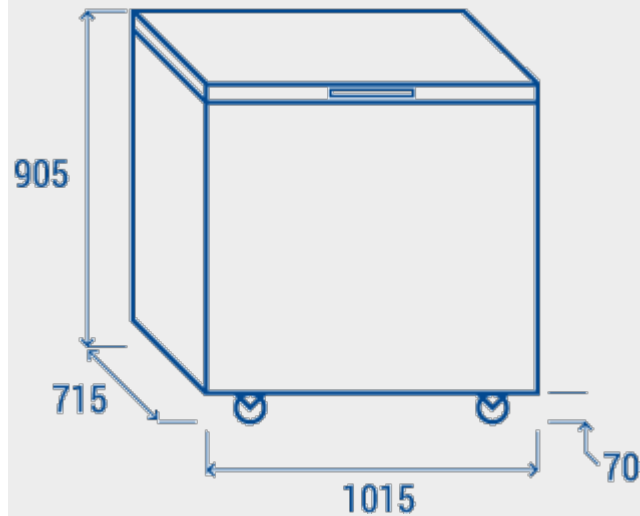

CERTIFICATIONS

