



## DETAILS



1. The items can be supplied either with adjustable feet or lockable castor
2. Top horizontal LED light
3. "Door opening and Hi temperature alarm" as standard
4. Pressure valve for easily opening door
5. Evaporator with anti-corrosion treatment

## GENERAL FEATURES

EURONORM Freezer upright cabinet	•
Stainless Steel exterior and interior	•
Plastic thermal-braker as chamber body frame (Hot pipe system)	•
Ventilated Cooling	•
Evaporator with anti-corrosion treatment	•
Automatic defrost with electric heater	•
Foaming Agent Cyclopentane (85mm)	•
Digital thermostat with "opening door" and "Hi temperature" alarm	•
Removable Gasket	•
LED light and lock fitted as standard	•
Door with self closing door	•
Set of 20 slides for bakery tray 600X400	•
N.4 S/S Adjustable feet - (Lockable castor as Optional)	•

## TECHNICAL SPECIFICATION

INNER DEPTH	665 mm
INNER HEIGHT	1390 mm
INNER WIDTH	1260 mm
DEPTH	895 mm
HEIGHT	2085 mm
WIDTH	1430 mm
KW/24H	8.23 Kw
CAPACITY	1105 L
NOISE LEVEL	62 dB(A)
CONSUMPTION	370 W
NET WEIGHT	257 Kg
TEMPERATURE RANGE	-18°C ~ -22°C

## SIZES

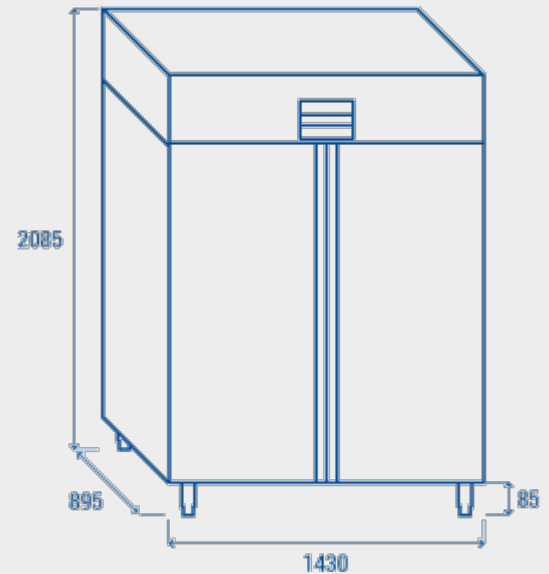

## CERTIFICATIONS

