

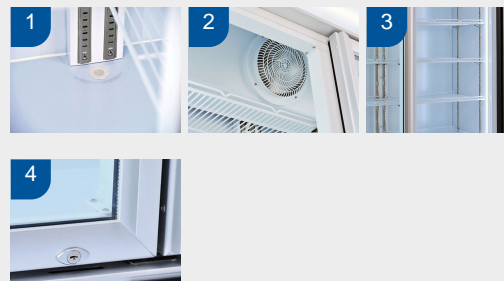

DETAILS



1. Bottom hole for easily clean and dry the item
2. Ventilated unit
3. Inner LED light
4. Lock fitted as standard

GENERAL FEATURES

1050 Lt. Total view drink cooler with advertising panel	•
White coated steel for internal and external side	•
Ventilated Cooling	•
Automatic compressor cycle defrost	•
Foaming Agent Cyclopentane (45mm per side)	•
Digital Thermostat	•
Removable Gasket	•
Independent switch for internal light and canopy	•
Toughened safety glass	•
Anti-condensation double layer glass	•
Self closing door and lock fitted as a standard	•
Adjustable shelves: 10 Pcs	•
Adjustable shelves (N.10 shelf)	•
N.4 Wheels for easy positioning + N.2 feet anti-tilted	•

TECHNICAL SPECIFICATION

INNER DEPTH	460 mm
INNER HEIGHT	1755 mm
INNER WIDTH	1025 mm
DEPTH	595 mm
HEIGHT	1975 mm
WIDTH	1120 mm
KW/24H	5.8 Kw
CAPACITY	1050 L
NOISE LEVEL	58 dB(A)
CONSUMPTION	475 W
NET WEIGHT	130 Kg
TEMPERATURE RANGE	+1° ~ +10°C

SIZES

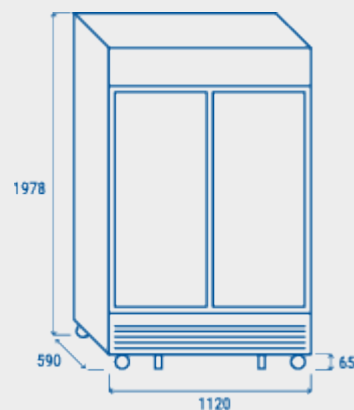

CERTIFICATIONS

