

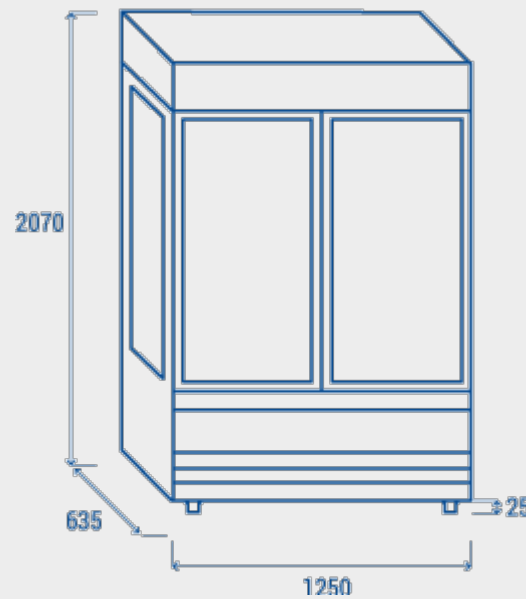

DETAILS



SIZES



GENERAL FEATURES

Wall showcase with sliding doors (Width: 1250mm)	•
Black coated steel for internal and external side	•
Ventilated Cooling	•
Foaming Agent Cyclopentane (30mm per side - CFC Free)	•
Automatic compressor cycle defrost	•
Digital display control	•
Interior LED light	•
Anti-condensation double layer glass	•
Adjustable shelves: 5 Pcs	•
Panoramic ends providing the maximum visibility of the goods	•
Aluminium end trims and front panel	•
Charcoal black bumper	•
N.4 Adjustable feet	•

TECHNICAL SPECIFICATION

INNER DEPTH	540 mm
INNER HEIGHT	1405 mm
INNER WIDTH	1186 mm
DEPTH	635 mm
HEIGHT	2095 mm
WIDTH	1250 mm
KW/24H	11.2 Kw
CAPACITY	673 L
NOISE LEVEL	55 dB(A)
CONSUMPTION	888 W
NET WEIGHT	234 Kg
TEMPERATURE RANGE	0° ~ +2°C

CERTIFICATIONS

