



**DETAILS**



1. Led LED light (BLUE Color)
2. Digital control
3. Sliding wooden shelves
4. Wood shelves

**GENERAL FEATURES**

130 Lt. Wine cellar free-standing installation	•
External in black coated plate, black thermoformed internally	•
Ventilated Cooling	•
Automatic compressor cycle defrost	•
Foaming Agent Cyclopentane (30mm per side)	•
Digital display control	•
Low temperature compensation function	•
Removable Gasket	•
Interior LED light (Blue Color)	•
Reversible door with vertical cylindrical handle	•
Lock and N.1 charcoal filterfitted as standard	•
Opening door alarm	•
Duoble layer safety temperated glass	•
Tinted glass door for wine protection	•
Adjustable wooden shelves: 4 Pcs + N.1 Bottom	•
N.4 Adjustable feet	•

**SIZES**

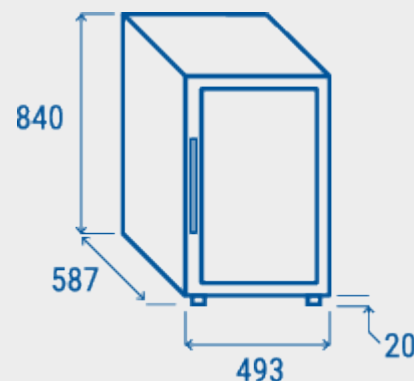

**TECHNICAL SPECIFICATION**

INNER DEPTH	436 mm
INNER HEIGHT	263 mm
INNER WIDTH	422 mm
DEPTH	587 mm
HEIGHT	840 mm
WIDTH	493 mm
KW/24H	0.54 Kw
CAPACITY	130 L
NOISE LEVEL	44 dB
CONSUMPTION	87 W
NET WEIGHT	41 Kg
TEMPERATURE RANGE	+5°~+10°C/+10°~+18°C

**CERTIFICATIONS**

