

DETAILS



1. Led LED light (BLUE Color)
2. Digital control
3. Sliding wooden shelves

GENERAL FEATURES

100 Lt. Wine cellar with built-in installation	•
External in black coated plate, black thermoformed internally	•
Ventilated Cooling	•
Automatic compressor cycle defrost	•
Foaming Agent Cyclopentane (30mm per side)	•
Digital display control	•
Low energy consumption	•
Removable Gasket	•
Interior LED light (Blue Color)	•
Reversible door with vertical cylindrical handle	•
Lock and N.1 charcoal filterfitted as standard	•
Opening door alarm	•
Duoble layer safety temperated glass	•
Tinted glass door for wine protection	•
Adjustable wooden shelves (N.6 pcs)	•
N.4 Adjustable feet	•

SIZES

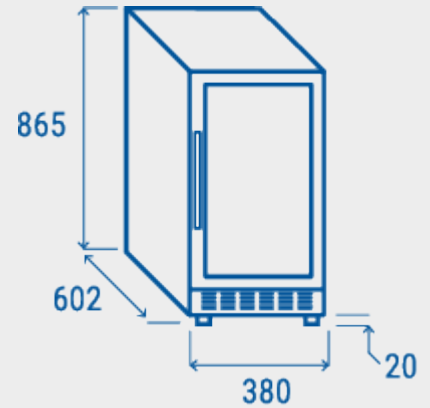

TECHNICAL SPECIFICATION

INNER DEPTH	453 mm
INNER HEIGHT	660 mm
INNER WIDTH	310 mm
DEPTH	602 mm
HEIGHT	865 mm
WIDTH	380 mm
KW/24H	0.39 Kw
CAPACITY	100 L
NOISE LEVEL	43 dB
CONSUMPTION	85 W
NET WEIGHT	35 Kg
TEMPERATURE RANGE	+5° ~ +18°C

CERTIFICATIONS

