



DETAILS



1. Independent light switches for inner light and canopy
2. Digital Thermostat
3. Inner vertical LED light
4. Lock fitted as standard

GENERAL FEATURES

1000 Lt. Upright drink cooler	•
White coated steel for internal and external side	•
Ventilated Cooling	•
Automatic compressor cycle defrost	•
Foaming Agent Cyclopentane (45mm per side)	•
Digital thermostat	•
Self closing door	•
Removable Gasket	•
Adjustable shelves: 8 Pcs	•
Independent switches for internal light and canopy	•
Toughened safety tempered glass	•
Lock fitted as standard	•
Inner vertical LED light / LED for canopy	•
N.4 Wheels for easy positioning	•

SIZES

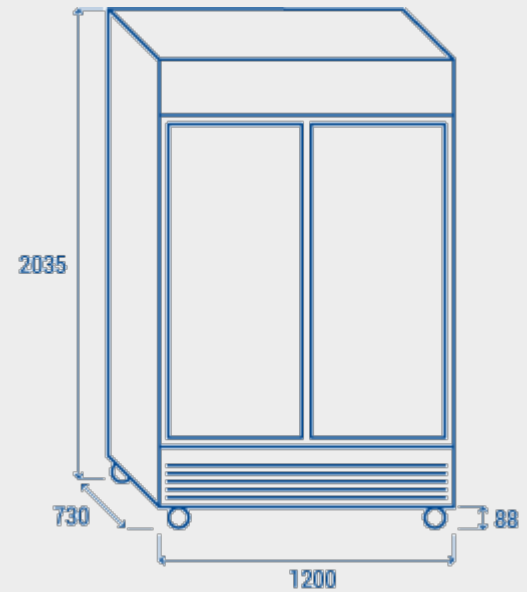

TECHNICAL SPECIFICATION

INNER DEPTH	595 mm
INNER HEIGHT	1525 mm
INNER WIDTH	1110 mm
DEPTH	730 mm
HEIGHT	2035 mm
WIDTH	1200 mm
KW/24H	6.05 Kw
CAPACITY	1000 L
NOISE LEVEL	64 dB(A)
CONSUMPTION	500 W
NET WEIGHT	158 Kg
TEMPERATURE RANGE	+1° ~ +10°C

CERTIFICATIONS

