

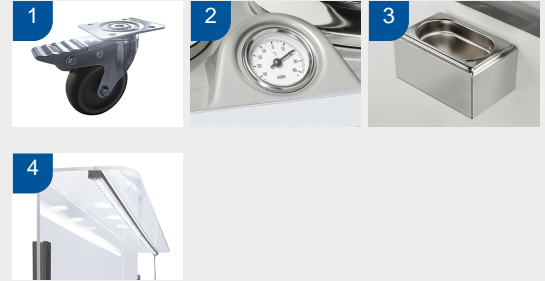

DETAILS



1. Castor included in the packaging (To be assembled)
2. Analogic thermometer
3. Scoop cleaner in stainless steel
4. LED light assembled on the plexiglass (Optional)

GENERAL FEATURES

300 Lt. Ice cream scooping cabinet	•
White coated steel for external and internal	•
Static cooling	•
Manual defrost	•
Digital thermometer	•
Analog thermometer	•
Foaming Agent Cyclopentane (60mm per side)	•
Service plan in plexiglass	•
Scoop cleaner in stainless steel fitted as standard	•
Taste/Price advertisement fitted as standard	•
Lid included (6 Pcs) / Pans not included	•
LED light assembled on the plexiglass (Optional)	•
N.4 Castor (N.2 in the front with brake)	•

TECHNICAL SPECIFICATION

INNER DEPTH	560 mm
INNER HEIGHT	565 mm
INNER WIDTH	785 mm
DEPTH	685 mm
HEIGHT	1240 mm
WIDTH	985 mm
KW/24H	2.49 Kw
CAPACITY	256 L
NOISE LEVEL	45 dB(A)
CONSUMPTION	271 W
NET WEIGHT	56 Kg
TEMPERATURE RANGE	-5° ~ -20°C

SIZES

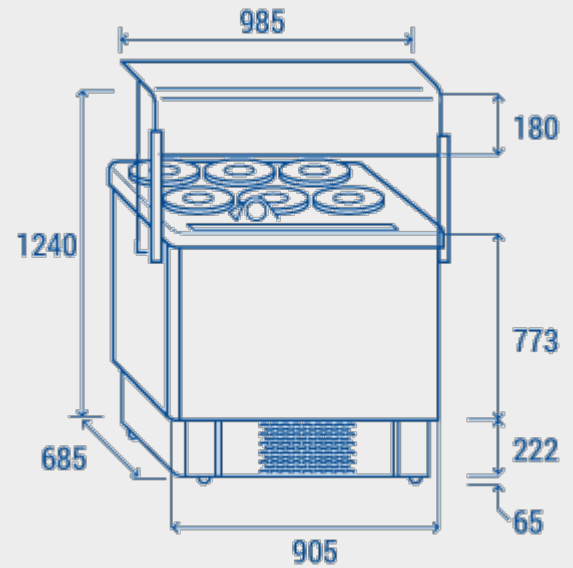

CERTIFICATIONS

