



DETAILS



1. Evaporator with anti-corrosion treatment

GENERAL FEATURES

GN1/1 and EURONORM 600x400mm Upright Blast chiller	•
Surface easy to clean (Anti-fing printing)	•
Ventilated Cooling with Manual defrost	•
Evaporator with anti-corrosion treatment	•
Foaming Agent Cyclopentane (70mm per side - CFC Free)	•
Digital Thermostat with Buzzer alarm	•
Error message directly in the display	•
Chilling chamber is AISI 304 steel type	•
Door microswitch for stop inner fan with open door	•
Separated water tray for collect condensation	•
Reversible door	•
Core probe fitted as standard	•
H.A.C.C.P. Traceability comply	•
USB Port for download data and 5 languages display info	•
N.4 Adjustable stainless steel feet	•

SIZES

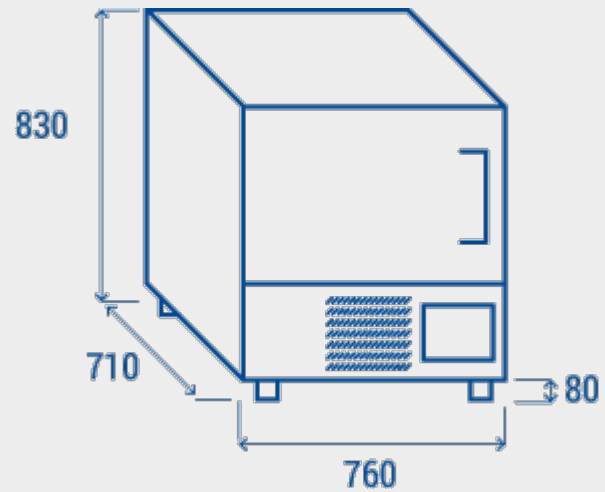

TECHNICAL SPECIFICATION

INNER DEPTH	420 mm
INNER HEIGHT	380 mm
INNER WIDTH	640 mm
DEPTH	710 mm
HEIGHT	830 mm
WIDTH	760 mm
KW/24H	N/A Kw
CAPACITY	0
NOISE LEVEL	55 dB(A)
CONSUMPTION	449 W
NET WEIGHT	103 Kg
TEMPERATURE RANGE	+10°C ~ -40°C

CERTIFICATIONS

