

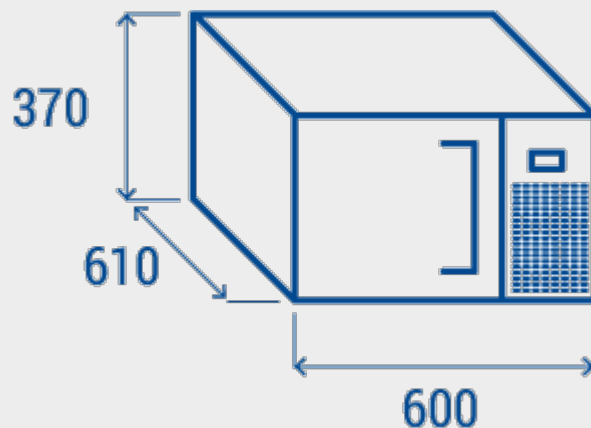

DETAILS

SIZES



GENERAL FEATURES

GN2/3 Counter top Blast chiller	•
Surface easy to clean (Anti-fing printing)	•
Ventilated Cooling with Manual defrost	•
Foaming Agent Cyclopentane (70mm per side - CFC Free)	•
Digital Thermostat with Buzzer alarm	•
Error message directly in the display	•
Chilling chamber is AISI 304 steel type	•
Door microswitch for stop inner fan with open door	•
Separated water tray for collect condensation	•
Reversible door	•
Core probe fitted as standard	•

TECHNICAL SPECIFICATION

INNER DEPTH	367 mm
INNER HEIGHT	270 mm
INNER WIDTH	345 mm
DEPTH	610 mm
HEIGHT	370 mm
WIDTH	600 mm
KW/24H	N/A Kw
CAPACITY	0
NOISE LEVEL	50 dB(A)
CONSUMPTION	218 W
NET WEIGHT	48 Kg
TEMPERATURE RANGE	+45° ~ -18°C

CERTIFICATIONS

