

## Technical specifications

### MTL60 (Mesh Tray Light)

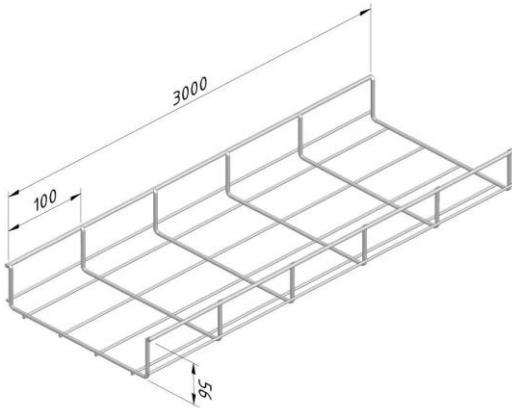

Finishing:		Ultra galva						
Product	Number	Height (mm)	Width (mm)	Length (mm)	Dim A (mm)	Fmax (kN)	Unit	Packaging (unit)
MTL60-100-3UG	16979	60	100	3000	100		M	3
MTL60-200-3UG	16980	60	200	3000	200		M	3
MTL60-300-3UG	16981	60	300	3000	300		M	3

Finishing:		Electro galvanized						
Product	Number	Height (mm)	Width (mm)	Length (mm)	Dim A (mm)	Fmax (kN)	Unit	Packaging (unit)
MTL60-100-3EG	14148	60	100	3000	100		M	3
MTL60-200-3EG	14158	60	200	3000	200		M	3
MTL60-300-3EG	14163	60	300	3000	300		M	3

MTL60-300-3CO	14162	60	300	3000	300	M	3
---------------	-------	----	-----	------	-----	---	---

#### Mounting instructions:

-

#### Load capacity:

Standard: -

Max. load: -

Load diagram: -

#### Information:

Coupler: MT60-JCL

Equipotential bonding: IEC61537

EC declaration: EC directive 2014/35/EU (Low voltage) as modified by directive 93/68/EEC (CE marking)

#### UG

##### ULTRA GALVA (UG)

is a high-performant metallic coating which offers an optimum surface protection in a wide variety of aggressive and demanding environments, indoor as well as outdoor. The unique alloy of small amounts of magnesium and/or aluminium in the zinc bath provides ULTRA protection with a self-healing effect. Whilst zinc is essential for cathodic protection, magnesium prevents red rust. The passivation layer that comes on top, creates a seal that slows down the first traces of white rust.

ULTRA GALVA offers a number of advantages compared to the traditional hot dip finishing.

- the passivation layer offers a superior protection level. Hence, ULTRA GALVA, being cathodical, is self-healing in case of scratches, edges or perforations. Compared to hot dip, the articles remain very straight, no deflections appear nor flux or dull spots/ashes.
- ULTRA GALVA can conveniently be cold-processed without any risk on flakes because of the perfect adhesion of the coating to the metal.
- No zinc pins appear which enables one to install cables in a fast way avoiding any risk on damages to cables nor injuries of workers.
- Thanks to the longer life span, ULTRA GALVA does not require ongoing maintenance nor post painting actions.
- Three times less zinc is being applied compared to hot dip finishing. There is hence a lower impact on natural resources as well as less pollution. On top, its production process generates less CO2 emission and ULTRA GALVA is 100% recyclable.

ULTRA GALVA is hence a very valuable environmentally friendly alternative for the traditional stainless steel and hot-dip finishing !

#### EG

##### Electrolytically galvanized (EN ISO 2081) EG (electrogalvanized)

Electrolytically galvanized products are mostly used in places where limited chemical contamination is likely, for example, in offices, industrial buildings, covered parking lots, etc.

Electrogalvanizing differs from hot-dip galvanizing in that the zinc coating, in this case, is built up by electrolysis. With this technique, there are no thermal influences on the steel, so no layers of alloy will form. Also, the coating thicknesses of 6-8µm (micron) are more limited compared to hot-dip galvanizing.

Prior to the galvanizing, the steel sheet goes through several pre-treatment steps so as to ensure optimal adhesion (degreasing steps, pickling, a brief acid dip, multiple rinsing,....) After the galvanizing proper, the zinc coating receives a passivating- and dichromate coat, followed by a rinsing with demi-water. The advantages of electrogalvanizing are, among other things: no thermal deformation (so ideal for assembly parts), an attractive, uniform and perfectly smooth, high-gloss finish with good electrical conductivity, no runs in the paintwork or zinc jags.

#### DG

Hot-dip galvanized (EN ISO 1461) DG (dipped-galvanised)

Whenever cable support systems are exposed to the elements and/or caustic substances (such as petrochemical applications), they are given an additional treatment in the form of hot-dip galvanizing.

Hot-dip galvanizing is a materials science process designed to render the steel non-corroding. If this coating is breached, the zinc will act as a sacrificial anode, so that the iron is protected by the zinc (aka cathodic protection). During galvanization, three alloys are formed: an iron-zinc alloy, a zinc-iron alloy and also a zinc alloy. The pre-treatment of the steel is crucially important in order to achieve a good bond.

The following process steps are involved: degreasing, rinsing, pickling, re-rinsing, fluxing, drying and hot-dipping. The coating thickness depends on the steel composition, the material thickness and the time spent in the zinc bath. In the galvanizing standard NEN-EN-ISO 1461, the minimum coating thickness are prescribed (as shown in following overview), just as the zinc shrinkage per year which will depend on environmental factors (see table entitled 'Corrosion classes'). In addition, the zinc coating forms an excellent substrate for other post-treatments, such as applying a powder coating and coats of paint (better known as the duplex system).

An added advantage of hot-dip galvanizing is that along the edges and pointy bits, where objects are usually extra susceptible to corrosion, the zinc coating is thicker because of the behaviour of the liquid.

Minimum thicknesses of the zinc coating according to ISO 1461

- Using the hot-dip method

Material thickness  $\geq 6$  mm = min. zinc coating thickness (average) 85 $\mu$ m

Material thickness  $\geq 3$  mm to  $< 6$  mm = min. zinc coating thickness (average) 70 $\mu$ m

Material thickness  $\geq 1,5$  mm to  $< 3$  mm = min. zinc coating thickness (average) 55 $\mu$ m

Material thickness  $< 1,5$  mm = min. zinc coating thickness (average) 45 $\mu$ m

- Using the drum method

Material thickness  $\geq 3$  mm = min. zinc coating thickness (average) 55 $\mu$ m

Material thickness  $< 3$  mm = min. zinc coating thickness (average) 45 $\mu$ m

## CO

Polyester powder coating CO (coated)

Polyester coats will be used in moderate environments where the aesthetic aspect and sustainability must go hand in hand. The distinctive property of a polyester coating is its resistance to discoloration due to sunlight.

If used in a harsher environment, it is strongly recommended to apply an epoxy coating; this is less porous and therefore more resistant to chemicals. The disadvantage of an epoxy coating, however, is the rapid discoloration. If you want the best of both worlds, use an epoxy primer with a polyester top coat.

Just as with all the treatment techniques mentioned above, a thorough pre-treatment is crucial here too.

Depending on the base material, one will, in this case, degrease, rinse, pickle, rinse again, apply a conversion coat (e.g. chrome), rinse again, rinse with demi-water and/or dry.

Field of application according to resistance against corrosion:

**Corrosion classes according EN ISO 12994**

Corrosion class	Atmospheric corrosion	Indoor environment	Outdoor environment	Surface treatments
C1	<0,1µm	Heated buildings with neutral atmospheres: offices, shops, schools, hotels.		Electro-galvanised (EG) EN ISO 2081
C2	0,1 - 0,7µm	Unheated buildings where condensation may occur: sports halls, warehouses, shops.	Rural areas. Atmosphere with low impurities.	Pre-galvanised (PG) EN 10327 – EN 10143
C3	0,7 - 2µm	Production facilities with high moisture levels and some air impurities due to industrial processes: production plants.	City and industrial atmosphere, some impurities, coastal areas with low salt loads.	Dipped-galvanised (DG) EN ISO 1461
C4	2 - 4µm	Production facilities with high moisture levels and high air impurities due to industrial processes: swimming pools, Chemical industry.	Industrial areas and coastal areas with low salt load.	Dipped-galvanised (DG) EN ISO 1461 Polyester coating (CO) EN ISO 12944
C5-I	4 - 8µm	Polyester coating (CO)	Industrial areas with high moisture level and aggressive atmosphere.	Duplex (DU) (Dipped galvanised + Polyester coating) Stainless steel AISI 316L
C5-M	4 - 8µm	EN ISO 12944	Coastal or offshore areas with salt load.	Duplex (DU) (Dipped galvanised + Polyester coating)

**Classification for resistance against corrosion according to IEC61537**

Class	Reference- Material and Finish
0(a)	None
1	Electroplated to a minimum thickness of 5 µm
2	Electroplated to a minimum thickness of 12 µm
3	Pre-galvanised to grade 275 to EN 10327 and EN 10326
4	Pre-galvanised to grade 350 to EN 10327 and EN 10326
5	Post-galvanised to a zinc mean coating thickness (minimum) of 45 µm according to ISO 1461 for zinc thickness only
6	Post-galvanised to a zinc mean coating thickness (minimum) of 55 µm according to ISO 1461 for zinc thickness only
7	Post-galvanised to a zinc mean coating thickness (minimum) of 70 µm according to ISO 1461 for zinc thickness only
8	Post-galvanised to a zinc mean coating thickness (minimum) of 85 µm according to ISO 1461 for zinc thickness only (usually high silicon steel)
9A	Stainless steel manufactured to ASTM: A 240/A 240M – 95a designation S30400 or EN 10088 grade 1-4301 without a post-treatment (b)
9B	Stainless steel manufactured to ASTM: A 240/A 240M – 95a designation S31603 or EN 10088 grade 1-4404 without a post-treatment (b)
9C	Stainless steel manufactured to ASTM: A 240/A 240M – 95a designation S30400 or EN 10088 grade 1-4301 with a post-treatment (b)
9D	Stainless steel manufactured to ASTM: A 240/A 240M – 95a designation S31603 or EN 10088 grade 1-4404 with a post-treatment (b)
(a) For materials which have no declared corrosion resistance classification.	
(b) The post-treatment process is used to improve the protection against crevice crack corrosion and the contamination by other steels.	