

THE NEW SILENT+ MINI LIME QUIETLY BRILLIANT



**Silent+
Mini Lime**
FP3322/5
Rated 100-250V,
0.18A, 2.1W, 50/60Hz
Max. approx temp
40°/104° F IP24
Continuous, Alarm
contacts 230V/5A, Class II
CAUTION FOR PUMPING
WATER ONLY FOR INDOOR USE ONLY
ATTENTION POUR LE
POMPAGE DE L'EAU SEULEMENT
POUR UNE UTILISATION EN INTÉRIEUR
ASPEN CE UK CA



Simple & faster install.

No need for a damper, anti-siphon, buttons or lights.
No need for a Maxi Lime – this pump is a Mini and Maxi all-in-one.

Fits all trunking systems.

Plus, our Kwik Fix range is available in three colours (white, cream, black).

Plug & Play. Backwards compatible. Perfect for replacement installations.
Replacement pump available, alongside the complete system.

Near-silent operation. As low as 16dB(A)@1m.

Variable speed, on demand power, no-touching parts = silence.

Proven tech. Same tech as our best-selling Silent+ Mini White.
Only works when it needs to. Up to 10 x lower power consumption.

An impressive flow rate of up to 40 l/h, larger tank and head capability.

Satisfaction guaranteed. All backed with a three year guarantee.



* Kwik Fix, Slimline, BBJ are trademarks of Aspen Pumps.
† SpeediDuct® & Optimal® (registered trademarks of Castel Engineering).

Information correct at time of going to press. Not all products are available in all regions.



Silent+ Mini Lime®

CONDENSATE REMOVAL PUMP

The new and improved 5th gen Silent+ Mini Lime – just 16dB(A) this is the quietest and most versatile of elbow pumps. Simple and flexible to install. The proven technology delivers an impressive flow rate and lower power consumption. All round maximum performance, on-demand power, near-silent operation, optimum reliability and increased energy efficiency.

- 40L/h max. flow
- 15m max. rec. head
- 16 dB(A) @ 1 m

Key Features

- Backwards compatible Plug & Play cable
- Fits all popular trunking systems
- Quick install – no longer need for a damper, anti-siphon
- 40L/h flow rate and up to 10 x lower power consumption

Suitability

- Up to 46kW / 157,000Btu/h
- High wall split systems
- Left or right install with range of trunking systems
- **Perfect for...**
Commercial and domestic use where silence is important

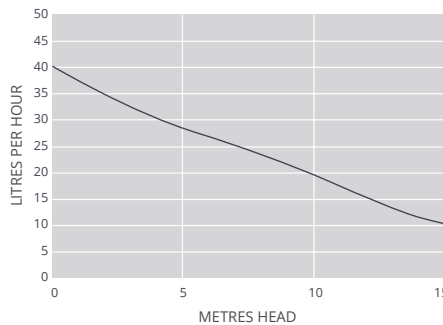
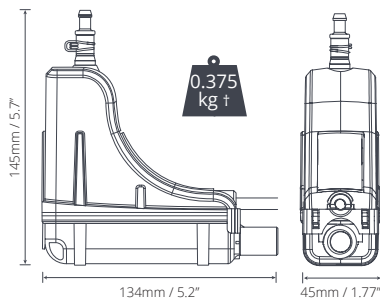

SUGGESTED XTRA ACCESSORIES

Description	Part No.
1 Amp Fuse	FP2620
Tube To Soil Stack Adaptor	FP2038
Vinyl Tube Braided 1/4" (6mm)	AX5100

Univolt 100-250 VAC 50-60Hz	
Max. flow	40L/h @ 0m head
Max. rec. head	15m
dB(A) @ 1m	As low as 16*
Power supply	100-250 VAC, 0.18A, 2.1W, 50/60Hz
Rated	Continuous
Class	II
Max. unit output	Up to 46kW / 157000Btu/h
Max. ambient temp	40°C
Inlet/Outlet connections	Inlet o/d: Ø16mm Outlet o/d: Ø6mm
IP Protection	IP24
Safety switch	5.0A N.C. (Normally Closed)
Self priming	✓

SYSTEM OPTIONS		
System	Colour	Part No.
Slimline	Ivory	FP3312/5
	White	FP3319/5
Kwik Fix	Cream	FP3323/5
	Black	FP3325/5
	White	FP3324/5
O-Ducting	White	FP3327/5 ‡
S-Ducting	White	FP3320/5 ‡
Inoac	White	FP3321/5
Silent+ Mini Lime Replacement†		FP3322/5

IN THE BOX
Silent+ Mini Lime pump (including 1.5m Plug & Play cable) • 500mm Lime green inlet hose 14mm ID • 40mm Vinyl breather tube 6mm ID • Elbow front and back • 800mm trunking front and back • Internal trunking sleeve (Slimline system only) • Gasket (Slimline, S-Ducting and Inoac systems only) • Ceiling plate • Drain connector kit • Fixing kit • Quick Start Guide

- Visit aspenspumps.com for more installation accessories.
- Download manual at aspenspumps.com
- Watch installation video at aspenspumps.com

*Assuming solid wall construction with a 2kW unit.

‡ FP3320/5 trunking system is SpeediDuct® compatible.
 ‡‡ FP3327/5 trunking system is Optimal® compatible.
 (SpeediDuct® & Optimal Duct are registered trademarks of Castel Engineering).

Information correct at time of going to press. Not all products are available in all regions.