

THE EPICENTER[®] Plus

Bass Restoration Processor Owner's Enjoyment Manual

Greetings from the rainforest dwellers of the Pacific Northwest. We would like to congratulate you on your purchase of The Epicenter Plus from AudioControl. As the name suggests this processor is based on AudioControl's legendary (and patented) bass restoration circuitry, appropriately named The Epicenter. Whether this is your first AudioControl product, or you are already a firm believer, the bass restoration enhancements of The Epicenter Plus will leave you breathless. Extra octaves of deep, body shivering bass can dramatically increase the enjoyment of your performance autosound system.

The Epicenter Plus is for audio enthusiasts who want to use their factory-installed source units so it is equipped with AudioControl's high-impedance, speaker-level inputs. Additionally, an auxiliary input allows users of factory-installed radios and portable audio players (like iPods™) to also appreciate the performance of its bass restoration circuitry.

We are sure that by now the thought of adding The Epicenter Plus to your performance autosound system is probably making you salivate. However, we strongly encourage you to take a few minutes to sit back, grab a beverage of your choice and read through this manual. Although many autosound enthusiasts feel reading an "owner's manual" is only for novices, this particular manual may save you some phone calls during the installation process. It also contains lots of useful facts and information (and besides, we spent a lot of time writing it)!!

Key Features Of The Epicenter Plus

Here are a few key features that you will find in The Epicenter Plus:

- Patented Bass Restoration Circuitry
- Speaker-Level Inputs for Integration with Factory Audio Systems
- Auxiliary Input for iPod's, MP3 players or Satellite radio tuners
- GTO™ Signal Sensing Inputs for Automatic Turn-on
- Bass Maximization Circuitry
- 12 volt trigger output
- Dash mount control
- PFM Subsonic Filter
- Balanced Pre-amp inputs

What all this means is more bass and better bass from your performance audio system. Enjoy the ride...

AudioControl[®]

22410 70th Avenue West • Mountlake Terrace, WA 98043 USA
Phone 425-775-8461 • Fax 425-778-3166 • www.audiocontrol.com

Features and Highlights

Patented Bass Restoration Circuitry

The Epicenter Plus contains AudioControl's patented (#4,698,842) bass restoration circuit that recreates and injects low frequency information back into the signal path. What that means in everyday terms is that The Epicenter Plus will give dramatically more bass impact in your music regardless of whether your choice of format is compact discs, MP3, AAC, WAV, AIFF, AU, FKAC, TTA, WMA or good ol' tapes. For more on this unique process, see page 8.

Auxiliary Input

Since many car audio enthusiasts are multi-tasking listeners who want to use secondary sources like iPods, MP3 players, and satellite radios, The Epicenter Plus provides an auxiliary audio input for these devices. If you use this function, you will need to use a source that has its own volume control. The Auxiliary input is easily activated by tapping the dash control knob. You will be happy to know that The Epicenter Plus has a cool blue LED indicator that will light when the Auxiliary input is activated.

Speaker-Level Inputs

If you are like many people who enjoy the look and features of your factory-installed source unit but feel your system is lacking in power and bass, we have good news. The Epicenter Plus has high-impedance speaker-level inputs that allow it to accept amplified signals from all known factory-installed systems (even Bose) and output a high-quality pre-amp signal via standard RCA connectors. This will allow you to add better-quality aftermarket amplifiers, processors and speakers while keeping the convenience features of your factory-installed source unit. Unlike inexpensive speaker-level and line-output converters, The Epicenter Plus offers the highest sound quality and can handle the full signal strength of a 400-watt per channel amplifier.

GTO™ Signal-Sensing Inputs

Most factory-installed source units lack the features that make it easy to upgrade with really good-sounding, performance aftermarket products. One of those key features is a 12-volt trigger that will "turn-on" devices like The Epicenter Plus and your external amplifiers. Therefore, we have equipped the speaker level inputs of The Epicenter Plus with our unique GTO™ (Great Turn On) signal-sensing inputs. Once the GTO inputs of The Epicenter Plus detects a signal, it powers up. When the signal goes away, The Epicenter Plus will automatically turn off. Optionally, The Epicenter Plus is also equipped with a standard 12-volt trigger (Remote In) that will allow you to turn on The Epicenter Plus in the traditional manner when you are using the pre-amp inputs.



12-Volt Output Trigger

Since you will be using an external amplifier(s) and processor in your system, you will need the ability to “trigger” or turn-on these devices (a romantic dinner won’t quite work here). The Epicenter Plus has a high-current 12-volt output (labeled “Remote Out”) that will provide a trigger to these remote devices, when The Epicenter Plus is powered up. Please note that this output is not to be used as the main power for these devices.

Dash Mount Control For Source Selection and Bass Restoration

The Epicenter Plus is designed to be mounted anywhere in the vehicle, with the exception of the radiator or front bumper. It comes with a dash-mountable control that allows you to enjoy the bass-restoration effects of The Epicenter Plus without having to leave the driver’s seat. Additionally, by just tapping the switch, you can select between the main inputs (Pre-amp/speaker level) and the auxiliary input. The LED turns cool blue when the auxiliary input is engaged.

PFM Subsonic Filter

This unique feature is legendary with many AudioControl fanatics for its ability to fine tune the bass response of any system. Why waste power on nasty subsonic information when your Programmable Frequency Match (PFM) filter can help you clean things up?

Bass Maximization Circuitry

The Epicenter Plus circuitry has the ability to produce large amounts of deep, mind shattering bass without damaging your speakers. The Bass Maximization circuit allows The Epicenter Plus to maximize the bass output of any autosound audio system while restraining destructive bursts. If your are a speaker, this is a good thing.

Five Year Warranty

The most important feature of all. Every AudioControl product is selflessly designed and manufactured by the occupants of our rainforest factory. We take every effort to ensure that you will have many years of enjoyment out of The Epicenter Plus. To further ensure the performance of your new toy, we highly recommend that you allow your authorized AudioControl dealer to perform the installation. Not only do they have all the right knowledge and tools, but in the unlikely chance The Epicenter Plus should fail, we back it with a limited five year parts and labor warranty. Should you choose to install it yourself, we will still give you a one year parts and labor warranty. To activate your warranty, you need to FILL OUT AND SEND IN YOUR WARRANTY CARD!



We also recommend that you save your invoice or sales slip as proof of installation and ownership. Not only is it necessary for warranty purposes, but should The Epicenter Plus turn up missing some day while you are out watching submarine races, you will find insurance companies very unforgiving.

Quick Install Information

Integration With A Factory Installed Audio System

We interrupt your reading of this manual to provide the impatient people with “Quick Install” information and guidelines. No matter how much more of this manual you read, definitely look at the system drawings on page 10. Not only will they help with system design, but if you look at them backwards you may find a hidden message (NOT!).

As you have probably figured out by now, The Epicenter Plus needs to be installed in the signal path between a source and an external amplifier(s). If your factory installed audio system has an amplifier, then use the speaker wires after the factory amplifier to feed a signal into The Epicenter Plus.

The Epicenter Plus also works the best when it receives a full range signal. If you feel your bass response is somewhat lackluster, then the frequency response of the signal you are feeding The Epicenter Plus may be too low. Try finding a full range signal or use an AudioControl LC6i to sum the signals together.

Once this is done, you just need to hook up power, ground, trigger, run the wire to the dash remote and tada!!! Instant bass. If you need to know more, then read on. Heck if you don’t think you need to know more, you should still read on, because you can never know too much.

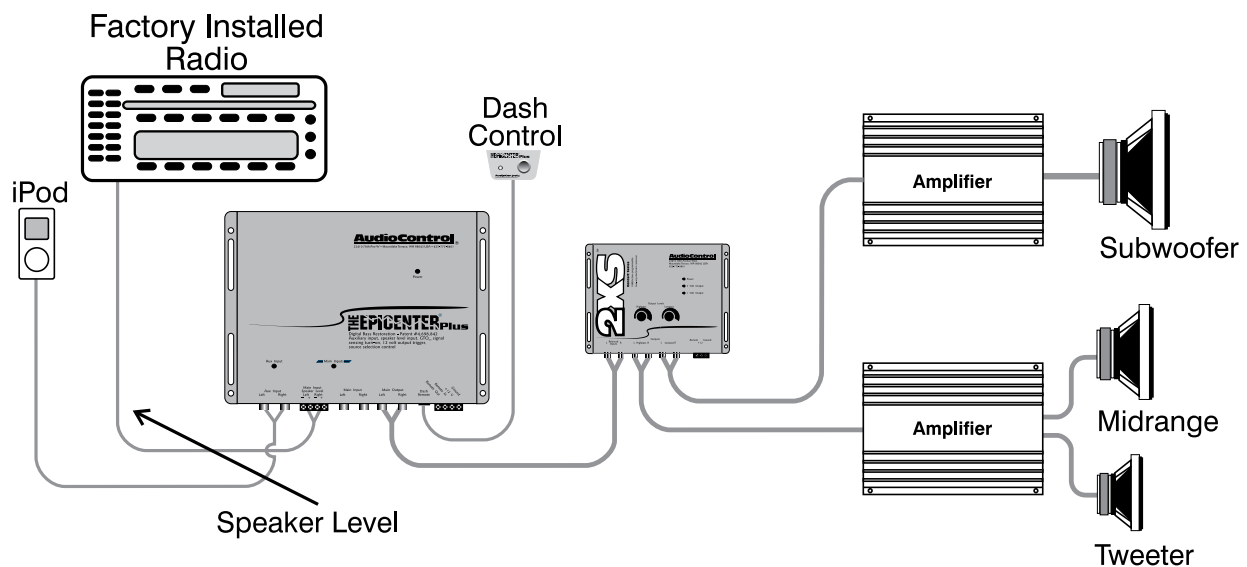

Figure 1: Basic Installation Of The Epicenter Plus

We now return you to your normal owner’s manual...

A GUIDED TOUR OF The Epicenter Plus

The Outside

1. Auxiliary Input: This RCA connection can accept any two-channel audio signal that comes from secondary source devices like an iPod, MP3 player, or Satellite radio. To activate this input, you need to tap the dash control and The Epicenter Plus will switch between the main inputs and this auxiliary input. The LED indicator above the “Aux Input” will identify when this input is being used.

2. Speaker-level Inputs: If you would like to use The Epicenter Plus with a factory-installed source you will be happy to know that it is equipped with AudioControl’s high impedance speaker-level inputs. These inputs should get their signals from the full-range speaker-level outputs of your factory-installed source unit or amplifier. If your source unit has front, rear, and subwoofer speaker-level outputs, then you may need to use an AudioControl LC6i, LC7 or LC8 to sum these signals together.

3. Audio Pre-Amp Inputs: The pre-amp inputs of The Epicenter Plus use a balanced input circuit to help minimize induced noise. They are also designed to handle very high signal voltages up to 15 volts!! When these inputs are activated, the “Main Inputs” LED will be Red. When using these inputs you will want to provide The Epicenter Plus with a full range signal.

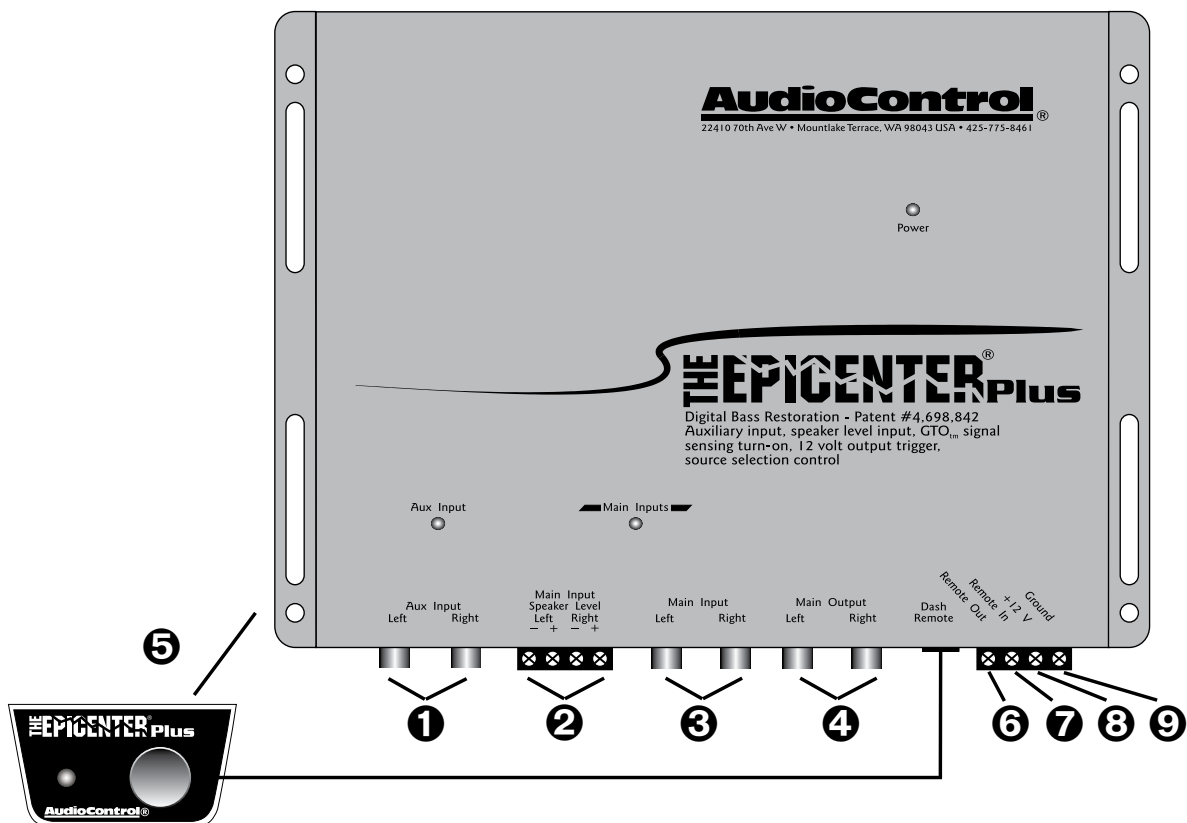

Figure 2: The Epicenter Plus top cover

4. Pre-Amp Outputs: These RCA connectors should be connected to the next component after The Epicenter Plus, such as a crossover, equalizer, or amplifier.

5. Restoration Level Control/Source Selector: This knob allows you to increase or decrease the bass restoration of The Epicenter Plus. Additionally, tapping the knob will toggle between sources. You can mount the knob anywhere you want, although somewhere in the front of the vehicle is preferable.

6. Remote Out: Outputs 12 volts when the The Epicenter Plus is powered up so you can turn on external devices like signal processors and external amplifiers or relays if necessary. Do not use for system power!!

7. Remote In: Allows The Epicenter Plus to be turned on remotely with a 12-volt signal.

8. +12 Volt: Connect to a good source of power (the battery comes to mind).

9. Ground: Connect to a good, verified chassis ground (once again, the battery comes to mind.) Warning: Factory ground wires typically already have multiple devices connected to them and are not recommended.

The Inside

RCA Input Grounding: Depending upon the wiring topology of your audio system, some components may look for an “audio” ground through the RCA connectors or speaker wires. In this case your system may encounter engine noise whine. For most systems you can leave this jumper set in the UNBALANCED position. In the event you need additional noise rejection you can change the jumpers to the BALANCED position.

Ground Isolation Jumpers: Occasionally alternator whine may appear in a system because the source unit and amplifier use different grounding. To help in this situation, we have provided alternative grounding connections. Make sure your system is turned OFF before you move these jumpers.

Bass Maximization Circuit: Not all systems are designed the same. Some systems are designed strictly for SPL (sound pressure level) while others are a little more passive. The Bass Maximization circuit can either increase or decrease the mix signal voltage of the bass restoration circuit. Depending upon your system, you may opt to change these jumpers to a higher or lower setting to maximize your bass output and protect your speakers. In most systems the factory setting will suit you fine. We recommend you try the factory setting first.

PFM Subsonic Filter: The Epicenter Plus utilizes a PFM (Programmable Frequency Match) filter which will help with speaker control and amplifier power management. To change the PFM frequency, you need to remove the top of the chassis and change the modules. Your local AudioControl dealer generally carries an assortment of these replacement modules. This is discussed in detail on page 10. Once again, we recommend you try the factory setting first.

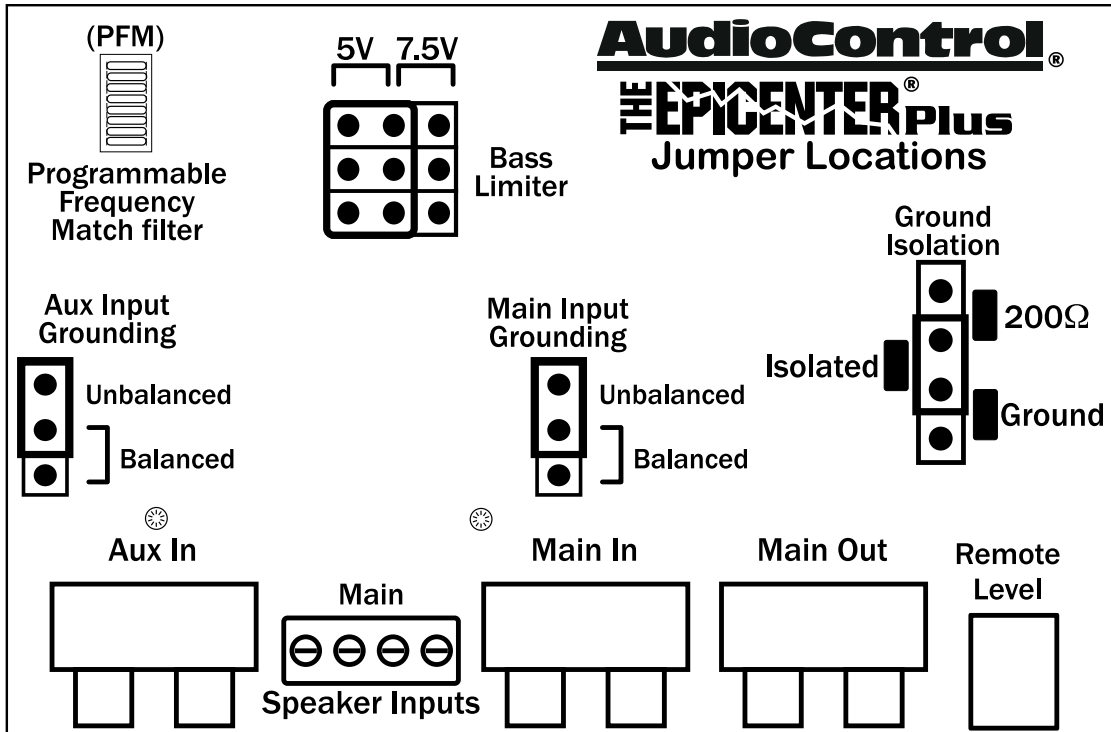

Figure 3: Inside view of The Epicenter Plus

Factory Setting	Shipped	Options
Bass Maximization Voltage	5 volts	5 or 7.5 volts
Input Circuit	Unbalanced	Balanced
Ground Isolation	Isolated	200 ohm or Ground
PFM Subsonic Filter	33Hz	20Hz, 25Hz, 30Hz, 35Hz, 40Hz, 45Hz <i>Optional PFM modules are sold separately.</i>
Choice of beverage	Micro-brew	Latté

Note: These configurations can be changed by moving jumpers, or changing modules.

The Magic Of The Epicenter Bass Restoration Technology

You may ask yourself, “Why would I need to restore bass? Where did it go? Who took it and more importantly, “How do I get it back?”. The truth is that when music is recorded in a studio, low frequency information can be “mixed” down or filtered out. It’s not that recording engineers are out to get you; in fact they are looking out for your best interests and are concerned that many speaker systems cannot handle “truly” low bass information.

Portable Audio Owners Rejoice!

If you use a portable audio player like an iPod or other MP3 player then you will really love the Bass Restoration characteristics of The Epicenter Plus. When you download songs and rip or “compress” them, you may notice that your bass sounds rather thin, even on tiny ear buds. That’s because when you are removing “bits” and ripping songs into smaller files, the bass response ends up suffering.

The unique bass restoration circuit inside The Epicenter Plus looks at the low frequency harmonics that are in upper frequencies and uses them to recreate the lower bass notes that have been rolled off or removed. We could tell you more but what really matters is that The Epicenter Plus technology gives you deep, body shuddering, heart-stopping bass.

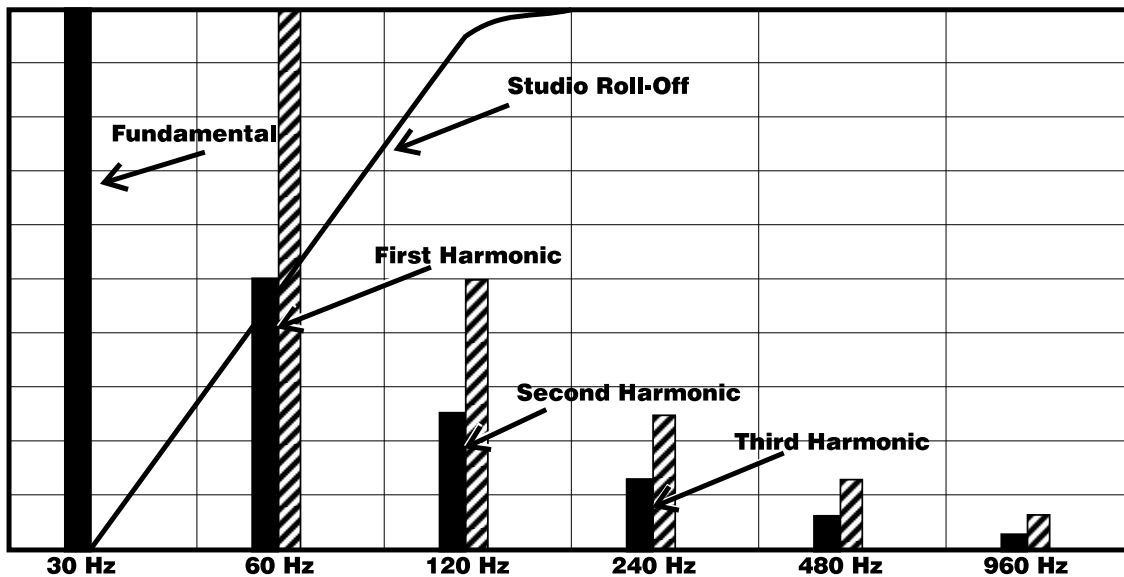

Figure 4: Bass Restoration Process

Installing The Epicenter Plus

Up to this point everything you have read has served to educate you on the operations of The Epicenter Plus. We are sure that you are chomping at the bit to install The Epicenter Plus so we recommend you read the following sections very carefully.

Placement & Mounting of The Epicenter Plus

The Epicenter Plus can be physically installed in numerous locations like behind your dashboard, under a seat, or even in the trunk. Since you will be connecting to pre-amp outputs or speaker wires from the source unit or its amplifier(s), you should select a location that is convenient for wiring. Once you have selected a permanent mounting location, position the unit and mark the appropriate mounting holes with a felt-tip pin or scratch awl. Before doing anything else, make sure you are not about to drill a hole in a gas tank or pierce any existing wiring. Nothing ruins your day more than an expensive repair bill. Drill a few small pilot holes and secure the chassis of the The Epicenter Plus with self-tapping screws. If it is possible, for maximum ground isolation you should try and avoid mounting The Epicenter Plus to metal.

The Epicenter Plus Power Wiring

WARNING: *Failure to disconnect the negative terminal of your battery prior to the installation of The Epicenter Plus can result in a warm tingly feeling.*

(+12V) Positive Connection: Insert a 12 to 18 gauge wire into the connector labeled “+12” on the nifty connector of The Epicenter Plus. Connect it to a good constant source of 12 volts (we suggest the battery), fused at 2 amps.

Ground Connection: Use the same gauge wire or larger as you did for the positive connector and run it from the “Ground” connector on your The Epicenter Plus to the negative terminal of the battery, a ground bus, or a verified ground location. The factory head unit ground is not a good ground!

Remote In: As we previously mentioned, The Epicenter Plus is equipped with AudioControl GTO™ signal sensing which allows it to turn on when it detects a signal at the Main speaker-level inputs so you may not need to use the “Remote In” feature. If you do, connect a 22 to 18 gauge wire from the source unit’s remote turn-on or other trigger to the Remote connector on The Epicenter Plus.

Remote Out: If you are going to use the The Epicenter Plus to turn on any external signal processors or amplifiers, connect an 18 to 22 gauge wire from the Remote Out on the The Epicenter Plus to the remote turn-on of the processors or amplifiers. Depending upon how many other components you are turning on, you may need to connect this wire to a relay and route 12 volts from another source.

Once the electrical connections are complete, you will want to reconnect the negative terminal to your battery, however continue to act positively.

The Epicenter Plus Audio Wiring

The Epicenter Plus should be installed in the signal path after your factory source unit or amplifier but definitely before your aftermarket amplifiers and/or any signal processors. You may already have guessed there are numerous ways to configure The Epicenter Plus in your audio system so we recommend you spend a little quality time planning out your system and even sketching it out on paper. There are some examples on the next pages.

System Diagrams

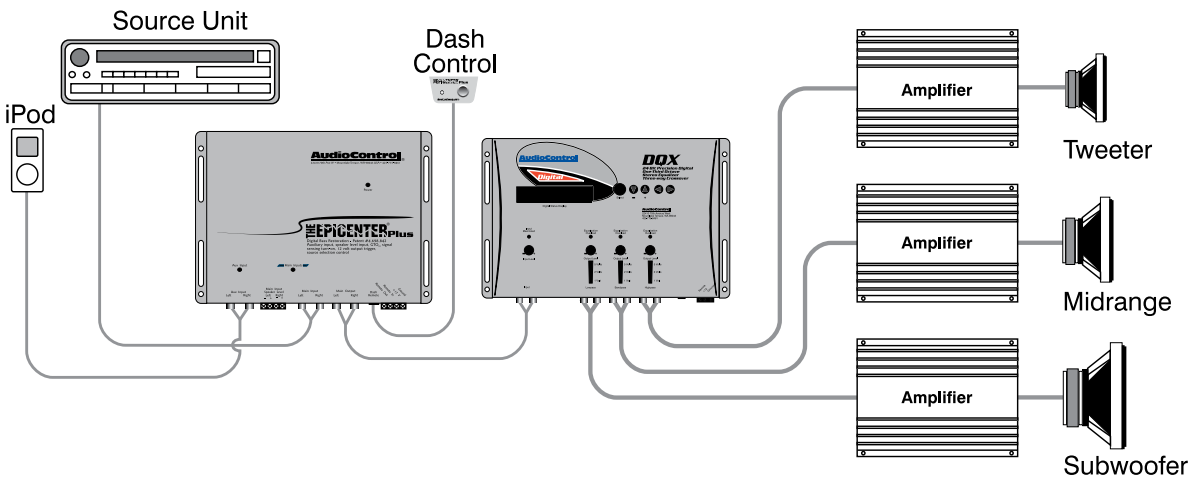

Figure 5: Two channel system with equalizer and crossover

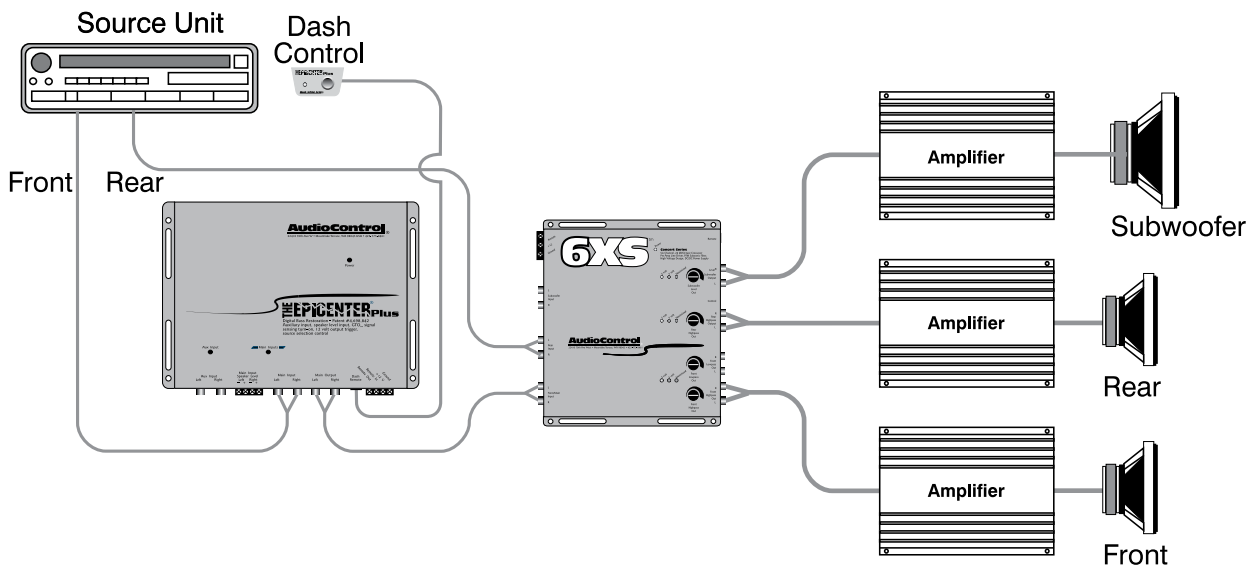

Figure 6: Four channel system with crossover

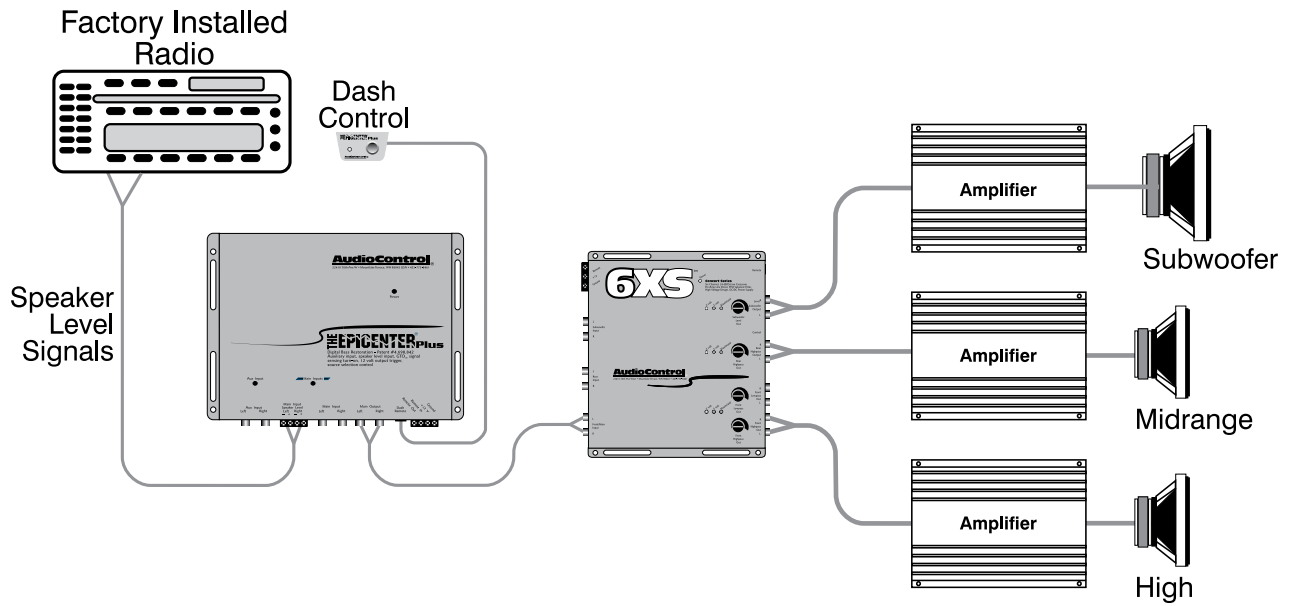

Figure 7: Interfacing with a factory installed radio plus a 6XS crossover

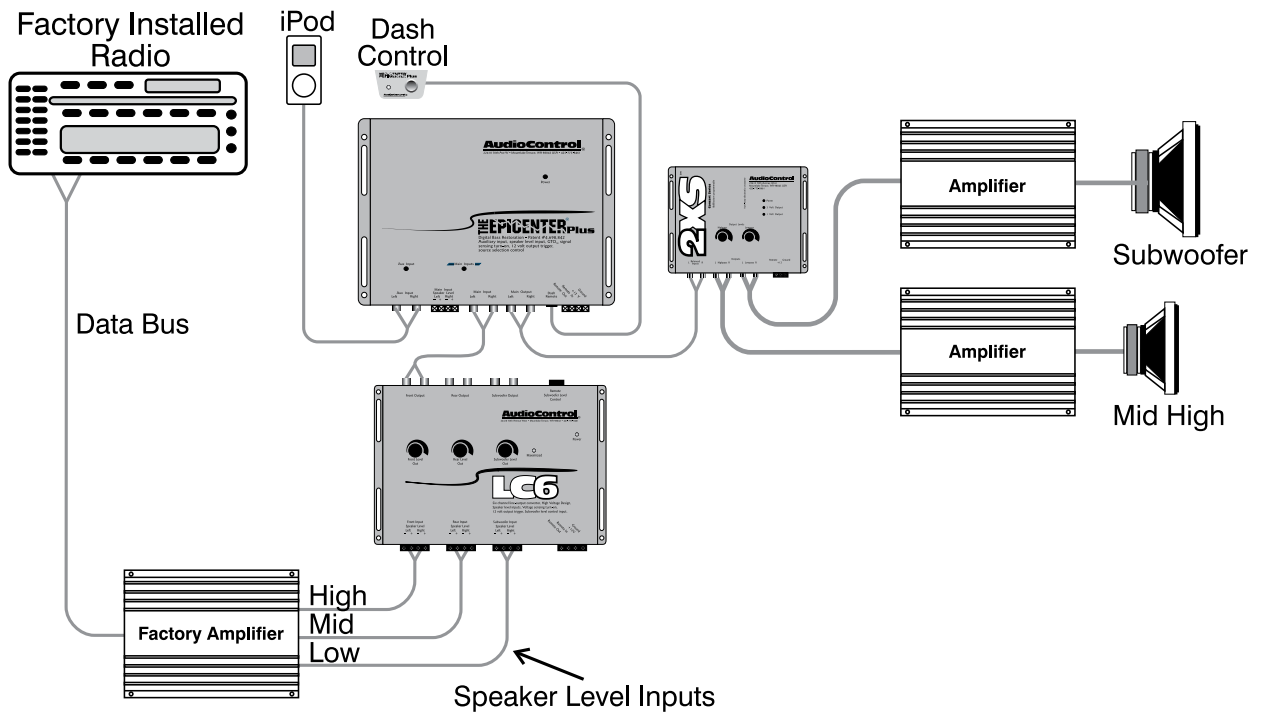

Figure 8: Interfacing with a factory installed radio/amplifier using an AudioControl L6i for signal summing

Using The Speaker-Level Inputs

The Epicenter Plus is designed to accept an amplified, speaker-level signal from a factory source unit or amplifier. You will want to refer to a factory service manual or wiring-harness schematic to determine which wires are the speaker wires for your system. If you are unsure which wires are the speaker wires, it is recommended you look at the color of the speaker wire connected to the speakers and follow them back to the factory source or amplifier. Connect the speaker wires to the Speaker-Level Inputs on The Epicenter Plus. Make sure to get your “pluses” and “minuses” connected properly.

Auxiliary Input

Many car audio enthusiasts have a number of sources of music above and beyond their factory-installed source unit. Believe it or not, downloading music from the Internet onto an iPod or an MP3 player is getting more and more popular. By last count there were only 100,000,000 plus users! To help users interface with any secondary stereo source, The Epicenter Plus is equipped with an auxiliary two-channel input. To activate this input, you simply need to tap the dash control knob and The Epicenter Plus will switch between the main inputs and this auxiliary input. The bright LED indicators on The Epicenter Plus will identify which source unit is being used. Additionally the light on your dash control will turn bright blue when the auxiliary source is selected. You will still need to use the volume control on your source unit when you switch between your iPod and the main radio inputs, so the volume level won't blow your ears off.

Dash Control For Source Selection & Restoration Level

Placement And Mounting

The dash control may be mounted under the dash using its own bracket or through a custom hole in the dash. It should be within reach of the driver and in a spot where the LED is plainly visible.

Dash Bracket Installation

The dash control mounts with two screws, which attach to the underside of the dashboard. Slide under the dash and place the dash control in its mounting position. Mark the two mounting holes, drill pilot holes, and secure with two screws.

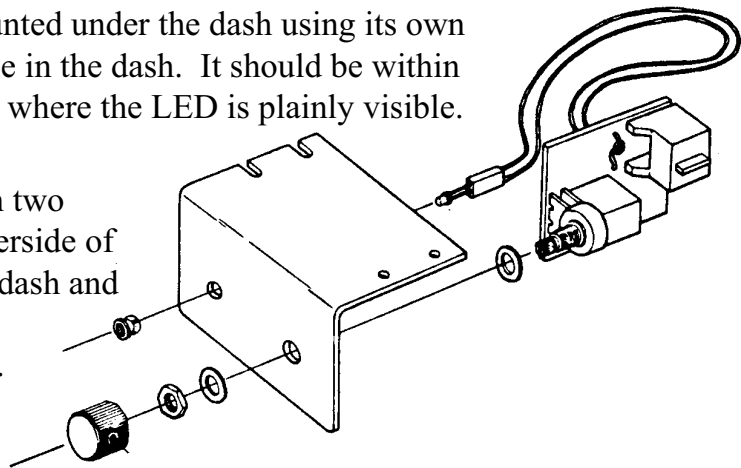

Figure 8: Dash Control Assembly

Custom Installation

For that custom, finished look, the dash control can be flush mounted directly on the dashboard (or anywhere else). We have provided an extra label to help make this happen. Referencing Figure 8, disassemble the dash control from the mounting bracket. Start by pushing the LED from its holder followed by removing the circuit board and rotary control from the bracket. Drill a 9/32 hole in the dashboard for the control along with a 1/8 hole for the lock tab and a 13/64 hole

for the LED holder. Reassemble the dash control components on the dashboard and apply the new label over the openings.

Setting The Bass Maximization Control

The Epicenter Plus is the most powerful bass processor in the history of autosound. Able to leap tall buildings with a single bound and all that kind of stuff. With that in mind we have equipped The Epicenter Plus with two different Bass Maximization selections. If you should need to change the settings, please use the chart below for guidance. A word of advice: listen to the factory setting before changing your Bass Maximization settings.

Recommended Settings

Setting	Amplifier Input Voltage	Minimum Speaker Size
5 Volt	5 volts or less	10"
7.5 Volt	7.5 volts or less	12"

PFM Subsonic Filter

Many car audio systems truly push the limits of their subwoofer...without really knowing it. Tuned enclosures affect the roll-off of many speakers, yet lots of source material forces the speakers to play lower than expected. The net result is wasted amplifier power and damaged speakers. The AudioControl PFM (Programmable Frequency Match or Pure F#@&% Magic) filter is a programmable subsonic filter. It allows you to let the speaker play only as low as it should be playing. Because every system is different, we allow you to change the PFM roll-off frequency to whatever you choose.

On most systems, the factory installed module (33Hz) is fine. If you know the tuning frequency of your speaker enclosure (porting frequency or 3dB down point), you might try setting your PFM module to that frequency. If you want to protect your speaker system even more, you might even try a higher frequency. Often a higher frequency actually sounds louder and cleaner.

TROUBLESHOOTING

No Power

Check the "Power" light on the chassis of The Epicenter Plus. If the "Power" light is on, you will want to check to make sure that the cable connecting the dash remote to the chassis is not pinched or disconnected. If the "Power" light is off, check to make sure that the power wire and remote turn on wires are connected or a fuse has not blown.

No Bass Restoration

When your system is playing and yet you don't hear any difference in the sound, try turning the knob clockwise. If you still don't hear any affect, then you need to make sure that you have The Epicenter Plus in the right part of the signal chain. It must be installed BEFORE any crossovers in the system for best, thundering performance.

Note: If you are using a source unit with a built in crossover or processor, you must run a full range output to The Epicenter Plus' inputs. If you are not using the GTO™ circuit, make sure you have the 12 volt trigger connected.

No Sound

Check the source selection LED's on The Epicenter Plus chassis and/or the dash control. If you have the auxiliary input selected but you are not using and a secondary source you will get no sound. Tap the dash control to change inputs.

Sounds Distorted

Should your system sound distorted or your speakers are moving way too much, you should decrease the amount of bass restoration by turning the dash control knob counter-clockwise. You should also raise the PFM frequency or lower the setting on your Bass Maximization control.

Still Distorted

If you still have distortion, you should power down The Epicenter Plus, remove the cover and change the Bass Maximization setting to a lower position (i.e. 5 volts).

IF YOU LIKE The Epicenter Plus, YOU'LL LOVE . . .

The DQX six-channel equalizer/crossover, is the perfect trunk mount digital processor for those of you who want to improve the sound and detail of your vehicle. Less than ideal factory speaker locations can make even the best speaker systems cry out for help. The equalization controls on the DQX provide you with an ideal amount of tone control to tame even the most challenging acoustical situations.



The DQX offers 30 bands of precise equalization control for each channel plus a 3-way crossover with breath takingly steep 24dB-per-octave slopes. If performance is important to you, then you will appreciate the DQX. In addition, our optional DDC Digital Dash Control allows you to control all of the functions of your AudioControl digital processor from the convenience of your driver's seat including accessing the eight non-volatile memories.



And now a word from our legal department....

THE WARRANTY

People are scared of warranties. Lots of fine print, months of waiting around. Well fear no more, this warranty is designed to make you rave about us to your friends. It's a warranty that looks out for you and helps you resist the temptation to have your friend, "...who's good with electronics", try to repair your AudioControl product. So go ahead, read this warranty, then take a few days to enjoy The Epicenter Plus before sending in the warranty card and comments.

"Conditional" doesn't mean anything ominous. The Federal Trade Commission tells all manufacturers to use the term to indicate that certain conditions have to be met before they'll honor the warranty. If you meet all of the conditions, we will warrant all materials and workmanship on The Epicenter Plus for one year from the date you bought it (five years if it is installed by an authorized United States AudioControl dealer). We will fix or replace it, at our option, during that time.

Here are the conditional conditions:

1. You have to fill out the warranty card and send it to us within 15 days after purchasing The Epicenter Plus.

2. You must keep your sales receipt for proof of purchase showing when and from whom the unit was bought. We're not the only ones who require this, so it's a good habit to be in with any major purchase.

3. The Epicenter Plus must have originally been purchased from an authorized AudioControl dealer. You do not have to be the original owner, but you do need a copy of the original sales slip.

4. You cannot let anybody who isn't: (A) the AudioControl factory; (B) somebody authorized in writing by AudioControl to service The Epicenter Plus. If anyone other than (A) or (B) messes with The Epicenter Plus, that voids your warranty.

5. The warranty is also void if the serial number is altered or removed, or if The Epicenter Plus has been used improperly. Now that sounds like a big loophole, but here is all we mean by it.

Unwarranted abuse is: (A) physical damage (don't use The Epicenter Plus for a car jack stand); (B) improper connections (120 volts into the power jack can fry the poor thing); (C) sadistic things. This is the best mobile product we know how to build, but if you mount it to the front bumper of your car, something will go wrong.

6. If an authorized United States AudioControl dealer installs The Epicenter Plus, the warranty is five years otherwise the warranty is one year.

Assuming you conform to 1 through 6, and it really isn't all that hard to do, we get the option of fixing your old unit or replacing it with a new one.

LEGALESE SECTION

This is the only warranty given by AudioControl. This warranty gives you specific legal rights that vary from state to state. Promises of how well The Epicenter Plus will perform are not implied by this warranty. Other than what we have covered in this warranty, we have no obligation, express or implied. Also, we will not be obligated for direct or indirect consequential damage to your system caused by hooking up The Epicenter Plus.

Failure to send in a properly completed warranty card negates any service claims.

THE EPICENTER[®] Plus

Specifications

All specifications are measured at 14.4 VDC (standard automotive voltage). As technology advances, AudioControl reserves the right to continuously change our specifications, like our weather.

Maximum pre-amp input level.....	9.5 Vrms
Maximum speaker-level input	400 watts @ 4ohm
Maximum output level.....	9.5 Vrms
Frequency response.....	10Hz-22kHz; +/-1dB
Total harmonic distortion.....	0.003%
Signal to Noise ratio.....	- 130dB
Balanced input noise rejection	> 60dB
Input Impedance.....	20 Kohms
Output Impedance.....	150 Ohms
Power supply.....	High headroom PWM
Power draw	285mA
Recommended fuse rating.....	2 Amps
Maximum remote trigger output current.....	1 Amp
Size.....	8" W x 6.25" D x 1.15" H
Weight	3.5 lbs
Country of origin.....	U.S.A.

©2008, AudioControl, a division of Electronic Engineering and Manufacturing, Inc. All rights reserved.

AudioControl, The Epicenter, The Epicenter Plus, Making Good Sound Better, 6XS, DQT, DQX, DQS, DQXS, DDC, and EQL are all trademarks of Electronic Engineering and Manufacturing, Inc. iPod is a registered trademark of Apple Inc.

This literature was conceived, designed, and written on a bleak, windy, dreary rain-drenched day at our home in the Pacific Northwest Rainforest. The wheat beer was cold and so was the weather. No endangered species were harmed during the writing of this manual. Hybrid cars are parked in our lot.

AudioControl[®]
making good sound better[®]
22410 70th Avenue West
Mountlake Terrace, WA 98043 USA
Phone 425-775-8461 • Fax 425-778-3166
www.audiocontrol.com