

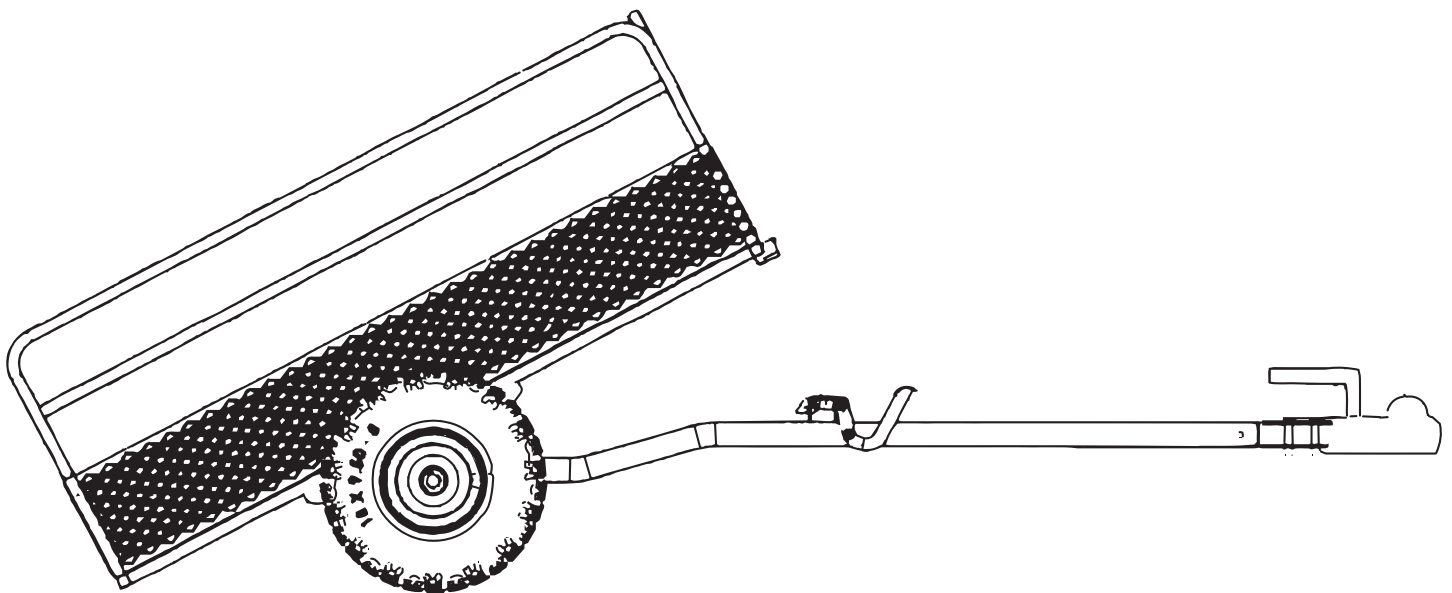

**SHARK ATV TRAILER
GARDEN 400**

**ASSEMBLY INSTRUCTION
FOR TRAILER**



STEP 1

Install one bracket **D** to trailer box **A** as shown, using hardware **1 2 3 4**.

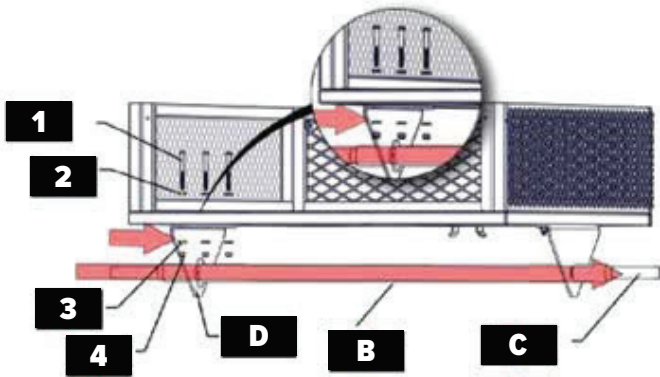
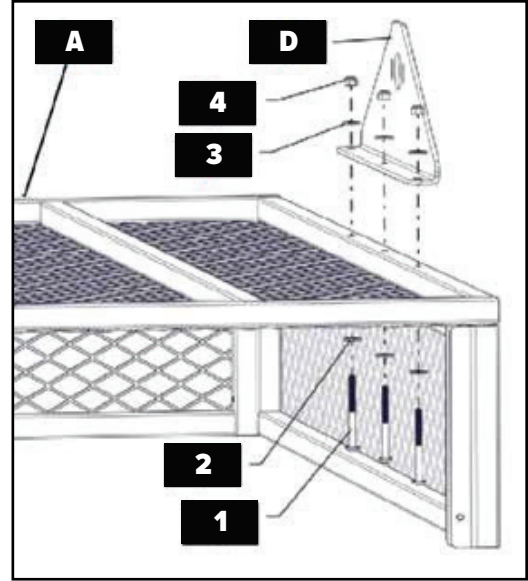

STEP 2

Install the other bracket **D** to trailer box **A**, like step 1. Then slide the axle tube **B** through the holes on both brackets **D**. Put the solid axle **C** through its axle tube **B**.

STEP 3

Attach the tongue **E** onto the axle assembly, using U connector **F**, fixing them with hardware **5 6 7 8**.

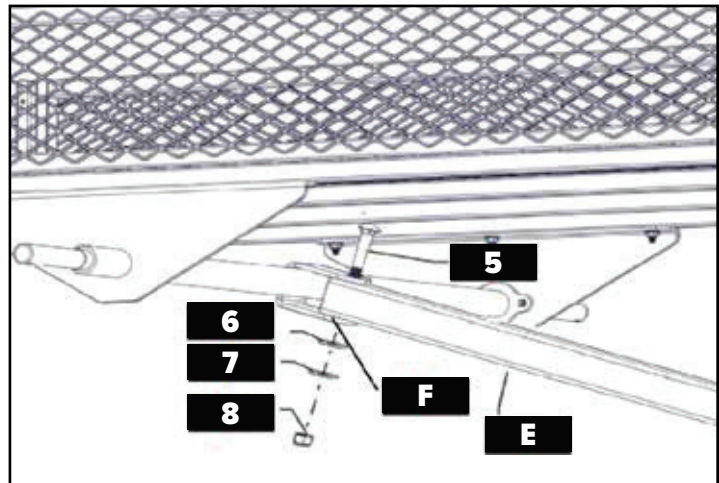

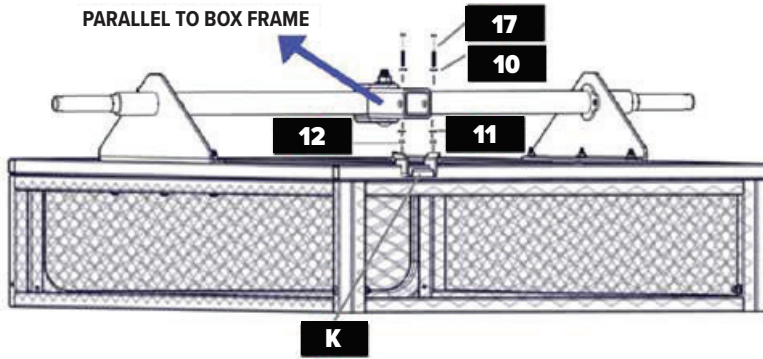

STEP 4

Install the front connector **K** onto the trailer box **A**, using hardware **10 11 12 17**.

STEP 5

Insert extension side rails **H**, front rail **G** and tighten them in places, as shown, using hardware **9 10 11 12**.

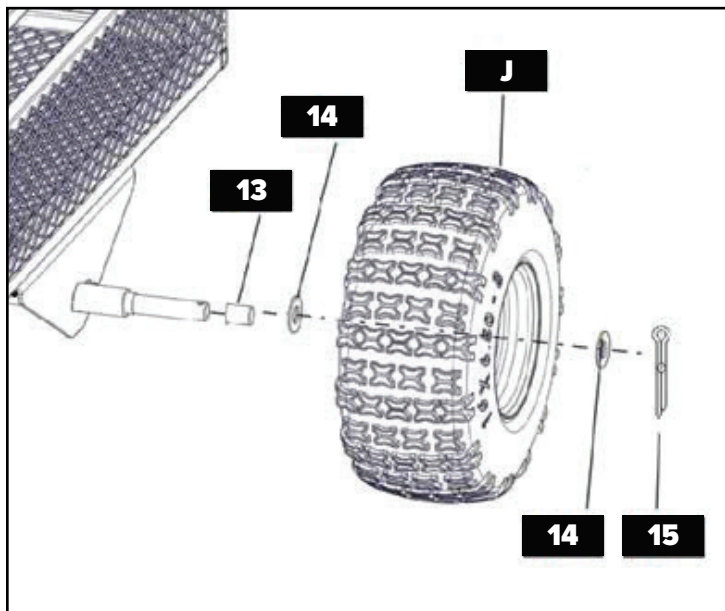
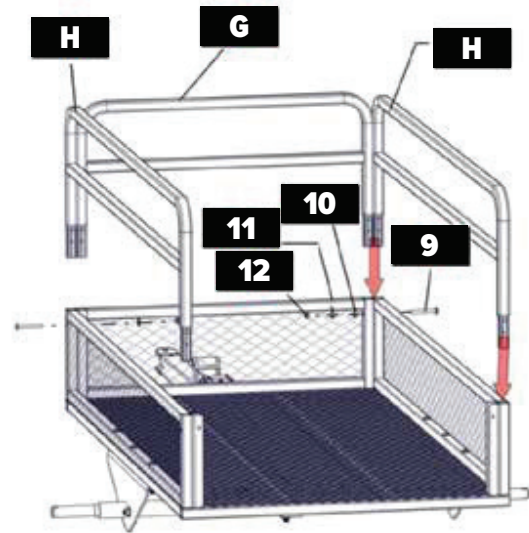

STEP 6

Slide the sleeve tube **13** onto axle, and then attach wheel **J** to the axle, as shown, using washer **14** on both sides. Cotter pin **15** must be locked in position as shown before moving the trailer.

STEP 7

Slide the tail gate **I** between bracket on trailer box **A**, then fix the two ends with hardware **16**.

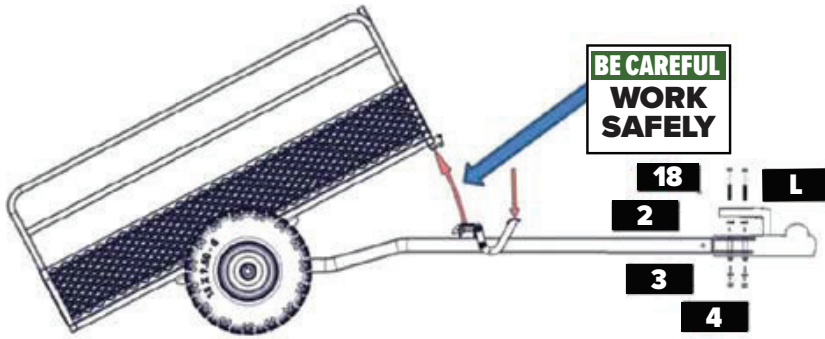
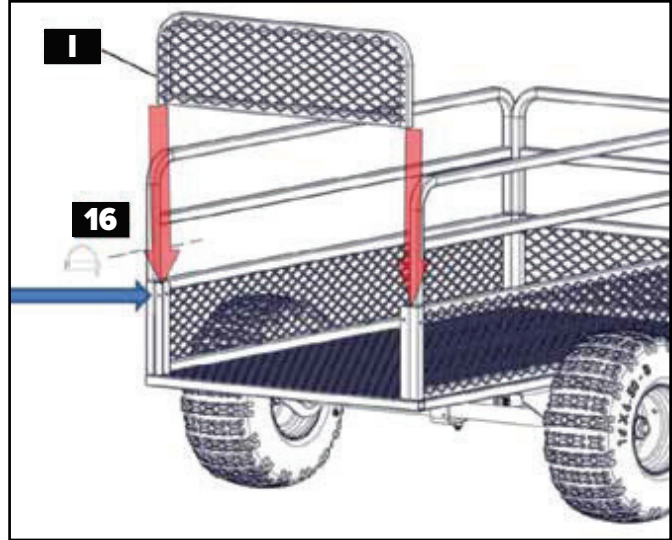

STEP 8

Install the coupler **L**, using hardware **2 3 4 18**.

| PARTS | | |
|-------|-----------------|-----|
| | NAME | QTY |
| A | Trailer Box | 1 |
| B | Axle Tube | 1 |
| C | Axle | 1 |
| D | Bracket | 2 |
| E | Tongue | 1 |
| F | U Connector | 1 |
| G | Front Rail | 1 |
| H | Side Rail | 2 |
| I | Tail Gate | 1 |
| J | Wheel | 2 |
| K | Front Connector | 1 |
| L | Coupler | 1 |

| HARDWARE | | | | | |
|----------|------------------|-----|----|-----------------|-----|
| | | QTY | | | QTY |
| 1 | Bolt M10x60 | 6 | 10 | Spring Washer 8 | 8 |
| 2 | Spring Washer 10 | 8 | 11 | Flat Washer 8 | 8 |
| 3 | Flat Washer 10 | 8 | 12 | Nut M8 | 8 |
| 4 | Nut M10 | 8 | 13 | Sleeve Tube | 2 |
| 5 | Bolt M12x85 | 1 | 14 | Flat Washer 19 | 4 |
| 6 | Spring Washer 12 | 1 | 15 | Cotter Pin 19 | 2 |
| 7 | Flat Washer 12 | 1 | 16 | D Lock Pin | 2 |
| 8 | Nut M12 | 1 | 17 | Bolt M8x55 | 2 |
| 9 | Bolt M8x40 | 6 | 18 | Bolt M10x65 | 2 |