



YAMoRC®
DIGITAL

YD7403 BOOSTER

UNIVERSAL BOOSTER 3,5A

QUICK START

(2025-04-II)



Designed by Karst Drenth
Made in Germany
Assembled in NL

Contents

[Description.....](#) 3

[Technical data.....](#) 3

[Mounting, dimensional drawing](#) 3

[Important notes.....](#) 4

[Hardware overview.....](#) 5

[Connection example of the YD6016LN-CS feedback unit on the 2-wire track, with YD7403 booster viaLocoNet®](#) 7

[Connection example of the YD6016LN-CS feedback unit on the 2-wire track, with YD7403 booster, Z21® via Roco® B-Bus®](#) 8

[Connection example YD7403 booster, feedback on 2-wire track via the CDE booster connection e.g. Lenz® LZxxx.....](#) 9

[Connection example YD7403 booster, feedback on 2-wire track via the track sniffer input.....](#) 10

[Connection example of the YD7403 booster to an Uhlenbrock® Intellibox®, Intellibox®2 or Intellibox® Basic.....](#) 11

[Warranty.....](#) 12



Description

- The **YD7403** is a DCC booster with a maximum output power of 3.5A. Railcom® is also supported.
Attention! The digital formats mfx®, Motorola and similar are not supported! The YD7403 is a pure DCC booster.
- The **YD7403** is configured "out of the box" so that the signal source (Loconet®, B-Bus®, CDE connection, track sniffer) is selected automatically.
- The "**ES-PGM Link**" connection allows the booster to be fully configured. This requires a YD9100 configuration module, for example.
- The **YD7403** can be switched on or off via a DCC accessory address (turnout address).
- A **polarity change** of the track out can be carried out via a DCC accessory address (turnout address).
Attention! This function does not replace a complete reverse loop module.
- The **YD7403** can report its current status to the control center via Loconet®.
- Various actions (global emergency stop, local emergency stop, global power on/off, local power on/off) can be assigned to the **multifunction button** on the YD7403 can be assigned.

Technical Data

Load capacity Track Out	3,5A peak, 2.75A continuous
Connection options	Loconet® B, Roco® B-Bus, CDE Booster Connection, Track Sniffer
Housing Dimensions	84 mm x 88 mm x 22 mm
Distance Between Holes	94,5 mm, 42,5 mm

Mounting

The YD6016LN-CS is mounted via the four mounting holes on the side of the housing.

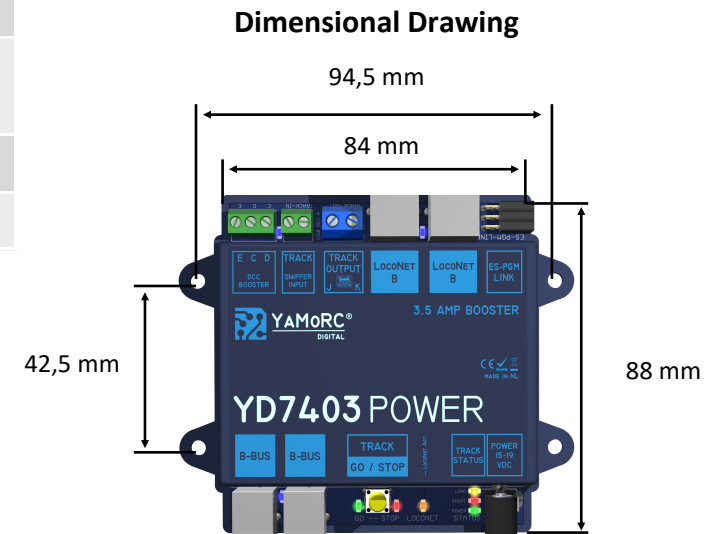

Important Notes

- The YD7403 is intended exclusively for operation on an electric model railway.
- The YD7403 is **not** a toy and is therefore **not** suitable for children under 14 years of age.
- **Never** leave the YD6016LN-CS operating without your presence. Please disconnect the product before leaving it unattended.
- Voltage sources (power supplies, transformers, etc.) **must comply** with the current VDE/EN and CE standards.
- The voltage sources used (power supplies, transformers) **must comply** with Protection Class 2. Failure to comply may result in serious damage to the YD6016LN-CS . The voltage sources must be marked with this symbol (illustrated below).



Further information on the **Protection Class 2** can be found here: <https://www.xppower.com/resources/blog/iec-protection-classes-for-power-supplies>

- The voltage source (DC) must not exceed a maximum power of **60W**.
- Voltage sources must be fused in such a way that a cable fire cannot occur in the event of a fault.
- A common earth connection of different voltage sources or circuits is **not** permitted. This will destroy the YD7403.
- It is essential to ensure that the wiring cross-section of the individual connections is sufficient.
- The connection terminals are designed for a cross-section of 0.75 mm².
- Connection work must always be carried out in a de-energised state. Disconnect or switch off power AC/DC and signal input.
- The YD7403 must **never** be installed near sources of intense heat, such as radiators or places exposed to direct sunlight. Therefore, install the YD7403 in a place with sufficient ventilation to be able to dissipate the waste heat.
- The YD7403 is designed for dry indoor use only. Therefore, do **not** operate the YD7403 outdoors or in environments with extreme fluctuations in temperature and humidity.
- Do **not** attempt to open the YD7403. Improperly performed actions can lead to the destruction of the YD7403 .

Hardware Overview

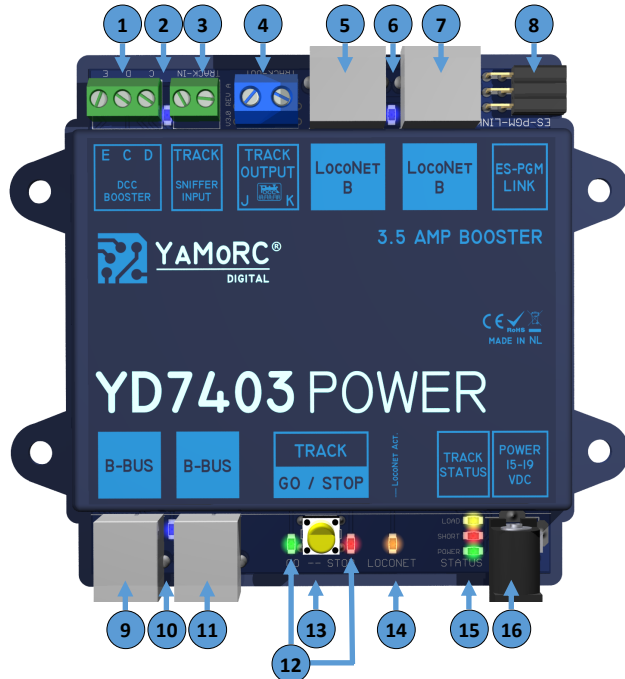

1	E C D DCC Booster	CDE booster connection to the control centre (note connection designation)
2	Blue LED	<ul style="list-style-type: none"> — Off if no signal is detected via CDE or track sniffer. *_* Flashes when a signal is detected via CDE or Track Sniffer, but CDE or Track Sniffer is not selected as the active signal source. * Lights up continuously when a signal is detected via CDE or Track Sniffer is detected and CDE or Track Sniffer is selected as the signal source.
3	Track Sniffer Input	Any DCC digital signal can be connected to this connection if no other connection option (CDE, Loconet [®] B, B-Bus [®]) to the control centre is possible.
4	Track Out	Connection to the track
5	Loconet[®] B Connection 1	A Loconet [®] connection cable can be used to establish a connection to the control centre via Loconet [®] B.

6	Blue LED	<ul style="list-style-type: none"> — Off if no signal is detected via Loconet[®]. **** Flashes when a signal is detected via Loconet[®] but Loconet[®] is not selected as the active signal source. * Lights up continuously when a signal is detected via Loconet[®] and Loconet[®] is selected as the signal source.
7	Loconet[®] B Connection 2	A Loconet [®] connection cable can be used to establish a connection to the control centre via Loconet [®] B.
8	ES-PGM Link	YaMoRC programming adapter connection Firmware updates and advanced programming can be carried out with the YaMoRC programming adapter.
9	B-Bus[®] Connection 1	A B-Bus [®] connection cable can be used to establish a connection to the centre can be established via the B-Bus [®] .
10	Blue LED	<ul style="list-style-type: none"> — Off if no signal is detected via the B-Bus[®]. **** Flashes when a signal is detected via the B-Bus[®] but the B-Bus[®] is not selected as the active signal source. * Lights up continuously when a signal is detected via the B-Bus[®] and the B-Bus[®] is selected as the signal source.
11	B-Bus[®] Connection 2	A B-Bus [®] connection cable can be used to establish a connection to the centre can be established via the B-Bus [®] .
12	Status Anzeige Green LED Red LED	<ul style="list-style-type: none"> * Green LED lights up continuously Track Out activated. **** Green LED flashes EMERGENCY STOP recognised by the control centre. **** Red LED flashes. Short circuit detected at the Track Out *_* Green and Red LEDs flash alternately. No valid input signal input signal detected via Loconet[®], B-Bus[®], CDE or Track Snifer.

Hardware Overview

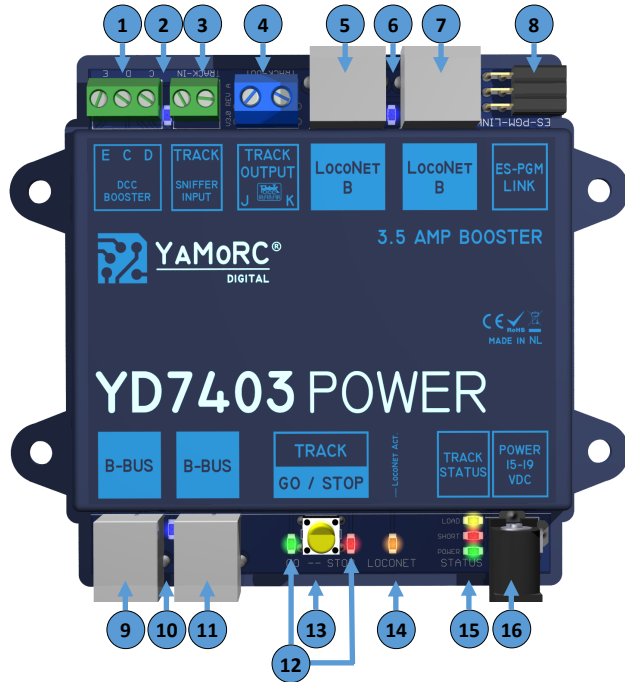

13	Booster button	Various actions can be triggered with this button. By default, the action Power on/off is global (switch the control centre and all boosters on or off)
14	Orange LED LocoNet[®] Akt.	Indicates that data is being exchanged via LocoNet [®] .
15	Status Gelbe LED Rote LED Grüne LED	<ul style="list-style-type: none"> * Yellow LED lights up. Load on Track Out below 90%. (LED becomes brighter under load) **** Yellow LED flashes. Load on Track Out greater than 90%. **** Green Led flashes. Power supply available. * Red LED lights up. Short circuit detected at the Track Out.
16	Power 15-19 VDC	<p>Connection DC (direct voltage) power supply unit, protection class</p> <p>25,5x2,1mm Socket connector</p> <p>Min: 15VDC</p> <p>Max: 19VDC</p> <p>Max: 60W</p>

Connection example of the YD6016LN-CS feedback unit on the 2-rail track, with YD7403 booster via LocoNet®

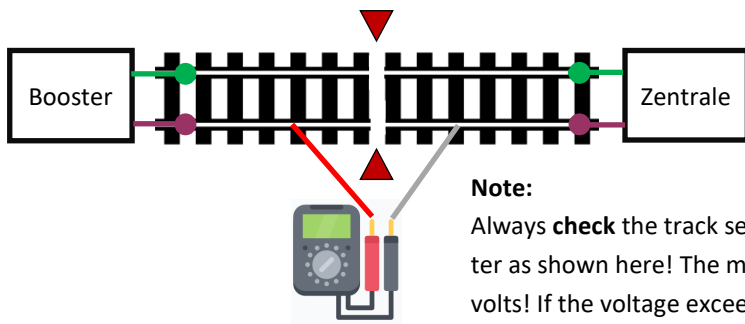
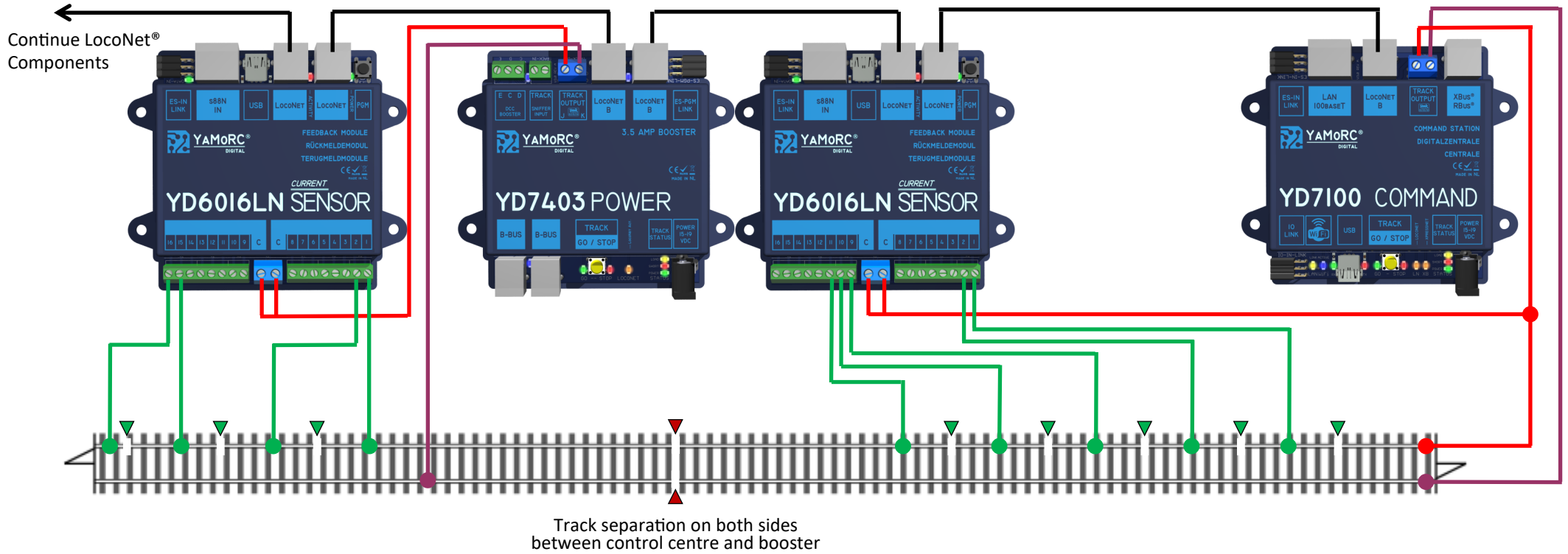

Always **check** the track separation between the control centre and booster as shown here! The measured value displayed must not exceed 0.8 volts! If the voltage exceeds 0.8V, the wiring and the voltage setting on the power supply unit must be checked.

Caution!

All connection work must always be carried out in a de-energised state. **Disconnect** the power supply from the mains and switch off the control centre!

Connection example of the YD6016LN-CS feedback unit on 2-rail track, with YD7403 booster, Z21[®] via Roco[®] B-Bus[®]

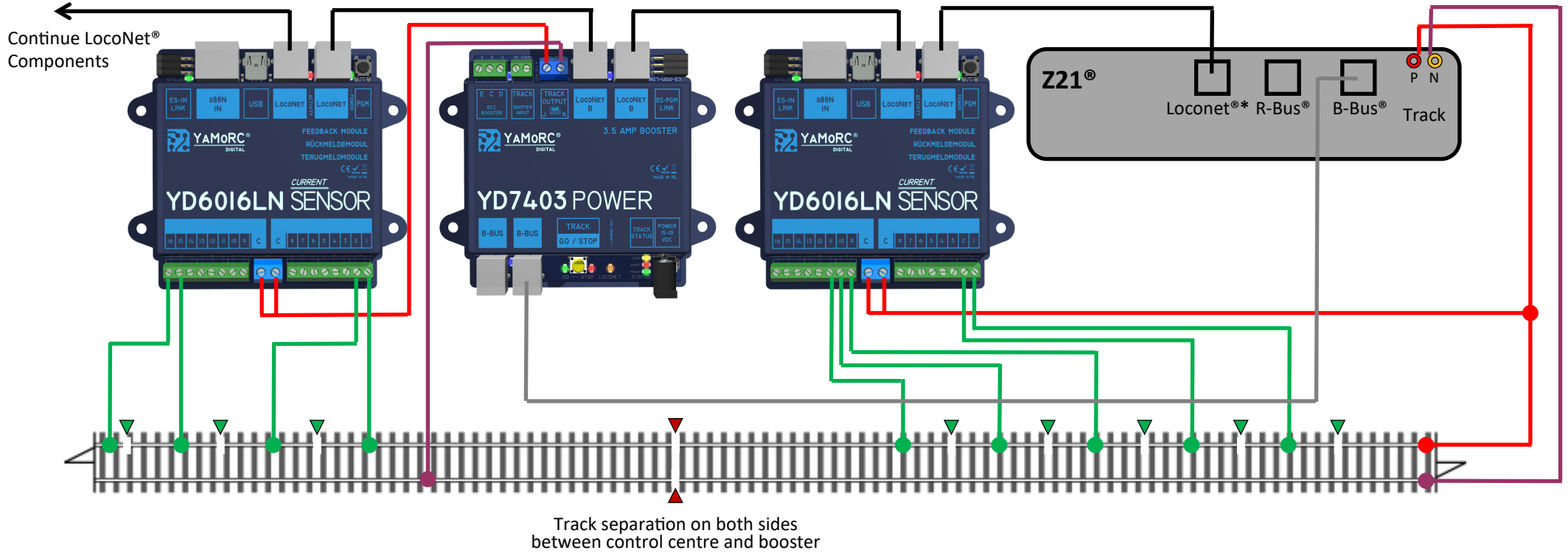

* Galvanic isolation of the LocoNet[®] in the YD7403 means that the YD7403 can be safely connected to the LocoNet[®] of the Z21 via LocoNet[®]. This makes it possible to control the YD7403 and query status messages via LocoNet[®].

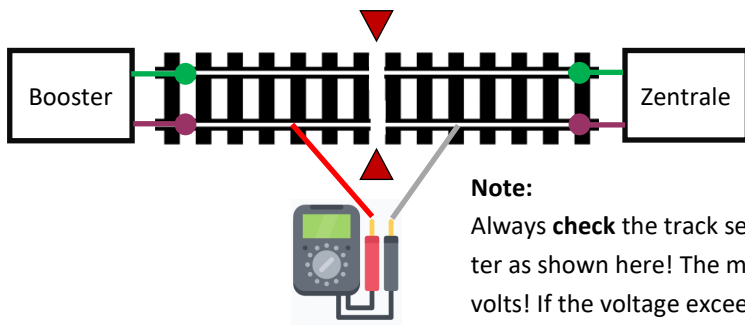

Note:

Always **check** the track separation between the control centre and booster as shown here! The measured value displayed must not exceed 0.8 volts! If the voltage exceeds 0.8V, the wiring and the voltage setting on the power supply unit must be checked.

Caution!

All connection work must always be carried out in a de-energised state. **Disconnect** the power supply from the mains and switch off the control centre!

Connection example YD7403 booster, feedback on the 2-rail track via the CDE booster connection e.g. Lenz[®] LZxxx

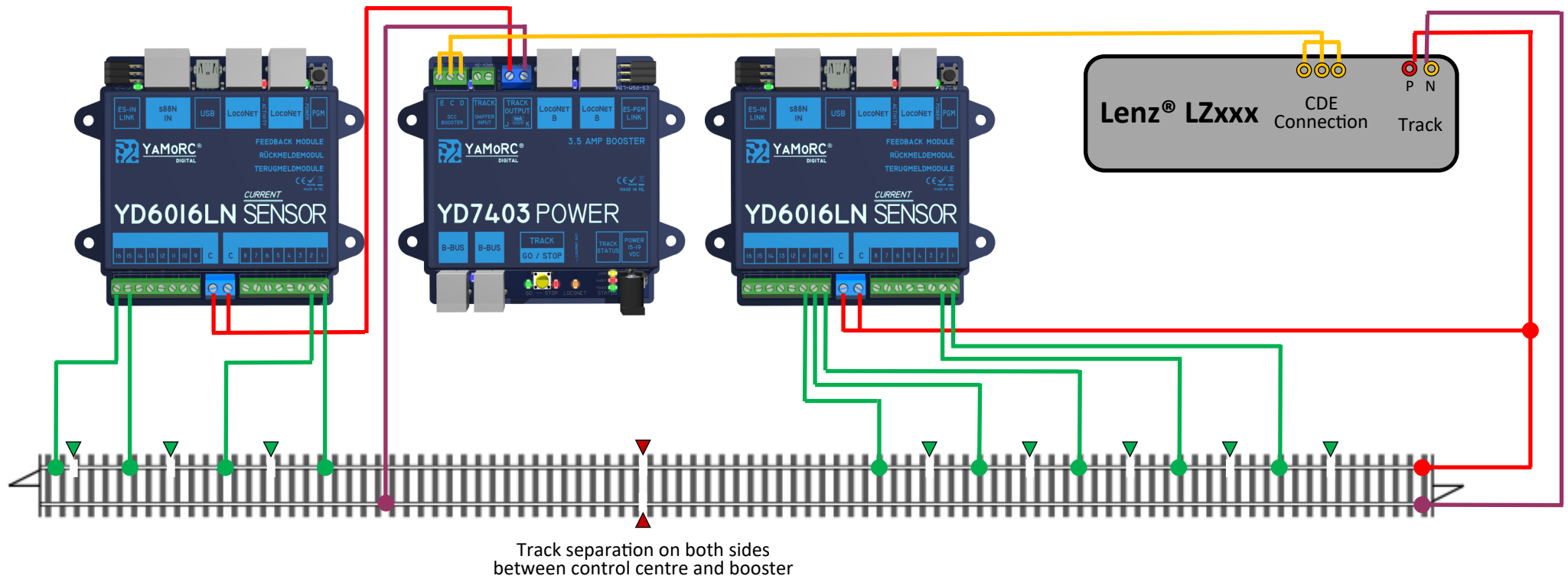

Attention! Only the connection via the CDE terminals of the control centre to the YD7403 is shown here. The YD6016LN-CS only serve as an example of how the connection to the track can look.

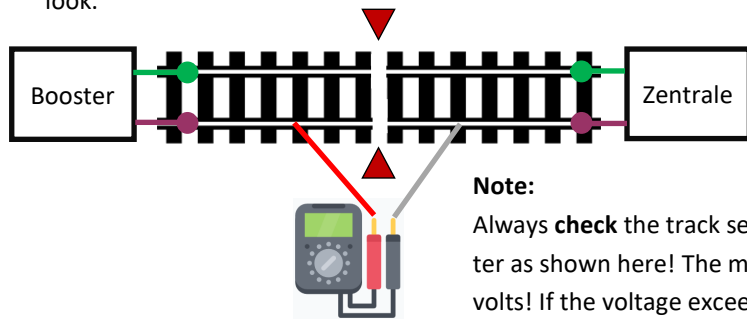

Note:
Always **check** the track separation between the control centre and booster as shown here! The measured value displayed must not exceed 0.8 volts! If the voltage exceeds 0.8V, the wiring and the voltage setting on the power supply unit must be checked.

Caution!
All connection work must always be carried out in a de-energised state. **Disconnect** the power supply from the mains and switch off the control centre!

Connection example YD7403 booster, feedback on the 2-rail track via the track sniffer input

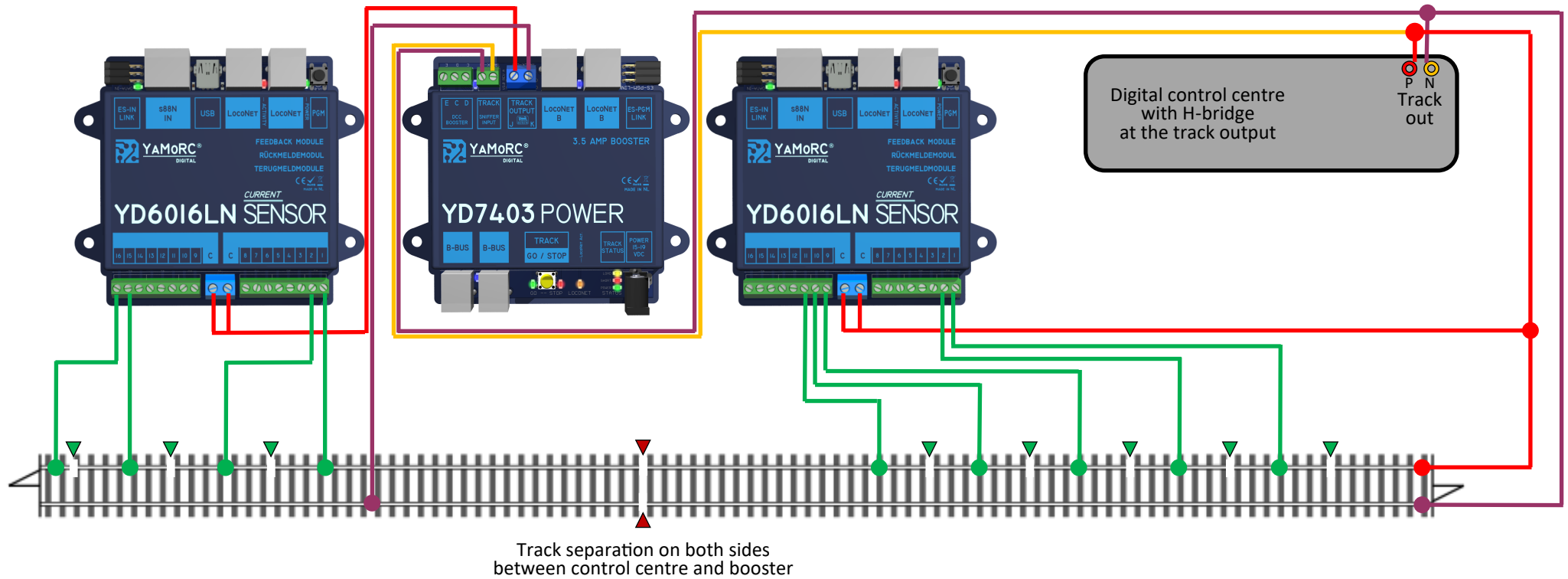

Attention! Only the connection via the track out terminals of the control centre and the track sniffer input of the YD7403 is shown here. The YD6016LN-CS only serve as an example of how the connection to the track can look.

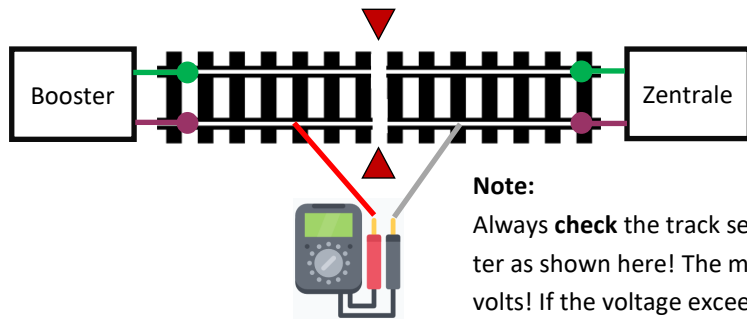

Note:
Always **check** the track separation between the control centre and booster as shown here! The measured value displayed must not exceed 0.8 volts! If the voltage exceeds 0.8V, the wiring and the voltage setting on the power supply unit must be checked.

Caution!
All connection work must always be carried out in a de-energised state. **Disconnect** the power supply from the mains and switch off the control centre!

Connection example of the YD7403 booster to an Uhlenbrock® Intellibox®, Intellibox®2 or Intellibox® Basic

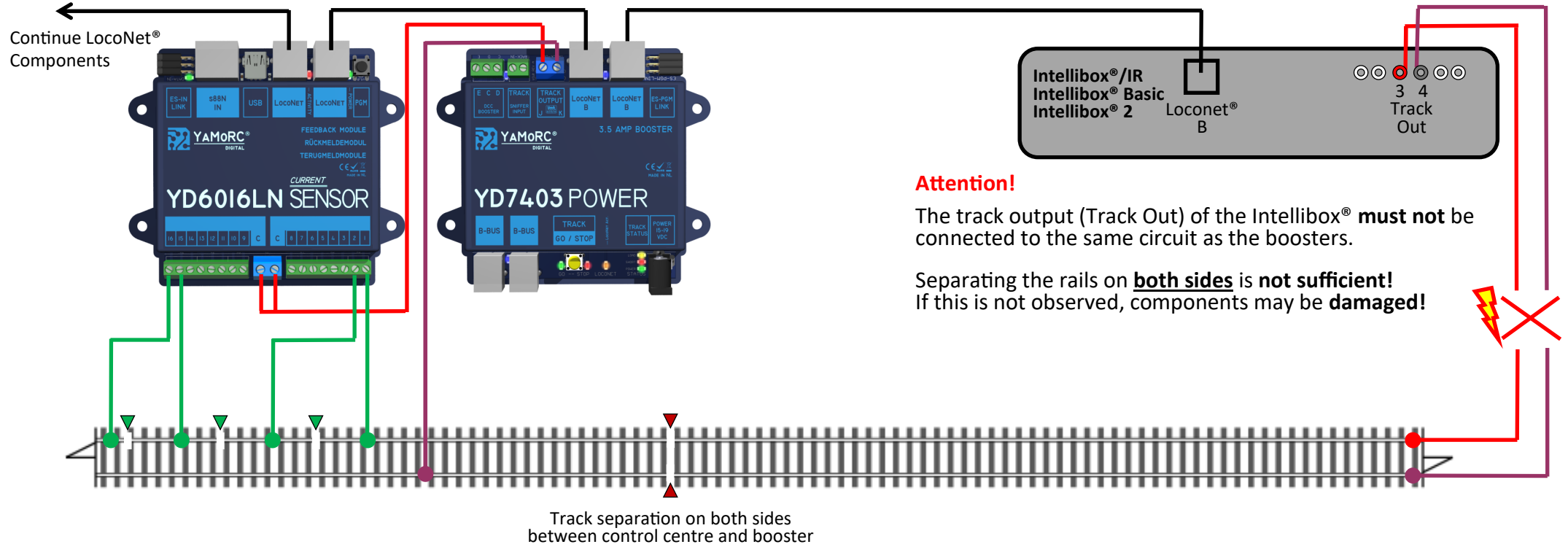

Attention!

The track output (Track Out) of the Intellibox® **must not** be connected to the same circuit as the boosters.

Separating the rails on **both sides** is **not sufficient!**
If this is not observed, components may be **damaged!**

Caution!

All connection work must always be carried out in a de-energised state. **Disconnect** the power supply from the mains and switch off the control centre!

Warranty

24 months warranty from date of purchase

Dear Customer,

Congratulations on your purchase from YaMoRC. YaMoRC's high quality products have been manufactured using modern manufacturing processes and have been subjected to careful quality control and tests.

Therefore, when purchasing a YaMoRC product, the company YaMoRC grants you a manufacturer's warranty of 24 months from the date of purchase in addition to the national warranty rights to which you may be legally entitled to, from your YaMoRC specialist dealer as contractual partner.

Warranty conditions:

This warranty applies to all YaMoRC products purchased from a YaMoRC dealer. Warranty services are only provided if proof of purchase is presented. Proof of purchase is the purchase receipt from the YaMoRC specialist dealer. It is therefore recommended to keep your purchase receipt safe.

Content of the guarantee/exclusions:

The warranty includes, at YaMoRC's discretion, the free repair or free replacement of the defective part, which can be proven to be due to design, manufacturing, material or transport faults. For this purpose, you must send the decoder to us properly stamped. Further claims are excluded.

The warranty claims are void:

1. in the case of general wear and tear at expected locations (e.g. screw terminals).
2. in the case of modification of YaMoRC products with parts not approved by the manufacturer.
3. in the case of modification of parts, especially by opening the housing.
4. if the product is used for purposes other than those intended by the manufacturer.
5. if the instructions given by YaMoRC in the operating manual have not been thoroughly read by the user & risked mis-use of the product.

The warranty period is not extended by the repair or replacement delivery. Warranty claims can only be made to your dealer, enclosing any warranty certificate, proof of purchase and a description of the fault. Products sent directly to YaMoRC will neither be treated nor returned free of charge.



Drenth Design & Consulting B.V.

Glazeniershorst 209

NL-7328 TJ APELDOORN

Liability: Drenth Design & Consulting B.V.

Phone: +31643392605

E-Mail: ddc@yamorc.com

Directors: Karst Drenth

Trade register: 72184728

VAT No/Tax ID: NL-859019901B01