

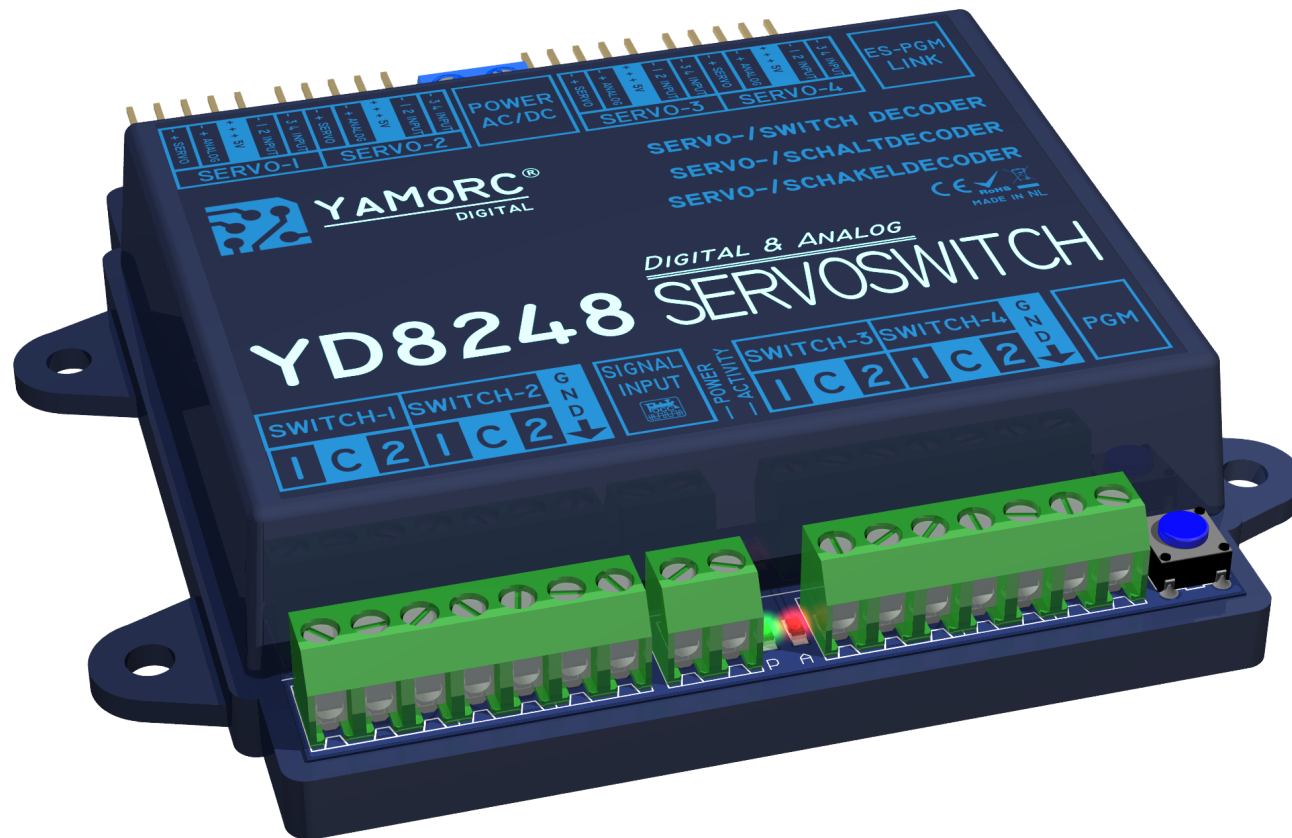

YAMoRC®
DIGITAL

YD8248 SERVO SWITCH

SEVODECODER FOR A MAXIMUM OF 12 RC SERVOS QUICK START



(2025-04-10)



Designed by Karst Drenth
Made in Germany
Assembled in NL

Contents

[Description](#) 3

[Technical data.....](#) 4

[Assembly, dimensional drawing.....](#) 4

[Important notes.....](#) 5

[Hardware overview.....](#) 6

[Connecting the power supply.....](#) 10

[Connecting the servos to the YD8248 and the adapte
YD8290, YD8291.....](#) 11

[Connection of servos, buttons, potentiometers and light barriers
on the YD8248.....](#) 13

[Configuring the accessory address \(switch address\).....](#) 14

[Warranty.....](#) 15

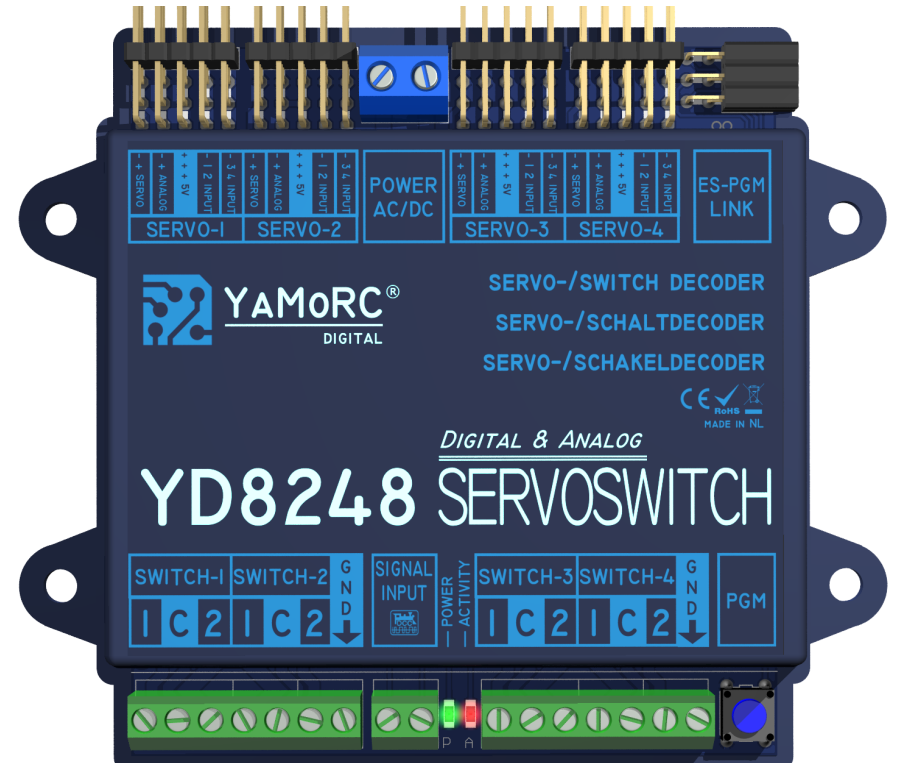

Description

- When the **YD8248** is delivered (out of the box), four RC servos can be connected directly.
- The switching outputs of the YD8248 are pre-assigned with two aspects for light signals in the as-delivered state (out of the box).
- The **YD7842** "Standalone" can be controlled without a DCC central unit via the existing analogue and digital inputs.
- The existing switching outputs of the **YD8248** can be used for frog polarisation using the **YD8290** adapter. This may require adjustments to the configuration.
- With the **YD8291** adapter, the **YD8248** can be extended by a further 8 RC servos. The **YD8248** can therefore control a maximum of 12 RC servos. This may require adjustments to the configuration.
- The **YD8248** can control RC servos with a travel of 90° and 180°. Of course, linear and endless servos can also be controlled.
- The **YD8248** is not designed for the operation of motorised point machines (e.g. mtb®, Conrad®, Lux®, Hoffman®, Tillig®, Fulgurex®, etc.). Please use the **YD8116** for this purpose!
- The **YD8248** has a power management system that ensures error-free switching of the outputs at all times. This effectively prevents the loss of switching commands.
- The accessory address (turnout address) is configured simply by pressing the programming button. We have deliberately decided to keep the configuration as simple as possible, which is why no further settings are required on the **YD8248** for normal operation. Only a freely selectable accessory address (turnout address) must be assigned as the start address. The **YD8248** then automatically assigns the seven subsequent accessory addresses.
- The **YD8248** is delivered with the accessory addresses (switch addresses) 1 - 8 pre-assigned.
- For control centres that can generate several protocols simultaneously, it is essential to ensure that the accessory addresses (turnout addresses) occupied by the **YD8248** are preset as DCC addresses. accessory addresses (turnout addresses) are preset as **DCC addresses**.
- Alternatively, the **YD8248** can be conveniently configured via the "ES-PGM Link" connection. Please note that this requires either a programming module (YD9100, YD9101) or a YaMoRC module with an "ES-IN Link" connection (e.g. YD6016LN-xx) is required. Through the configuration via the "ES-Link", it is possible to freely assign the accessory addresses, change the switching pulse duration, adapt or carry out the address switching matrix and the inversion of the switching term.
- **Attention!** If a firmware update is carried out via "ES-Link", the current configuration of the **YD8248** should be saved in a freely selectable directory using the "Export data" function.

Technical data:

Number of outputs	4 servo outputs (as delivered) A maximum of 12 servo outputs can be connected to the YD8291 adapter. 8 switching outputs (short-circuit-proof up to 2.5A) A frog polarisation is possible with the YD8290 adapter.
Number of digital inputs	8 for controlling the servos via buttons, for example.
Number of analogue inputs	4 to control the servos via a potentiometer.
Digital format	DCC
Address range Accessory address	1 - 2048
Input voltage DC (direct voltage)	min. 12 VDC (recommendation) max. 19 VDC
Input voltage AC (alternating voltage)	min. 10 VAC max. 16 VAC We advise against using AC voltage sources (transformers). This can lead to servo tremors and unwanted movements with some servo types.
Dimensions of the housing	84 mm x 88 mm x 22 mm
Hole spacing	94,5 mm, 42,5 mm

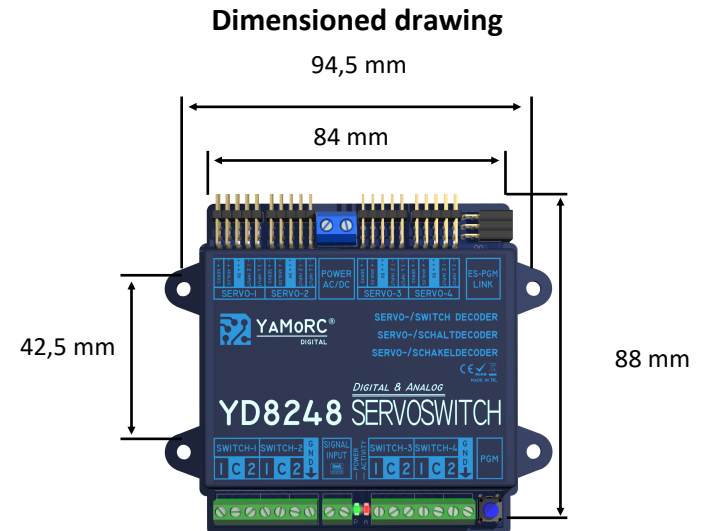

Montage



The YD8248 is mounted using the four mounting holes on the side of the housing.

Important notes:

- The YD8248 is intended exclusively for operation on an electric model railway.
- The YD8248 is not a toy and is therefore not suitable for children under the age of 14.
- Never operate the YD8248 unattended.
- Power sources (power supply units, transformers, etc.) must comply with the current VDE/EN and CE standards.
- The power sources used (power supply units, transformers) must comply with protection class 2. Failure to do so may result in serious damage to the YD8248. The power sources must be labelled with this symbol. Further information on the protection class can be found here, for example: <https://www.google.com/search?q=schutzklasse+2&oq=schutzklasse+2> 
- Direct voltage sources (**DC**) must not exceed a maximum power of **60W**.
- AC voltage sources (**AC**) must not exceed a maximum output current of **3A**.
- Voltage sources must be fused in such a way that a cable fire cannot occur in the event of a fault.
- AC transformers must not exceed a maximum output voltage of 16 VAC. The YD8248 rectifies AC voltage internally and always provides DC voltage at the output terminals. The polarity of the output terminals (- + -) must be observed!
- A common earth connection of different voltage sources or circuits is not permitted. This will destroy the YD8248.
- It is essential to ensure that the wiring cross-section of the individual connections is sufficient.
- The connection terminals for power are designed for a cross-section of 0.75 mm². All other terminals are designed for a cross-section of 0.5 mm².
- Connection work must always be carried out in a de-energised state. Disconnect or switch off the AC/DC power and signal input.
- The YD8248 must never be installed near strong heat sources, such as radiators or places exposed to direct sunlight be installed. Therefore, install the YD8248 in a location with sufficient ventilation to dissipate the waste heat.
- The YD8248 was developed exclusively for dry indoor spaces. Therefore, do not operate the YD8248 in environments with large fluctuations in temperature and humidity or outdoors.
- Do not attempt to open the YD8248. Improper actions can lead to the destruction of the YD8248.

Hardware overview

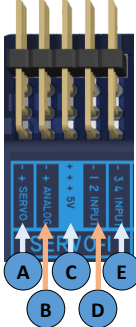

<p>1</p> 	<p>Servo 1</p>	<p>A Servo Impuls + - Analogue + - C 5V + + + Input 2 D 1 - Input 4 E 3 -</p>	<p>Connector plug for the first servo First pin from top pulse (cable colour e.g. yellow, white, orange) Positive pole of the servo (cable colour e.g. red) Negative pole of the servo (cable colour e.g. black, brown)</p> <p>A potentiometer with values between 5kOhm and 10kOhm can be connected here to control the servo without a DCC control centre.</p> <p>Connection for the potentiometer wiper (first pin from the top) Potentiometer connection at the beginning of the resistor track Potentiometer end of resistance track connection</p> <p>Five volt supply voltage (+) e.g. for light barriers or other sensors.</p> <p>For example, buttons or 5V light barriers can be connected to the input pins to control the servos without a DCC control centre.</p> <p>Digital inputs 2 and 1 (minus switching) Digital input 2 (first pin from top) Digital input 1 Negative pole for inputs 2 and 1</p> <p>Digital inputs 4 and 3 (minus switching) Digital input 4 (first pin from top) Digital input 3 Negative pole for inputs 4 and 3</p>
<p>2</p> 	<p>Servo 2</p>	<p>A Servo Impuls + - Analogue + - C 5V + + + Input 2 D 1 - Input 4 E 3 -</p>	<p>Connector plug for the first servo First pin from top pulse (cable colour e.g. yellow, white, orange) Positive pole of the servo (cable colour e.g. red) Negative pole of the servo (cable colour e.g. black, brown)</p> <p>A potentiometer with values between 5kOhm and 10kOhm can be connected here to control the servo without a DCC control centre.</p> <p>Connection for the potentiometer wiper (first pin from the top) Potentiometer connection at the beginning of the resistor track Potentiometer end of resistance track connection</p> <p>Five volt supply voltage (+) e.g. for light barriers or other sensors.</p> <p>For example, buttons or 5V light barriers can be connected to the input pins to control the servos without a DCC control centre.</p> <p>Digital inputs 2 and 1 (minus switching) Digital input 2 (first pin from top) Digital input 1 Negative pole for inputs 2 and 1</p> <p>Digital inputs 4 and 3 (minus switching) Digital input 4 (first pin from top) Digital input 3 Negative pole for inputs 4 and 3</p>

Hardware overview



3	Power AC/DC	<p>Supply voltage connection</p> <p>DC voltage min. 12 VDC (Recommendation) max. 19 VDC / 60W</p> <p>AC voltage min. 10 VAC max. 16 VAC / 3A</p> <p>We advise against using AC voltage sources (transformers). This can lead to servo tremors and unwanted movements with some servo types.</p>
4	Servo 3	<div style="display: flex; align-items: center;">  <div style="margin-left: 10px;"> <p>A Servo Impuls</p> <p>First pin from top pulse (cable colour e.g. yellow, white, orange) + Positive pole of the servo (cable colour e.g. red) - Negative pole of the servo (cable colour e.g. black, brown)</p> <p>B</p> <p>A potentiometer with values between 5kOhm and 10kOhm can be connected here to control the servo without a DCC control centre.</p> <p>Analog</p> <p>Connection for the potentiometer wiper (first pin from the top) + Potentiometer connection at the beginning of the resistor track - Potentiometer end of resistance track connection</p> <p>C 5V</p> <p>Five volt supply voltage (+) e.g. for light barriers or other sensors.</p> <p>D Input 2</p> <p>Digital inputs 2 and 1 (minus switching) 1 Digital input 2 (first pin from top) - Digital input 1 - Negative pole for inputs 2 and 1</p> <p>E Input 4</p> <p>Digital inputs 4 and 3 (minus switching) 4 Digital input 4 (first pin from top) 3 Digital input 3 - Negative pole for inputs 4 and 3</p> </div> </div>

Hardware overview



5		Servo 4		
		A	Servo Impuls	Connector plug for the first servo First pin from top pulse (cable colour e.g. yellow, white, orange) Positive pole of the servo (cable colour e.g. red) Negative pole of the servo (cable colour e.g. black, brown)
		B	Analog	A potentiometer with values between 5kOhm and 10kOhm can be connected here to control the servo without a DCC control centre.
		C	5V	Connection for the potentiometer wiper (first pin from the top) Potentiometer connection at the beginning of the resistor track Potentiometer end of resistance track connection Five volt supply voltage (+) e.g. for light barriers or other sensors.
		D	Input 2	For example, buttons or 5V light barriers can be connected to the input pins to control the servos without a DCC control centre. Digital inputs 2 and 1 (minus switching) Digital input 2 (first pin from top) Digital input 1 Negative pole for inputs 2 and 1
		E	Input 4	Digital inputs 4 and 3 (minus switching) Digital input 4 (first pin from top) Digital input 3 Negative pole for inputs 4 and 3
6	ES-PGM Link			YD9100 YaMoRC programming adapter connection The YD9100 can be used to carry out configuration and any firmware updates.
7	Switch 1		1 C 2	Output 1 connection Common connection positive pole + Connection output 2
8	Switch 2		1 C 2	Output 1 connection Common connection positive pole + Connection output 2
9	GND			GND connection adapters YD8290, YD8291
10	Signal Input			DCC track signal connection (track voltage)
11	Power	Green LED		Supply voltage display **** Green LED YD9100 connected, no voltage present at Power *.*.* Green LED Power supply on Power available
	Activiy	Red LED		Display activity ***** Red LED One pulse of the LED an accessory address is activated

Hardware overview

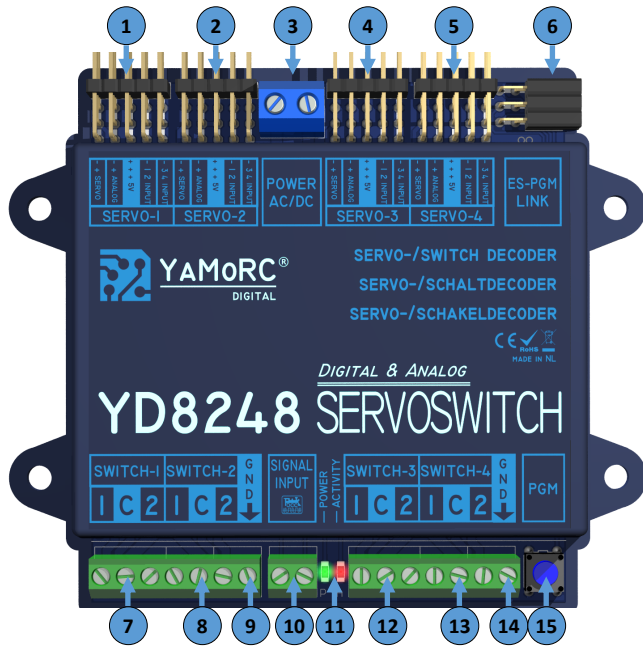

12	Switch 1	1	Output 1 connection
		C	Common connection positive pole +
		2	Connection output 2
13	Switch 2	1	Output 1 connection
		C	Common connection positive pole +
		2	Connection output 2
14	GND		GND connection adapters YD8290, YD8291
15	PGM		Programming button

Connecting the power supply

The YD8248 can either be supplied with power directly from the control centre or with a separate DC power supply unit (recommended) or AC transformer.

Power supply of the YD8248 directly via the digital control centre.

Attention: If a 6016LN-xx is used to configure the YD8248 is used to configure the YD8248, the connection from Power AC/DC to the Track Out of the control centre or a booster must be disconnected.

Power supply of the YD8248 via a separate power supply unit (DC) or a transformer (AC) (not recommended). The required output current of the power supply unit depends on the RC servos used. Some RC servos can have a high current requirement that a power supply unit with 3A is required.

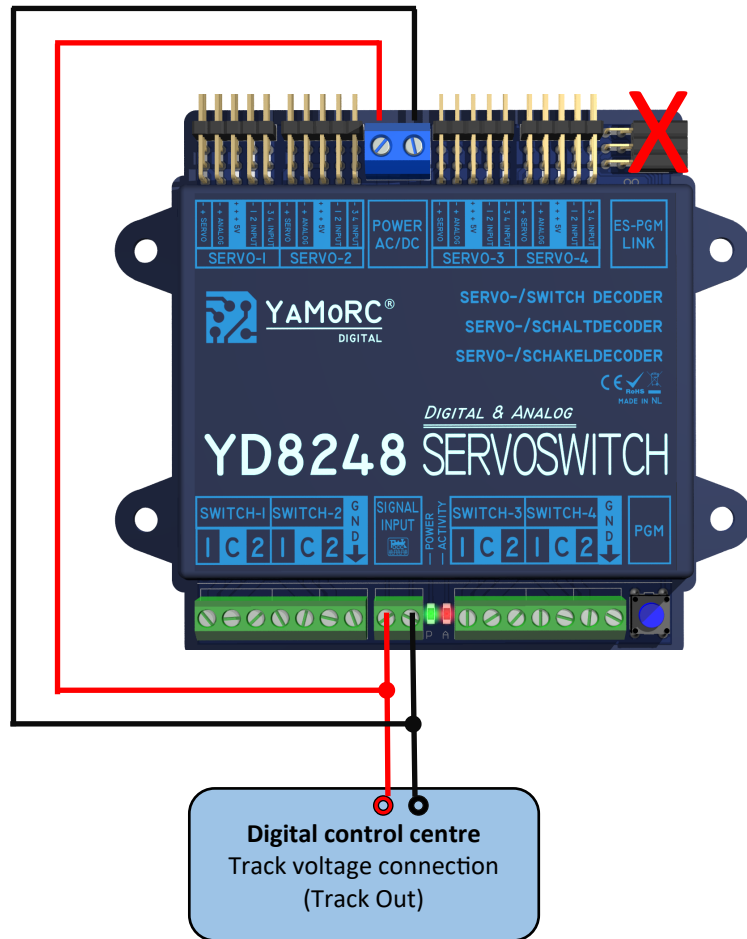

Voltage source
Power supply (DC) 12-19 VDC
Transformer (AC) 10- 16 VAC
(not recommended)

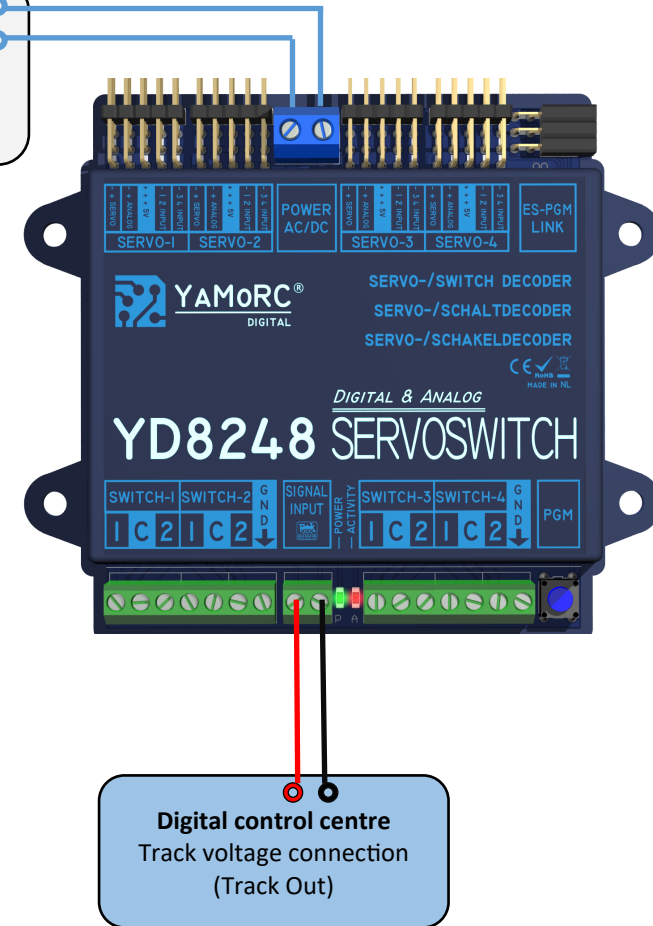

Caution!

All connection work on the YD8248 must always be carried out in a de-energised state. Disconnect the power supply from the mains and switch off the control centre!

Connecting the servos to the YD8248 and the YD8290, YD8291 adapters

Turnout polarisation with one relay (K1) of the YD8290 per turnout.

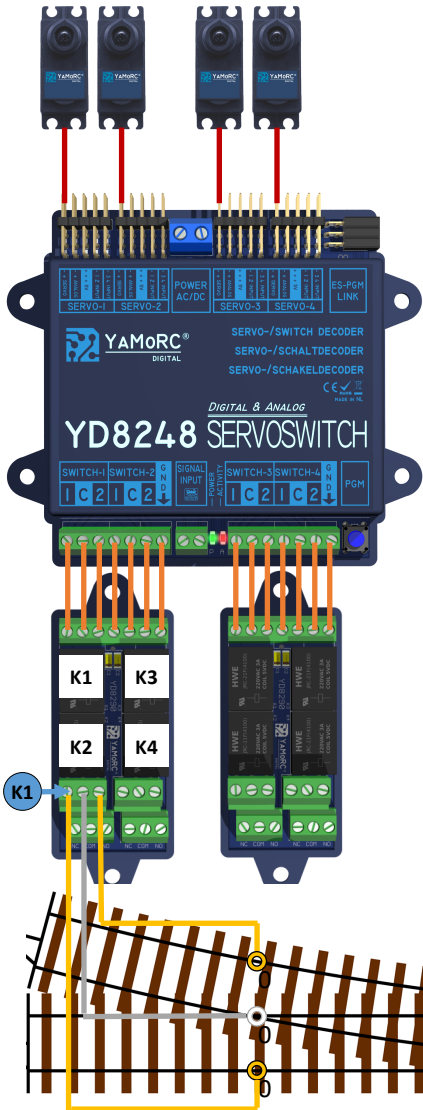

Each YD8290 can thus be used to easily polarise four turnouts. The YD8290 is available as an option.

Turnout polarisation with two relays (K1 and K2) of the YD8290 per turnout.

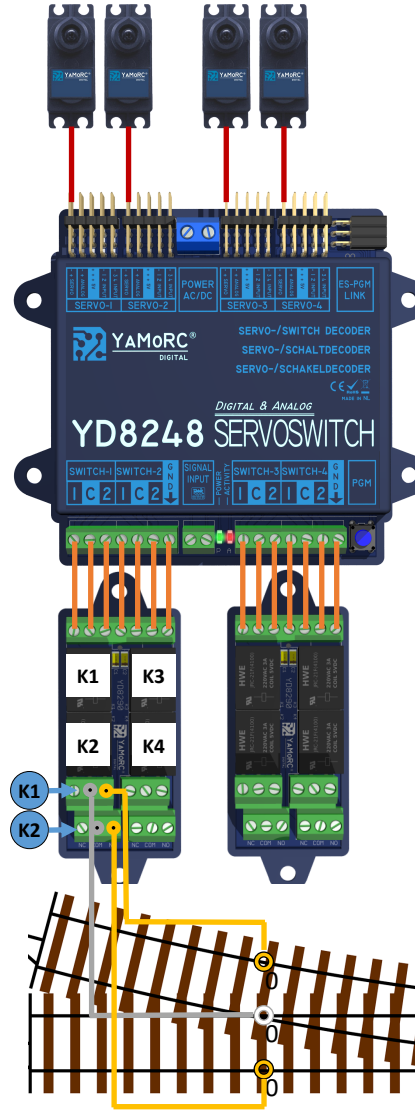

Two turnouts can be polarised with each YD8290. With this connection, the centre of the turnout is de-energised when switching, which can be an advantage, especially with problem turnouts. The YD8290 is available as an option.

Caution!

All connection work on the YD8248 must always be carried out in a de-energised state. Disconnect the power supply from the mains and switch off the control centre!

Connecting the servos to the YD8248 and the YD8290, YD8291 adapters



Four RC servos can be connected and controlled on each YD8291. This means that twelve RC servos can be operated on one YD8248 with two YD8291s. The YD8291 is available as an option.

Four RC servos per YD8291 possible.

Caution!

All connection work on the YD8248 must always be carried out in a de-energised state. Disconnect the power supply from the mains and switch off the control centre!

Connection of servos, buttons, potentiometers and light barriers to the YD8248

Schematic diagram of servo connection.

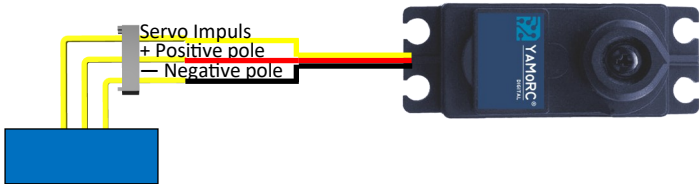

Schematic diagram Connection of push-buttons to control the assigned RC servos at the corresponding connection.

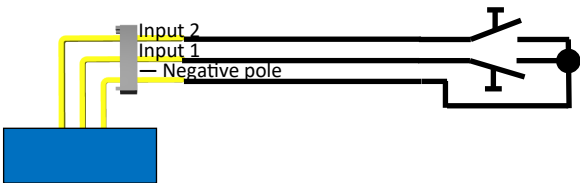

Schematic diagram Connection of potentiometers to control the assigned RC servos at the corresponding connection.

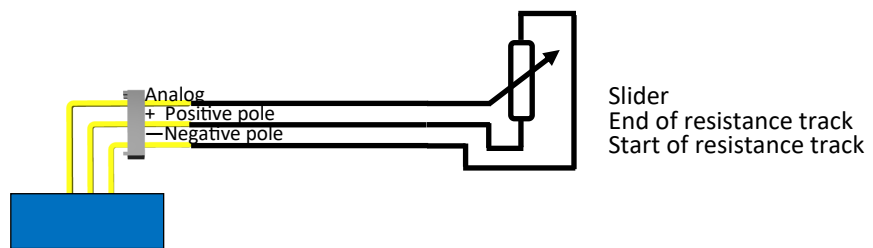

Schematic diagram Connection of sensors (e.g. light barriers) to control the assigned RC servos at the corresponding connection.

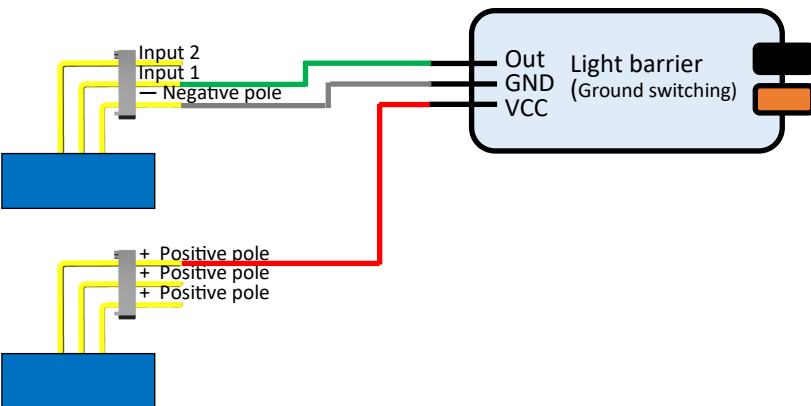

Caution!

All connection work on the YD8248 must always be carried out in a de-energised state. Disconnect the power supply from the mains and switch off the control centre!

Configuring the first accessory address (switch address)

YaMoRC has decided to make the configuration of the **YD8248** as **simple as possible**. For this reason, the **YD8248** does not have the CV programming that used to be standard. Configuration is carried out conveniently via the **YD9100** configuration module. Out of the box, the YD8248 is able to RC servos and four signals, each with two LEDs. However, the simple assignment of the DCC accessory address via a DCC accessory address only makes sense if the **YD8248** is in the as-delivered state.

If you have any questions, please contact our service department. We will certainly find a solution for you.

Configuring the first accessory address (switch address)

1. Connect the **power supply** to the power input. 1
2. Connect the **signal input** to the track voltage output of the control centre 2
3. Switch on the power supply (Power) and the control panel.
4. Call up the points control panel of the control centre, hand-held controller or app and the accessory address that is to be assigned as the **first** accessory address for the YD8248. Do not perform a switching operation yet!
(Please refer to the documentation for your control centre, hand-held controller or app for the exact procedure for calling up a points control panel).
5. Press the programming button to set the YD8248 to configuration mode. 3 The red LED lights up continuously to indicate that the YD8248 is in configuration mode.
6. Press the accessory address called up under point 4 once. The following seven accessory addresses are assigned automatically. This means that the YD8248 occupies eight consecutive accessory addresses.
(For the exact procedure for switching an accessory address, please refer to the documentation for your control centre, manual controller or app).
7. The assignment of the accessory addresses is complete and the YD8248 automatically exits configuration mode. (The red LED goes out.)

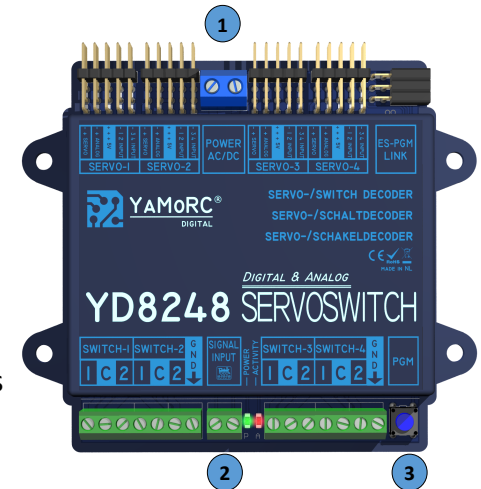

Example:

- Press the programming button on the YD8248 -> Switch accessory address 1 -> The YD8248 occupies accessory addresses 1,2,3,4,5,6,7,8
- Press the programming button on the YD8248 -> Switch accessory address 9 -> The YD8248 occupies accessory addresses 9,10,11,12,13,14,15,16
- Press the programming button on the YD8248 -> Switch accessory address 20 -> The YD8248 occupies accessory addresses 20,21,22,23,24,25,26,27

Note:

For control centres that can generate several protocols simultaneously, it is essential to ensure that the accessory addresses occupied by the YD8248 are preset as **DCC addresses**.

Caution!

All connection work on the YD8248 must always be carried out in a de-energised state. Disconnect the power supply from the mains and switch off the control centre!

Warranty

24 months warranty from date of purchase

Dear Customer,

Congratulations on your purchase from YaMoRC. YaMoRC's high quality products have been manufactured using modern manufacturing processes and have been subjected to careful quality control and tests.

Therefore, when purchasing a YaMoRC product, the company YaMoRC grants you a manufacturer's warranty of 24 months from the date of purchase in addition to the national warranty rights to which you may be legally entitled to, from your YaMoRC specialist dealer as contractual partner.

Warranty conditions:

This warranty applies to all YaMoRC products purchased from a YaMoRC dealer. Warranty services are only provided if proof of purchase is presented. Proof of purchase is the purchase receipt from the YaMoRC specialist dealer. It is therefore recommended to keep your purchase receipt safe.

Content of the guarantee/exclusions:

The warranty includes, at YaMoRC's discretion, the free repair or free replacement of the defective part, which can be proven to be due to design, manufacturing, material or transport faults. For this purpose, you must send the decoder to us properly stamped. Further claims are excluded.

The warranty claims are void:

1. in the case of general wear and tear at expected locations (e.g. screw terminals).
2. in the case of modification of YaMoRC products with parts not approved by the manufacturer.
3. in the case of modification of parts, especially by opening the housing.
4. if the product is used for purposes other than those intended by the manufacturer.
5. if the instructions given by YaMoRC in the operating manual have not been thoroughly read by the user & risked mis-use of the product.

The warranty period is not extended by the repair or replacement delivery. Warranty claims can only be made to your dealer enclosing any warranty certificate, proof of purchase and a description of the fault. Products sent directly to YaMoRC products will neither be treated nor returned free of charge.



Drenth Design & Consulting B.V.

Glazeniershorst 209

NL-7328 TJ APELDOORN

Liability: Drenth Design & Consulting B.V.

Phone: +31643392605

E-Mail: ddc@yamorc.com

Directors: Karst Drenth

Trade register: 72184728

VAT No/Tax ID: NL-859019901B01